

3. [Lightweight Flexible Coupling (STYLE 10L)] >>>

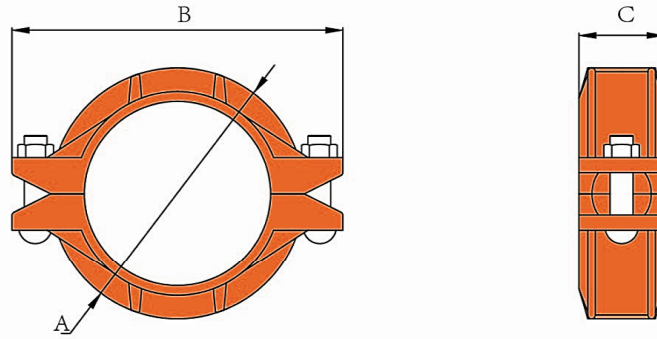

Pipe		Max Work press	Deflection from CL		Dimensions		
Size	O.D.				A	B	C
inch	mm	psi	degree	mm/m	in/mm	in/mm	in/mm
1 1/4"	42.2	300	4° -19'	75.3	2.64/67	4.09/104	1.78/45.2
1 1/2"	48.3	300	3° -46'	65.8	2.83/72	4.29/109	1.78/45.2
2"	60.3	300	3° -1'	52.5	3.31/84	4.65/118	1.84/46.7
2 1/2"	73	300	2° -30'	43.6	3.82/97	5.24/133	1.84/46.7
	76	300	2° -30'	43.6	3.82/97	5.35/136	1.84/46.7
3"	88.9	300	2° -3'	35.8	4.45/113	6.18/157	1.84/46.7
4"	114	300	2° -11'	38.1	5.75/146	7.56/192	2.05/52
6"	165.1	300	2° -10'	37.8	7.83/199	9.84/250	2.05/52
	168.3	300	2° -10'	37.8	7.91/201	10.2/259	2.05/52
8"	219	300	1° -40'	29.1	10.12/257	13.15/334	2.36/60

When low pressures are anticipated, or when weight consideration becomes significant. The style 10L is recommended. Pressures up to 175psi, depending on size. Special coatings or hot dip galvanizing are available as options.

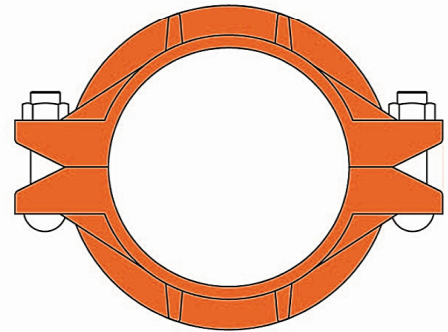

STYLE 10L



MATERIAL SPECIFICATIONS

HOUSING:

Ductile Iron conforming to ASTM A-536, Grade 65-45-12

ANSI BOLTS & HEAVY HEX NUTS:

Heat treated, oval-neck track head bolts conforming to ASTM A-183 Grade 2 with a minimum tensile strength of 110,000 psi and heavy hex nuts of carbon steel conforming to ASTM A-563 Grade A or Grade B, or SAEJ995 Grade 2. Bolts and nuts are provided zinc electroplated as standard.

METRIC BOLTS & HEAVY HEX NUTS:

Heat treated, zinc electroplated oval-neck track head bolts made of carbon steel with mechanical properties per ISO 898-1 Class 8.8. Hex nuts and bolts are zinc electroplated followed by a yellow chromate dip.

COATINGS:

- Rust inhibiting paint color: ORANGE(standard)
- Hot Dipped Zinc Galvanized(optional)
- Other available options: Example: RAL3000 Series For other coating requirements contact CPS representative.

Gasket:

- Pre Lube gasket
- Dri-seal gasket
- Standard EPDM

- EPDM: Temperature Range:-34°C~+110°C。
Color Mark: Green。 Suitable for hot water service within specified temperature range plus a variety of dilute acids ,oil free air and many chemical services. UL calssified for cold and hot(82°C)potable water service. Not recommended for hydrocarbon services.
- MVQ: Temperature Range:-70°C~+260°C。
Color Mark:Red。 For drinking water;hot water,oil free air, steam and petroleum.
- NBR: Temperature Range:-28.8°C~+82.2°C。
Color Mark:Orange。
Recommended for hydrocarbon products , air with oil vapors, vegetable oils and mineral oils within specified temperature range。 Not recommended for hot water services over 66°C or for dry air over 60°C.