

THIS SPACE FOR DESIGNER/ENGINEER APPROVAL

Job/Customer _____	Date _____	Contractor _____
Model Specified _____	Qty _____	Approved By _____
Designer/Engineer _____	Date _____	Contractor's PO# _____
Submitted by _____	Date _____	Other _____

5141 Series

**Full Port Forged Brass Uni-Flange Ball Valves
w/ Detachable Rotating Flange
& Multi-Function Hi-Flow Hose Drain
Adjustable Packing Gland, Nuts & Bolts
SWT x Rotating Flange
600 WOG - ISO 9001**



ITEM #	SIZE	CTN	CASE	A	B	C	D	E	F	G	H	I	J
51413	3/4"	2	20	3/4	3	2 1/4	2 1/2	7/16	1/2	1 1/2	2 11/16	4 1/8	2 3/4
51414	1"	2	20	1	3 1/4	2 5/8	2 1/2	7/16	1/2	1 1/2	2 11/16	4 1/8	2 3/4
51415	1 1/4"	2	20	1 1/4	3 1/2	2 7/8	3 3/16	7/16	1/2	1 1/2	2 11/16	4 1/8	3 1/4
51416	1 1/2"	2	10	1 1/2	4 3/8	3 3/8	3 13/16	7/16	1/2	1 1/2	2 11/16	4 1/8	3 1/2

HV MODELS FIT BOTH STANDARD & HIGH VELOCITY PUMPS

51413HV	3/4"	2	20	3/4	3	2 7/16	2 1/2	7/16	5/8	1 1/2	2 11/16	4 1/8	2 3/4
51414WV	1"	2	20	1	3 1/4	2 5/8	2 1/2	7/16	5/8	1 1/2	2 11/16	4 1/8	2 3/4
51415HV	1 1/4"	2	20	1 1/4	3 1/2	2 7/8	3 3/16	7/16	5/8	1 1/2	2 11/16	4 1/8	3 1/4
51416WV	1 1/2"	2	10	1 1/2	4 3/8	3 3/8	3 13/16	7/16	5/8	1 1/2	2 11/16	4 1/8	3 1/2
51417HV	2"	2	10	1 1/2	4 11/16	3 1/8	3 3/8	7/16	5/8	1 1/2	2 11/16	4 1/8	3 3/8

NOTE: 51417WHV is a Standard Port Valve



**PATENTED
TECHNOLOGY**

NO.	DESCRIPTION	MATERIAL
1	FLANGED BODY	BRASS
2	END CAP	BRASS
3	SEATS	PTFE
4	BALL	BRASS HCP
5	STEM	BRASS
6	STEM SEAL	PTFE
7	PACKING GLAND	BRASS
8	HANDLE	STEEL CP
9	HANDLE NUT	STAINLESS STEEL
10	HANDLE JACKET	VINYL
11	DRAIN VALVE SEATS	PTFE
12	DRAIN VALVE BALL	BRASS HCP
13	DRAIN VALVE STEM	BRASS
14	DRAIN VALVE STEM SEAL	PTFE
15	DRAIN VALVE HANDLE	ENAMEL COATED ALUMINUM
16	DRAIN VALVE HANDLE SCREW	BRASS
17	DRAIN VALVE CAP, WASHER & STRAP	BRASS W/ EPDM WASHER & STRAP
18	ROTATING FLANGE	BRASS
19	ROTATING FLANGE RING	STAINLESS STEEL
20	FLANGE BOLTS & NUTS	STEEL ZP

TEMP °F	PSI
100	600
150	485
200	395
250	210
300	N/A
350	N/A
366	N/A



Quality and Commitment Since 1954

www.webstonevalves.com • P: (800) 225-9529 • F: (800) 336-5133

Webstone product specifications in U.S. customary units are approximate and are provided for reference only. Webstone reserves the right to change or modify product design, construction, specifications or materials without prior notice and without incurring any obligation to make such changes and modifications on Webstone products previously or subsequently sold.

5141-5141Wspec_031913

THIS SPACE FOR DESIGNER/ENGINEER APPROVAL

Job/Customer _____	Date _____	Contractor _____
Model Specified _____	Qty _____	Approved By _____
Designer/Engineer _____	Date _____	Contractor's PO# _____
Submitted by _____	Date _____	Other _____

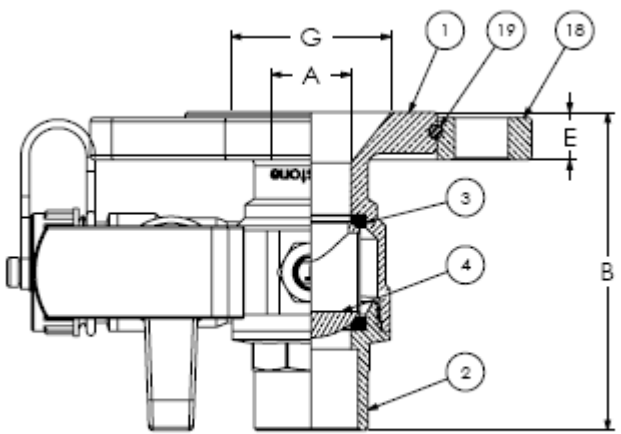
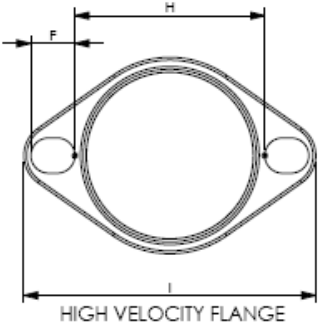
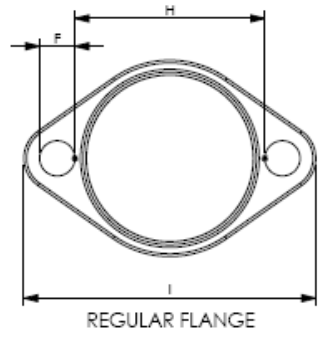
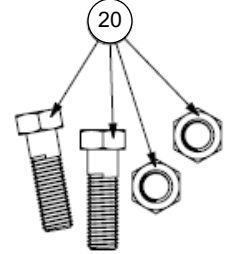
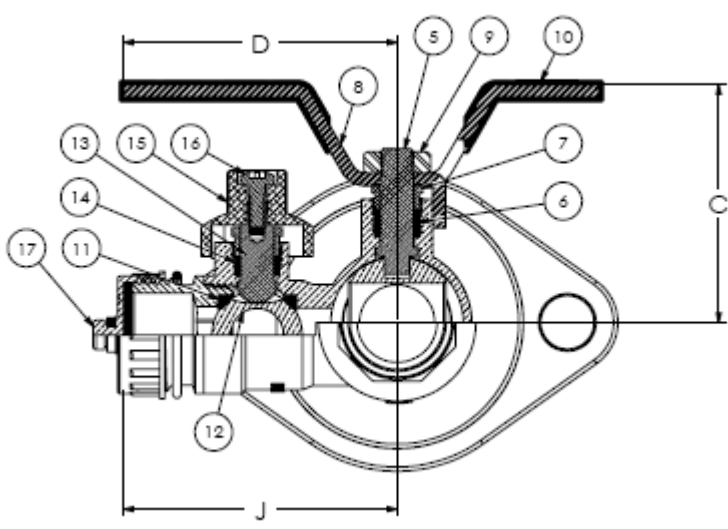

Specifications: Designed for residential, commercial or industrial use with water or a glycol mixture. This approved Webstone valve is actuated by a blowout proof stem and features an adjustable packing gland. Flange features a conical inlet to minimize turbulence. The rotating flange is secured by a snug-fit snap-ring that provides greater control over positioning during installation. Multi-directional main valve allows for draining from either side of the pump. Solder joint temperature ratings are per ASME B16.18 Annex A for 95-5 solder. Other solder materials have lower pressure/temperature limits. Do not silver braze or overheat valves when soldering.



Quality and Commitment Since 1954

www.webstonevalves.com • P: (800) 225-9529 • F: (800) 336-5133

Webstone product specifications in U.S. customary units are approximate and are provided for reference only. Webstone reserves the right to change or modify product design, construction, specifications or materials without prior notice and without incurring any obligation to make such changes and modifications on Webstone products previously or subsequently sold.

5141-5141Wspec_031913