

SPECIFICATIONS

Notes:

- 4" FPT inlet/outlet with 4" plain end adapters, single inlet and triple outlet.
- Unit weight - w/ composite cover: 93 lbs. (For wet weight add 542 lbs.)
- Maximum operating temperature: 150° F continuous
- Capacities - Liquid: 65 gal.;
Grease: 439.5 lbs. (60 gal.) @50GPM
Grease: 287.2 lbs. (43 gal.) @75GPM
Solids: 13 gal.
- For gravity drainage applications only.
- Do not use for pressure applications.
- Cover placement allows full access to tank for proper maintenance.
- Vent not required unless per local code.
- Engineered inlet and outlet diffusers with inspection ports are removable to inspect / clean piping.
- Integral air relief / Anti-siphon / Sampling access.
- Adjustable cover adapters provide up to 4" of additional height.
- Designed for below-grade, above-grade, indoor or outdoor installations.
- Safety Star®, access restrictor built into each cover adapter, prevents accidental entry to tanks (450 lb rating).

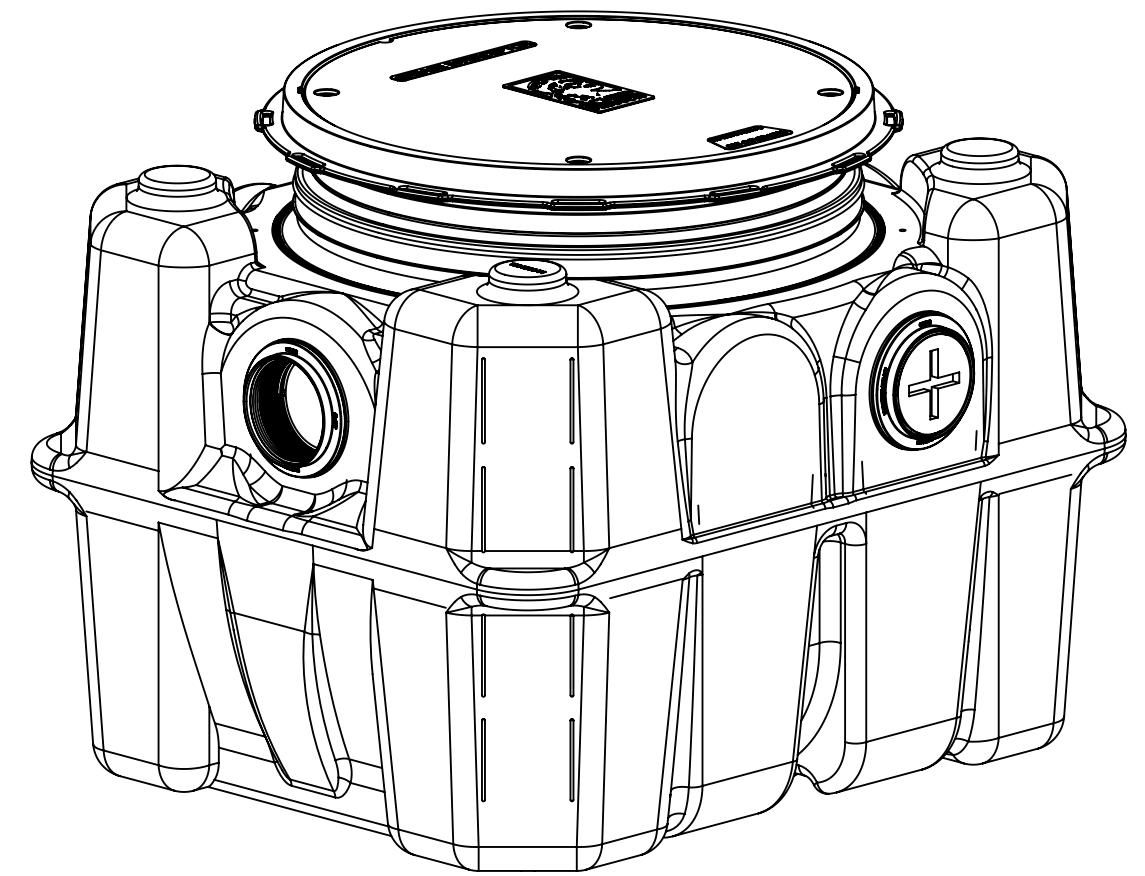
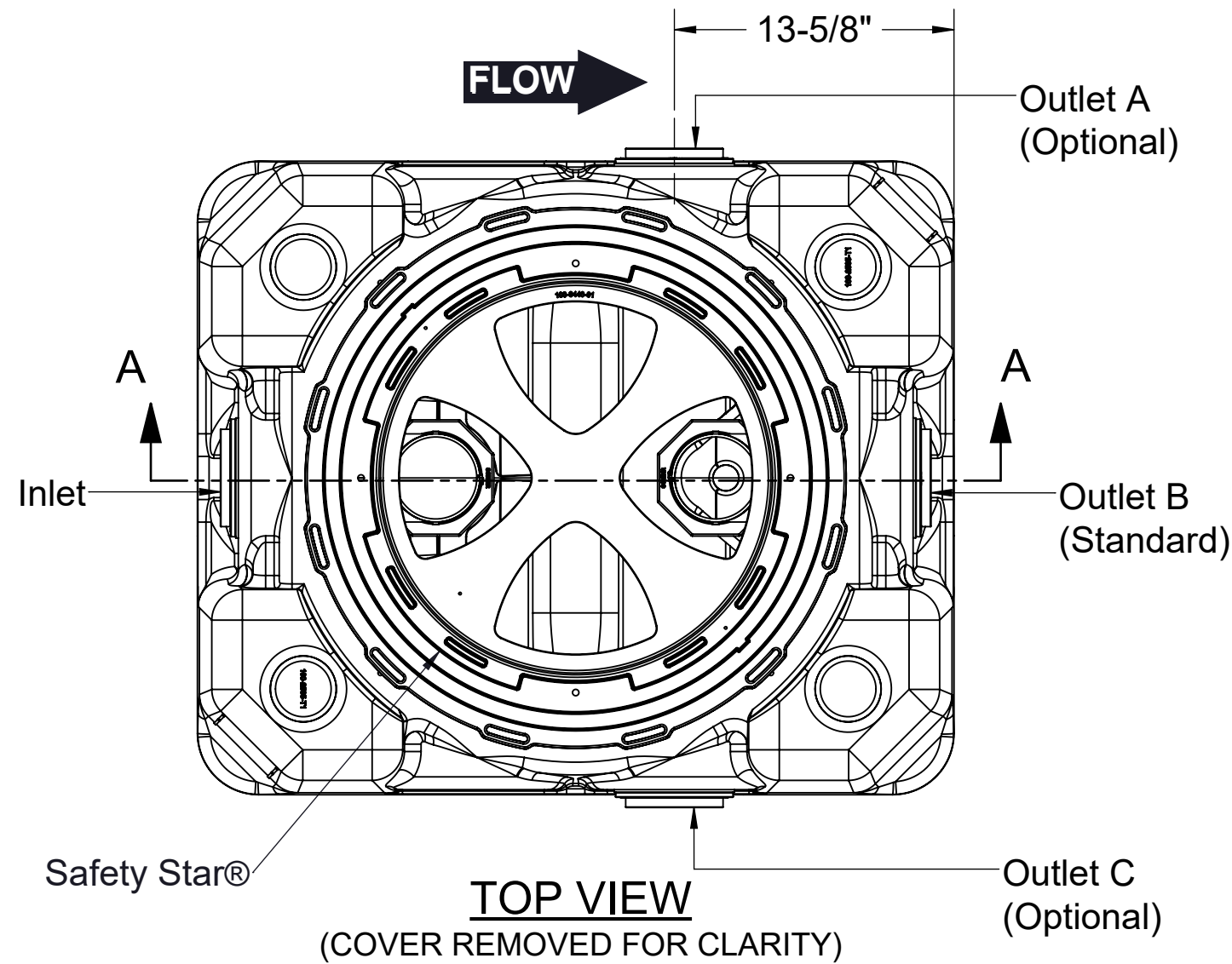

ISOMETRIC VIEW

ENGINEER SPECIFICATION GUIDE

Schier Great Basin™ grease interceptor model # GB-50 shall be lifetime guaranteed and made in USA of seamless, rotationally-molded polyethylene with minimum 3/8" uniform wall thickness. Interceptor shall be furnished for above or below-grade installation with adjustable cover adapter, Safety Star® access restrictor built into each cover adapter, and three outlet options. Interceptor shall be certified to ASME A112.14.3 (Type D) and CSA B481.1. Interceptor flow rate shall be 50 GPM or 75 GPM. Interceptor grease capacity shall be 439.5 lbs. Cover shall provide water/gas-tight seal and have minimum 2,000 lbs. load capacity.

CERTIFIED PERFORMANCE

Great Basin™ hydromechanical grease interceptors are third party performance-tested and listed by IAPMO to ASME #A112.14.3 and CSA B481.1 grease interceptor standards and greatly exceed requirements for grease separation and storage. They are compliant to the Uniform Plumbing Code and the International Plumbing Code.

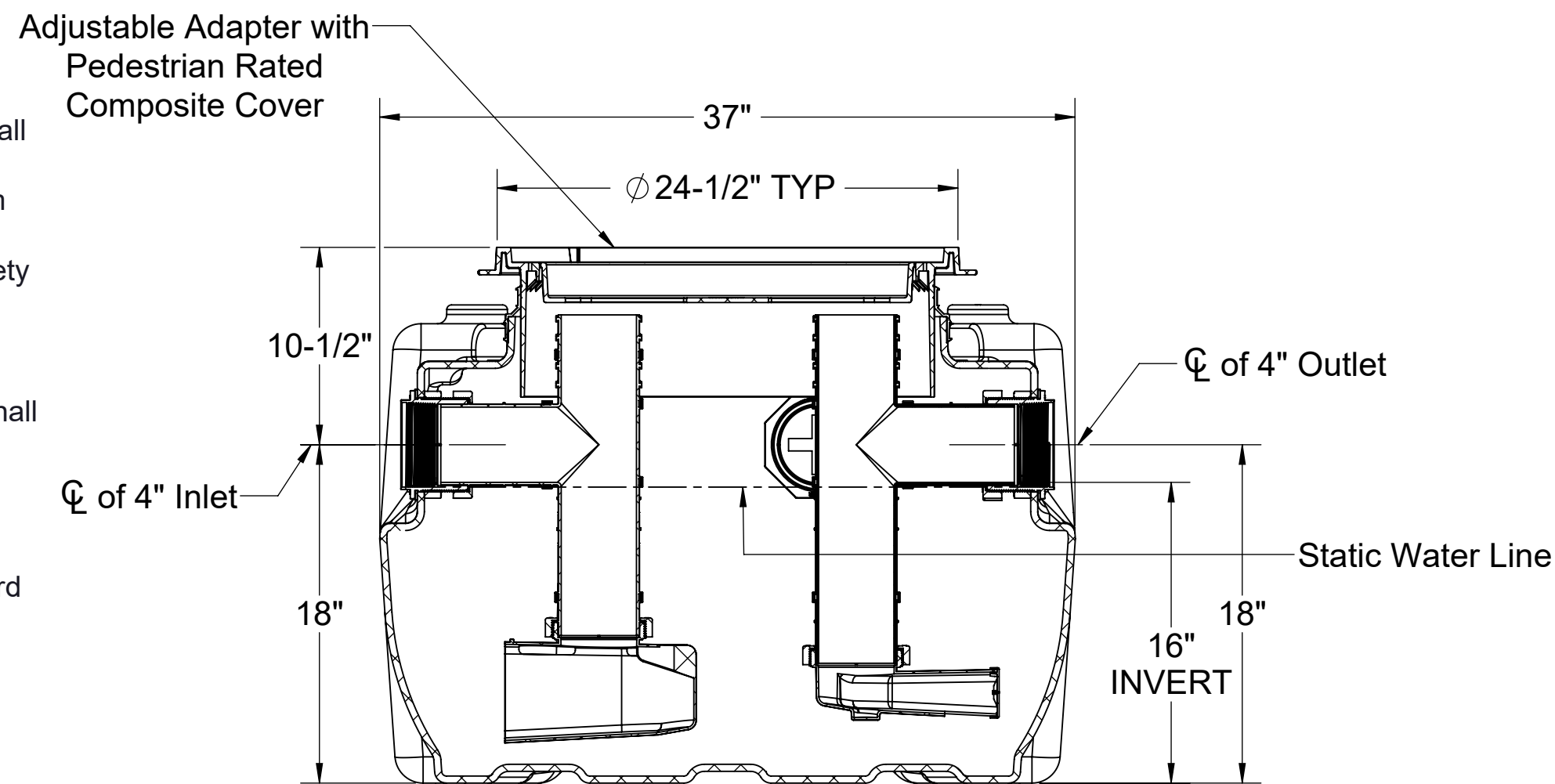

SECTION A-A

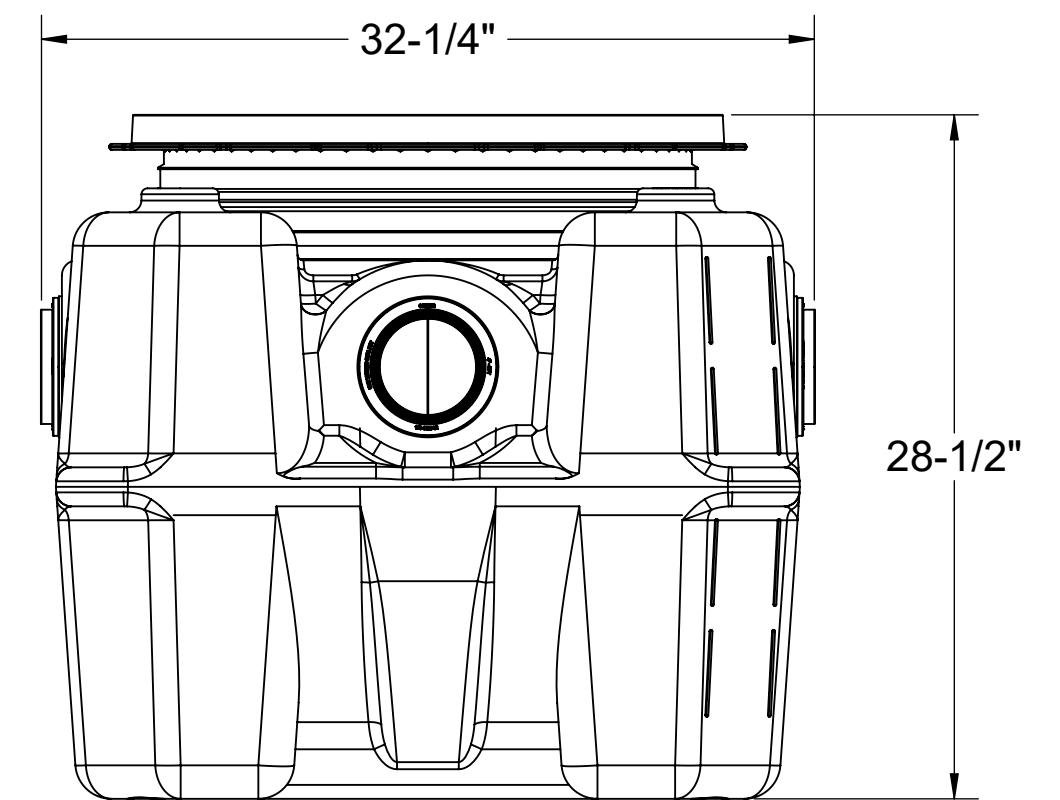

END VIEW

Type D certification does not require a flow control

SPECIFICATION SHEET

MODEL NUMBER:

GB-50

PART NUMBER: 4025-017-01

DESCRIPTION:

GB-50 GREASE INTERCEPTOR 50 GPM / 75 GPM, 4" INLET/OUTLET, PEDESTRIAN RATED COMPOSITE COVER

PROPRIETARY AND CONFIDENTIAL

THE INFORMATION CONTAINED IN THIS DRAWING IS THE SOLE PROPERTY OF SCHIER PRODUCTS. ANY REPRODUCTION IN PART OR AS A WHOLE WITHOUT THE WRITTEN PERMISSION OF SCHIER PRODUCTS IS PROHIBITED.

DWG BY: C.SINCLAIR

DATE: 4/12/2022

REV: A

ECO: BB - 12/5/22

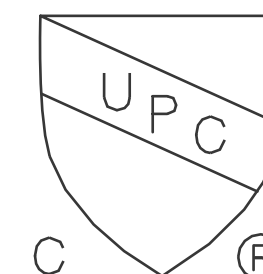
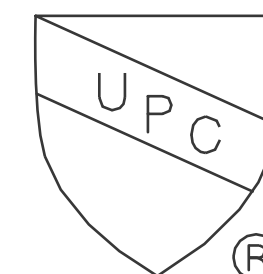

SCHIER

6455 Woodland Dr
Shawnee, KS 66218
Tel: 913-951-3300
Fax: 913-951-3399
schierproducts.com