



300 S. DAYTON ST.  
 DAVISON, MI 48423  
 PH: 810-653-9626  
 FAX: 810-654-2616

44UX-139

DESCRIPTION:

4 IN. XHCI HUB TO  
 1½ IN. SCH. 40 PL.

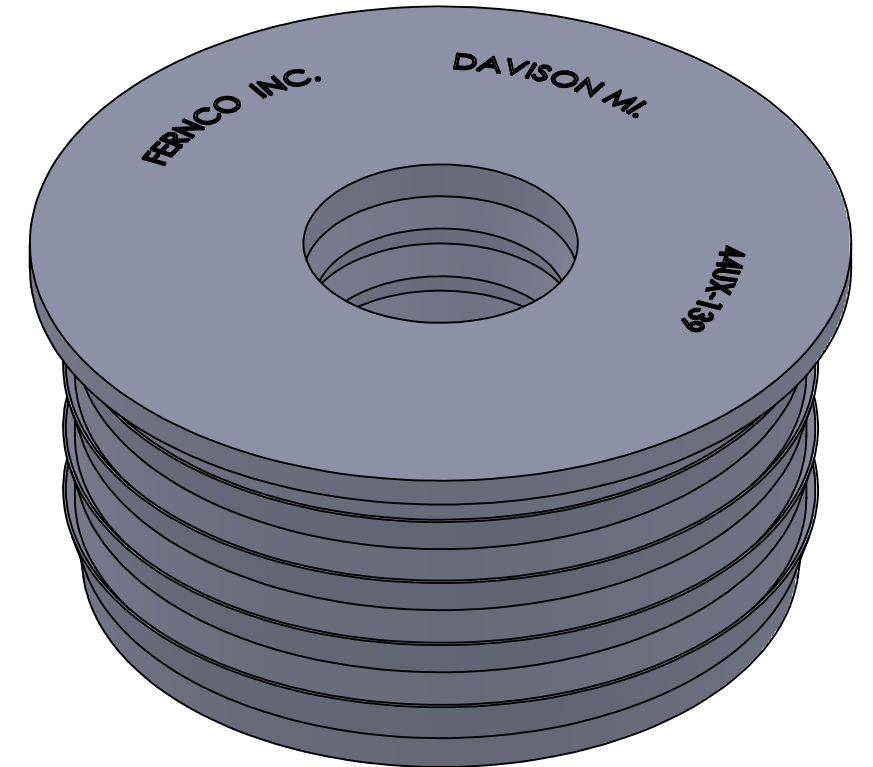
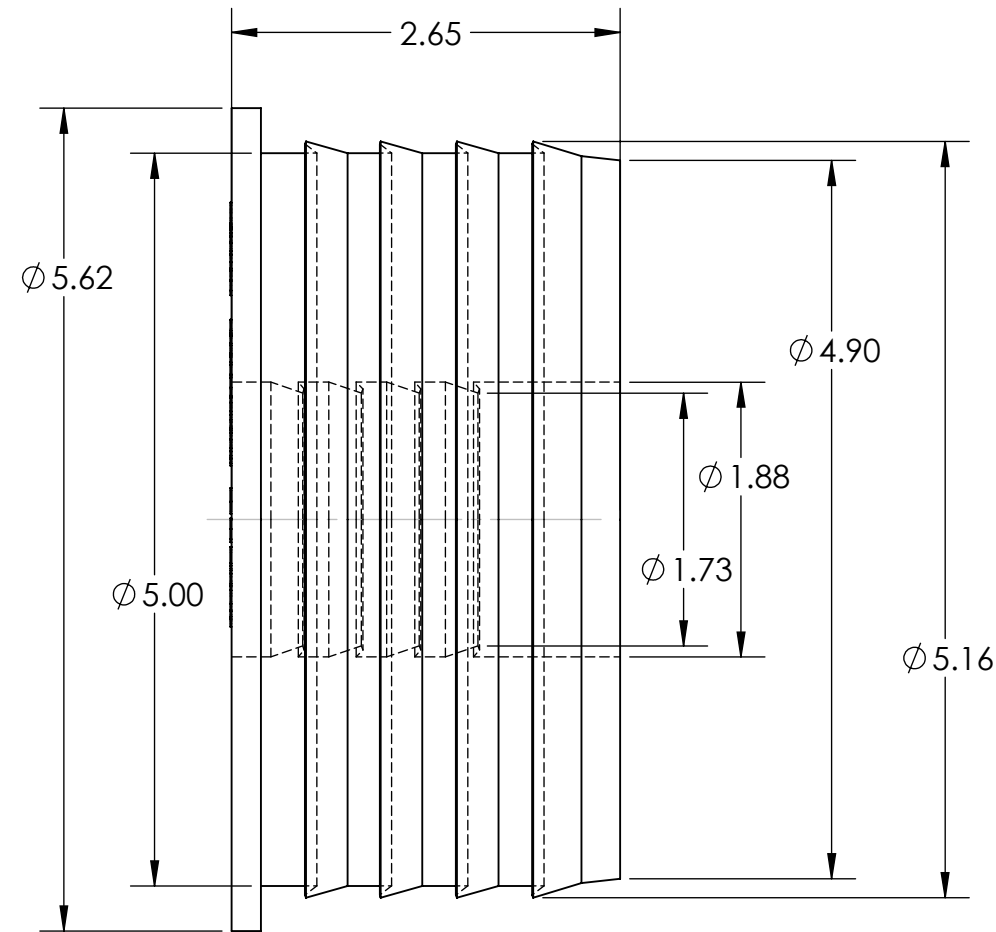
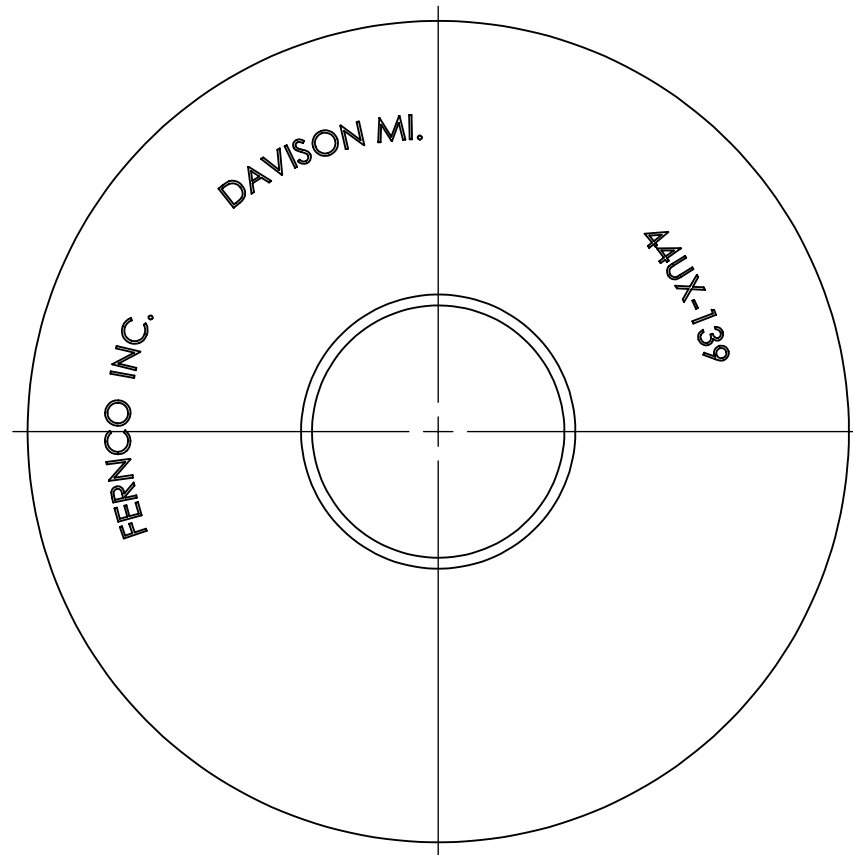

PROPRIETARY AND CONFIDENTIAL  
 THE INFORMATION CONTAINED IN THIS  
 DRAWING IS THE SOLE PROPERTY OF  
 FERNCO, INC. ANY REPRODUCTION IN  
 PART OR AS A WHOLE WITHOUT THE  
 WRITTEN PERMISSION OF FERNCO, INC.  
 IS PROHIBITED.

TOLERANCES:  
 Fractional ± 1/4"  
 .XX = ± .09  
 ANG. = ± 5°  
 UNLESS OTHERWISE SPECIFIED

|                        |                   |                         |                  |  |
|------------------------|-------------------|-------------------------|------------------|--|
| <i>Part Weight</i>     |                   |                         |                  |  |
| <i>Min/Max Temp.</i>   | -30/140 Degrees F | <i>Conforms to ASTM</i> | D5926            |  |
| <i>Pressure Tested</i> | 4.3 PSI           | <i>NOTE 1:</i>          | FOR DWV USE ONLY |  |
| <i>Material</i>        | FLEXIBLE PVC      |                         |                  |  |

|                                              |                   |                        |                        |
|----------------------------------------------|-------------------|------------------------|------------------------|
| UNITS:<br>INCHES                             | SIZE:<br><b>A</b> | DESIGNER:<br>T. OISTAD | SCALE:<br>not to scale |
| 3RD ANGLE PROJECTION<br>DO NOT SCALE DRAWING | CHECKER:          | DATE:<br>6/18/2020     | SHEET 1 OF 1           |