

Features

- Angle Pattern Boiler Drain-with Stuffing Box
- Brass Body
- 3/4" MHT Outlet
- Available in 1/2" & 3/4" MIP Inlet
- 1/2" inlet is dual MIP & Sweat

Specifications & Approvals

- CSA Approved - ASME A112.18.1/CSA B125.1
- NSF 61-9 certified
- 125 WOG / Maximum Temperature: 180°F
- Manufactured in ISO-9002 Facility

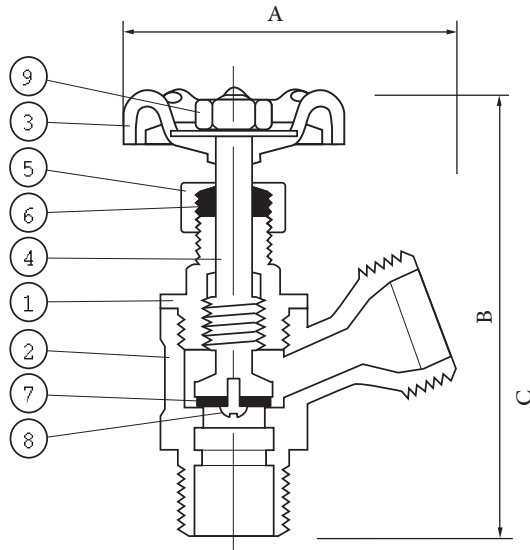

DIMENSIONS

Part#	Size	A	B	C
4612	1/2"	2.60	3.60	3.40
4634	3/4"	2.60	3.73	3.50

*For non-potable water use only

MATERIAL SPECIFICATIONS

#	Part Name	Material
1	Bonnet	Brass C85700
2	Body	Brass C85700
3	Handle	Cast Iron ASTM A48 CLASS 35
4	Stem	Brass C85700
5	Packing nut	Brass C36000
6	Gland Packing	NBR
7	Seat	EPDM Rubber
8	Seat screw	Brass C27000
9	Handle nut	Steel Plated AISI-1010

*Note: Information subject to change without notice.