

# Submittal Data

PROJECT:	UNIT TAG:	QUANTITY:
REPRESENTATIVE: _____	TYPE OF SERVICE:	DATE: _____
ENGINEER:	SUBMITTED BY:	DATE:
CONTRACTOR:	APPROVED BY:	DATE:
	ORDER NO.:	DATE:



## UPS 40-80/2 F

UPS is a three-speed circulator pump designed for heating and air-conditioning systems and is also used for central and district heating systems. The pump provides reliable and maintenance-free operation.

Note! Product picture may differ from actual product

Conditions of Service		Pump Data		Motor Data	
Liquid:	Water	Liquid temperature range:	14 .. 248 °F	Max. power input:	440 W
Temperature:	140 °F	Maximum ambient temperature:	104 °F	Rated voltage:	208-230 V
Specific Gravity:	0.985	Pipe connection:	GF 40/43	Mains frequency:	60 Hz
		Product number:	96402764	Enclosure class:	X4D
				Thermal protection:	EXT.

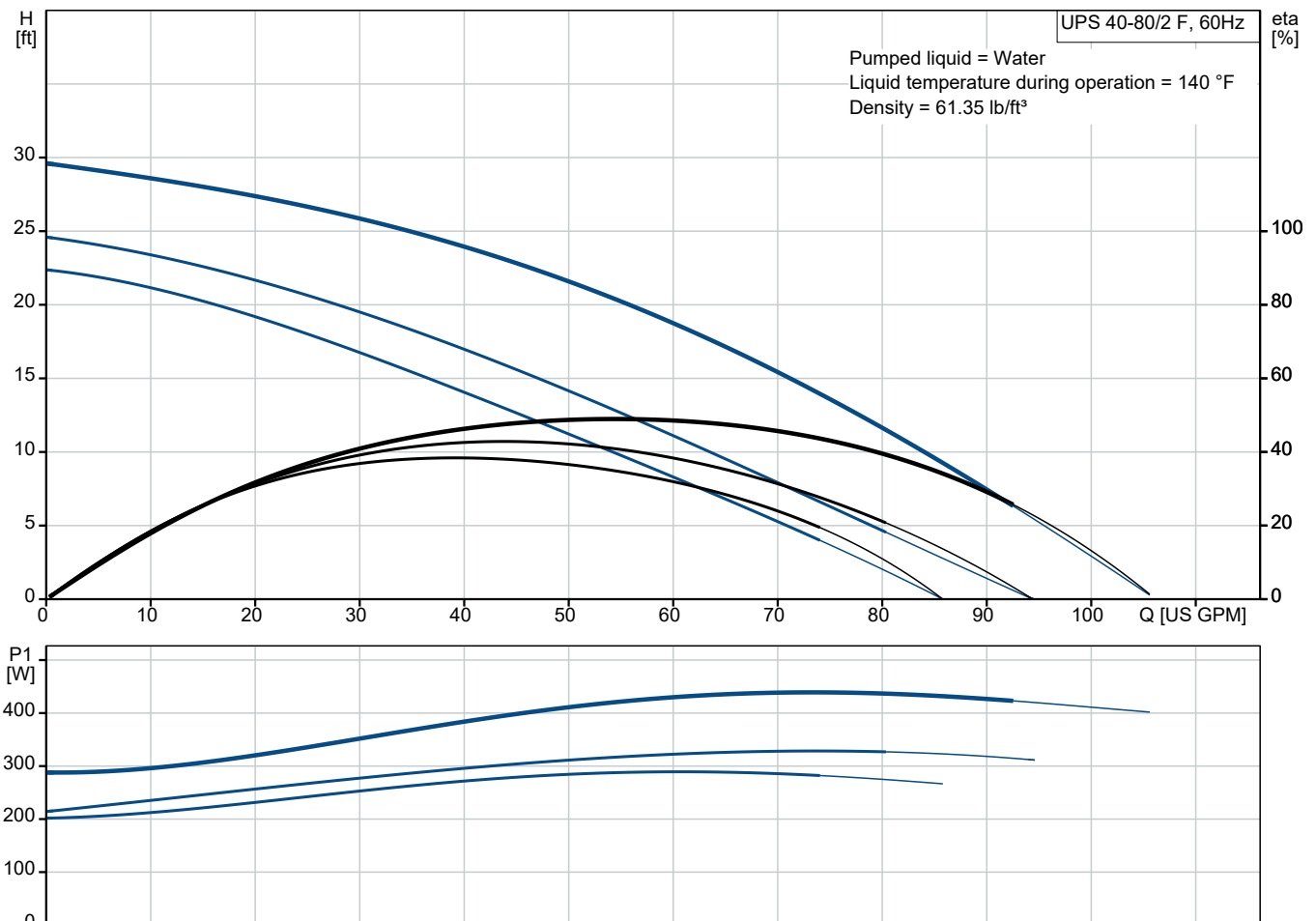

# Submittal Data

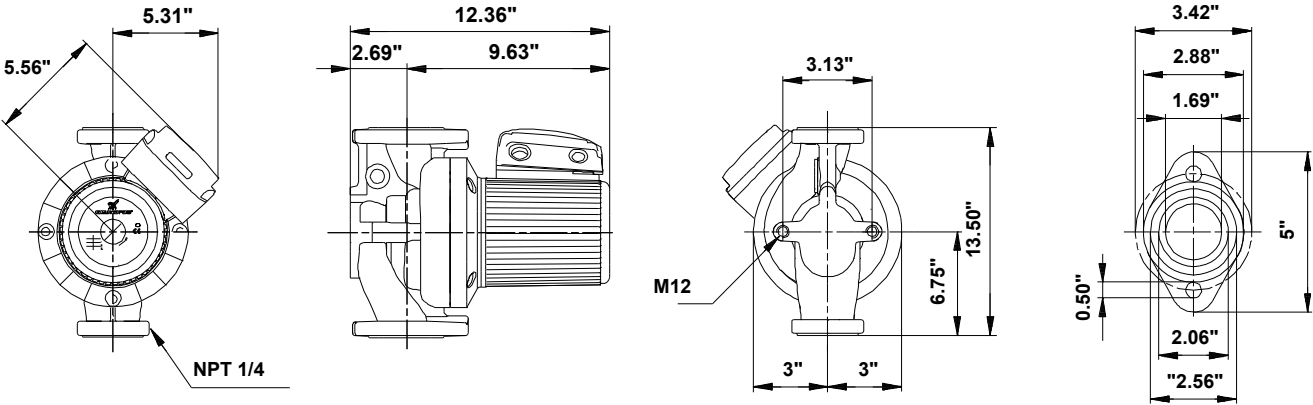

- Materials:**
- Pump housing: Cast iron
  - Pump housing: ASTM 35 B - 40 B
  - Impeller: Stainless steel
  - Impeller: AISI 304
  - Impeller: EN 1.4301

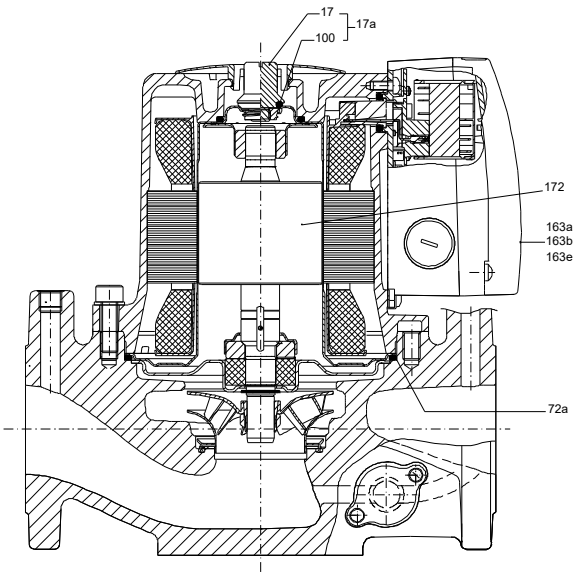

**Qty. Description**

1 UPS 40-80/2 F



Note! Product picture may differ from actual product

Product No.: [96402764](#)

The pump is of the canned rotor type, i.e. pump and motor form an integral unit without shaft seal and with only two gaskets for sealing. The bearings are lubricated by the pumped liquid.

In order to avoid problems in connection with disposal, great importance has been attached to using as few different materials as possible.

The pump is characterized by:

- \* 3 speed motor.
- \* Ceramic radial bearings.
- \* Carbon axial bearing.
- \* Stainless steel rotor can, bearing plate and rotor cladding.
- \* Aluminium alloy stator housing.
- \* Cast iron pump housing.
- \* Stator with built-in thermal switch.

The motor is a 3-phase motor.

The pump is supplied with a standard module in the terminal box.

The standard module is to be connected to the mains supply via external contactor.

Controls:

Relay: N

Liquid:

Pumped liquid: Water  
 Liquid temperature range: 14 .. 248 °F  
 Selected liquid temperature: 140 °F  
 Density: 61.35 lb/ft<sup>3</sup>

Technical:

Approvals: CCSAUS

Materials:

Pump housing: Cast iron  
 EN 1561 EN-GJL-250  
 ASTM 35 B - 40 B  
 Impeller: Stainless steel  
 EN 1.4301  
 AISI 304



Company name:

Created by:

Phone:

Date:

30/10/2024

**Qty. Description**

1 Installation:  
Range of ambient temperature: 32 .. 104 °F  
Maximum operating pressure: 145.04 psi  
Type of connection: DIN  
Pipe connection: GF 40/43  
Pressure rating for connection: PN 10  
Port-to-port length: 13 1/2 in  
  
Electrical data:  
Power input in speed 1: 0.3889 HP  
Power input in speed 2: 320 W  
Max. power input: 440 W  
Mains frequency: 60 Hz  
Rated voltage: 3 x 208-230 V  
Current in speed 1: 0.86 A  
Current in speed 2: 0.94 A  
Current in speed 3: 1.45 A  
Cos phi in speed 1: 0.85  
Cos phi in speed 2: 0.85  
Cos phi: 0.76  
Number of poles: 2  
Enclosure class (IEC 34-5): X4D  
Insulation class (IEC 85): F  
Built-in motor protection: CONTACT  
Winding resistance: 32.0 - 42.0 ohm  
  
Others:  
Terminal box position: 1.30H  
Net weight: 38.4 lb  
Gross weight: 45.9 lb  
Shipping volume: 2.08 ft<sup>3</sup>

Description	Value
<b>General information:</b>	
Product name:	UPS 40-80/2 F
Product No:	96402764
EAN number:	5700390680589
Price:	
<b>Technical:</b>	
Speed no:	3
Maximum head:	26.25 ft
Approvals:	CCSAUS
Model:	C
<b>Materials:</b>	
Pump housing:	Cast iron
Pump housing:	EN 1561 EN-GJL-250
Pump housing:	ASTM 35 B - 40 B
Impeller:	Stainless steel
Impeller:	EN 1.4301
Impeller:	AISI 304
<b>Installation:</b>	
Range of ambient temperature:	32 .. 104 °F
Maximum operating pressure:	145.04 psi
Type of connection:	DIN
Pipe connection:	GF 40/43
Pressure rating for connection:	PN 10
Port-to-port length:	13 1/2 in
Connect code:	F
<b>Liquid:</b>	
Pumped liquid:	Water
Liquid temperature range:	14 .. 248 °F
Selected liquid temperature:	140 °F
Density:	61.35 lb/ft <sup>3</sup>
<b>Electrical data:</b>	
Power input in speed 1:	0.3889 HP
Power input in speed 2:	320 W
Max. power input:	440 W
Mains frequency:	60 Hz
Rated voltage:	3 x 208-230 V
Current in speed 1:	0.86 A
Current in speed 2:	0.94 A
Current in speed 3:	1.45 A
Cos phi in speed 1:	0.85
Cos phi in speed 2:	0.85
Cos phi:	0.76
Number of poles:	2
Enclosure class (IEC 34-5):	X4D
Insulation class (IEC 85):	F
Built-in motor protection:	CONTACT
Thermal protec:	EXT.
Winding resistance:	32.0 - 42.0 ohm
<b>Controls:</b>	
Relay:	N
<b>Others:</b>	
Terminal box position:	1.30H
Net weight:	38.4 lb
Gross weight:	45.9 lb
Shipping volume:	2.08 ft <sup>3</sup>

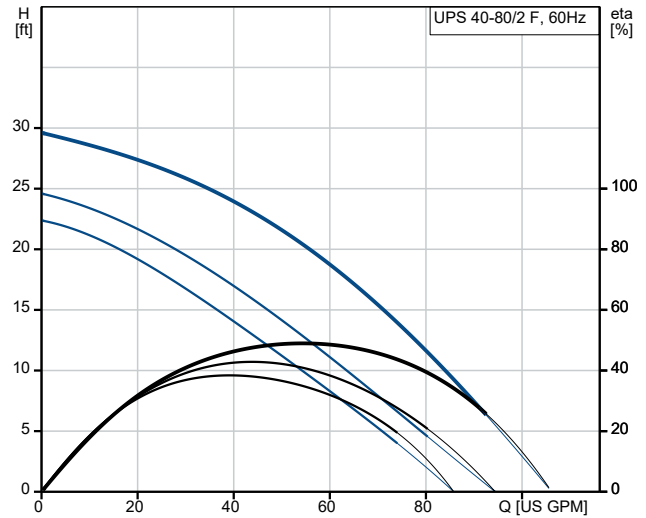

Pumped liquid = Water  
 Liquid temperature during operation = 140 °F  
 Density = 61.35 lb/ft<sup>3</sup>

