

# SUBMITTAL DATA SHEET



## Iron Body Gas Plug Valves with Lockwing -560G Series

FNPT x FNPT

SIZE	A	B	C	D	E	F	G	H
1/2	3.14	3.34	1.66	.59	1.60	1.62	1/2	1/2
1/2 X 3/4	3.14	3.34	1.66	.59	1.60	1.62	1/2	3/4
3/4	3.14	3.34	1.66	.59	1.60	1.62	3/4	3/4
3/4 X 1	3.36	3.67	1.86	.59	1.67	1.94	3/4	1
1	3.36	3.67	1.86	.59	1.67	1.94	1	1
1 1/4	3.88	4.69	2.37	.65	1.94	2.31	1 1/4	1 1/4
1 1/2	4.66	5.43	2.65	.62	2.31	2.62	1 1/2	1 1/2
2	5.60	5.82	2.96	.47	2.53	3.00	2	2

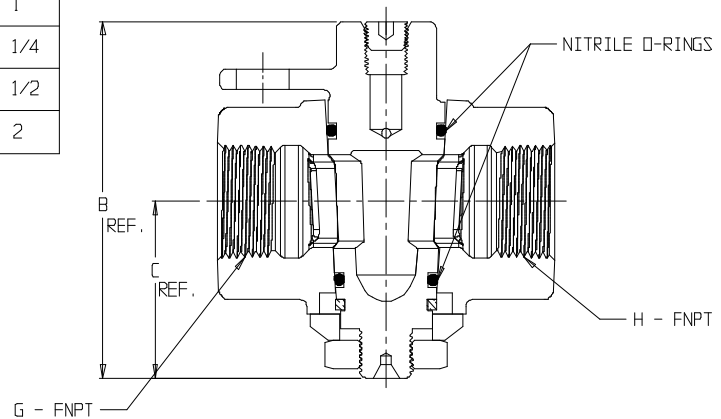
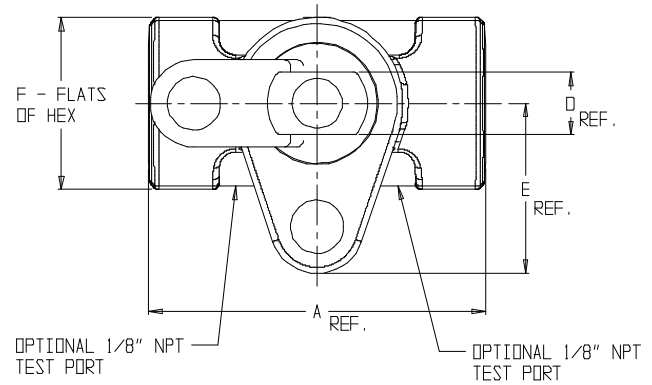

### SUBMITTAL INFORMATION

- Manufactured in compliance with ANSI/ASME B16.33 (latest revision)
- Brass castings conform to ASTM B584, UNS C83600 or C84400 (latest revision)
- Iron castings conform to ASTM A126 Class B Iron, with optional zinc coating per ASTM B633 with clear chromate coating and silicate sealer (latest revisions)
- Rated for 175 PSIG natural, manufactured, or LP gas pressure
- Valve can be re-lubricated while in service and under pressure
- Plug rotates 360°
- Tamper-resistant design prevents disassembly with normal household tools
- Port opening sized to accommodate the best known stop changers
- Lockwing design accommodates standard barrel locks



**A.Y. McDonald Mfg. Co.**  
P.O. Box 508  
Dubuque, IA 52004-508

**Toll Free:** 1-800-292-2737  
**Fax:** 1-800-832-9296  
**Hours:** 7:00 a.m. – 5:00 p.m., CST

sales@aymcdonald.com  
[www.aymcdonald.com](http://www.aymcdonald.com)

A.Y. McDonald considers the information on this assembly drawing correct when published. Item and option availability, including specifications, are subject to change without notice.

**Submitted by:**

08-11