

data sheet

# 70-100/200 HC series

bronze ball valve with 3/4" hose connection and protective cap & chain



### description

The "Apollo"® 70-HC series models are ideally suited for direct connection to hoses. Valves feature a heavy duty machined hose thread cover with heavy duty stainless steel chain to prevent loss. Standard lever and nut are stainless steel.

### size range

- 1/2" - 1"

### connections

- threaded
- solder joint

### configurations

- 70-100 series - threaded
- 70LF-100-200HC - lead-free
- 70-200 series - solder joint

### approvals

- MSS SP-110
- CSA B51 CRN: OC10908.5C
- ANSI/ASME B1.20.7 hose thread
- Buy American Act (BAA)
- Build America Buy America (BABA) Act



*this specification is provided for reference only. we reserve the right to change any portion of this specification without notice and without incurring obligation to make such changes to Aalberts integrated piping systems products previously or subsequently sold.*

### Aalberts integrated piping systems

10715 Sikes Place / suite 200 / Charlotte / NC / 28277  
[aalberts-ips.us](http://aalberts-ips.us)

### features

- NPT or solder end x 3/4"-11.5 NH
- full pressure rated heavy brass hose cap
- blowout-proof stem design
- adjustable packing gland
- premium RPTFE seats and stem packing
- stainless steel lever and stem nut
- heavy duty stainless steel ball chain
- 100% factory tested
- made in USA

component	material
body	bronze, ASTM B584-C84400
retainer	brass, ASTM B16
ball	brass ASTM B16, C36000 chrome plated brass B283, C37700 chrome plated, or stainless steel, A276-316
seat (2)	RPTFE
stem	brass, ASTM B16, C36000
gland nut	brass, ASTM B16, C36000
stem packing	MPTFE
lever and grip	stainless steel w/ vinyl
lever nut	stainless steel
ball chain	stainless steel
stem bearing	RPTFE

### performance rating

CWP	temperature	vacuum service
600 psig (maximum pressure)	200°F (maximum temperature)	29 in. Hg

\*70-2xxHC intended for soft solder installation using solders with melting temperature of < 500°F.

job name	
job location	
engineer	
contractor	
tag	
PO#	
rep	
wholesaler dist	

data sheet

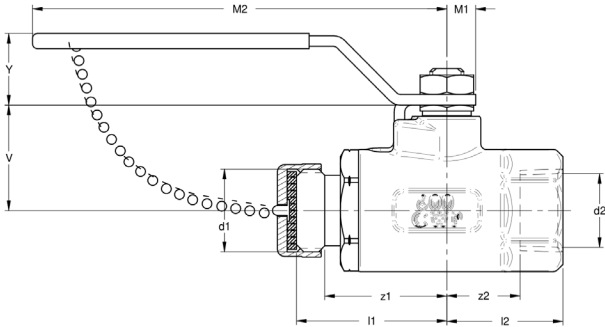

dimensions

NPT

part number	size	bore size	d1	d2	l1	l2	z1	z2	M1	M2	V	Y	weight	Cv
70-103-HC	½"	0.50"	1.06"	0.84"	1.65"	1.09"	1.29"	0.56"	0.55"	3.85"	1.06"	2.78"	0.63 lbs	15
70-104-HC	¾"	0.68"	1.06"	1.05"	1.93"	1.49"	1.57"	0.94"	0.67"	4.76"	1.40"	2.78"	1.30 lbs	30
70-105-HC	1"	0.68"	1.06"	1.32"	2.24"	1.67"	1.82"	0.99"	0.67"	4.76"	1.51"	2.78"	1.72 lbs	43

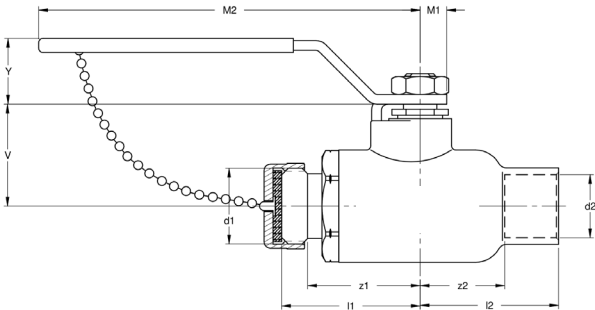

solder

part number	size	bore size	d1	d2	L1	L2	z1	z2	M1	M2	V	Y	weight	Cv
70-203-HC	½"	0.50"	1.06"	0.63"	1.65"	1.42"	1.29"	0.92"	0.55"	3.85"	1.06"	2.73"	0.71 lbs	15
70-204-HC	¾"	0.68"	1.06"	0.88"	1.93"	1.93"	1.57"	1.18"	0.67"	4.76"	0.87"	2.78"	1.44 lbs	30
70-205-HC	1"	0.68"	1.06"	1.32"	2.24"	2.24"	1.82"	0.99"	0.67"	4.76"	0.87"	2.78"	1.95 lbs	43

options

option	component	size
(-04)	2 ¼" cs stem extension	½" - 1"
(-07)	steel tee handle	½" - 1"
(-11)	Therma-Seal™ insulating tee handle	½" - 1"
(-15)	wheel handle, steel	½" - 1"
(-27)	ss latch-lock lever & nut	½" - 1"
(-94)	2 ¼" stem extension & balancing stop	½" - 1"
	70LF-140 & 70LF-240 series with ss ball & stem	½" - 1"