

Series CV

COMBINATION VALVES



FEATURES AND BENEFITS

- Combines three valves in one: shut-off valve, balancing valve, and check valve.
- Provides the feature of changing the flange orientation to allow 90° pipe connection.
- Reduces the overall system pressure drop since fewer individual components are needed when installing a pump.
- Simplifies dismantling and servicing. Internal parts, such as the disc, can be easily removed and/or replaced.
- Contains a built-in bypass valve allowing for drainage of water upstream of the check valve. (The bypass valve **MUST BE CLOSED** at all times in normal operation and should **ONLY** be used by authorized personnel to drain water from the piping above.)

TECHNICAL DATA

	ANSI 125	ANSI 250
Pumped liquid	Water	Water
Max. pressure	175 psi	250 psi
Max. liquid temperature	150 °F	248 °F
Test pressure	265 psi	426 psi

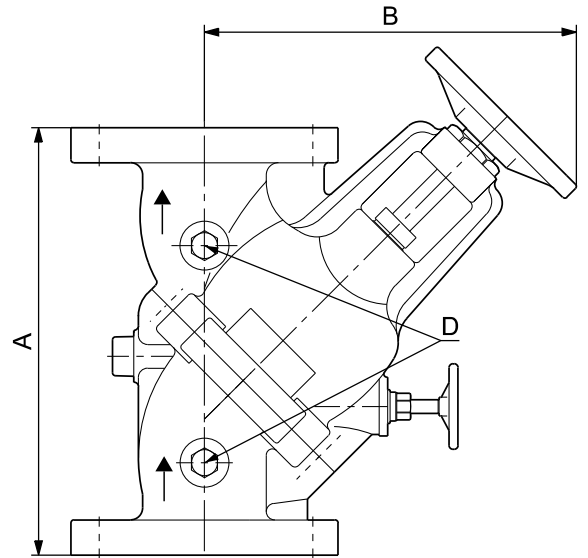

125 PSIG ANSI

Part No.	Inlet/Outlet (inches)	Dimensions (Inches)			Wgt. (lbs)
		A	B	D-NPT	
97523122	2 x 2	9.37	7.91	3/8	25
97523123	2.5 x 2.5	11.02	8.62	1/2	34
96877844	3 x 3	11.65	9.61	1/2	40
96877845	4 x 4	13.27	10.83	1/2	56
97523124	5 x 5	14.23	11.89	1/2	75
96877846	6 x 6	17.28	14.45	1/2	120
96877847	8 x 8	20.24	16.69	1/2	194
97583125	10 x 10	25.04	21.54	1/2	422
97523126	12 x 12	27.44	23.35	1/2	635
97523127	14 x 14	29.80	27.68	1/2	696

250 PSIG ANSI

Part No.	Inlet/Outlet (inches)	Dimensions (Inches)			Wgt. (lbs)
		A	B	D-NPT	
97523122	2 x 2	9.37	7.91	3/8	25
97523123	2.5 x 2.5	11.02	8.82	1/2	34
96877844	3 x 3	11.65	9.61	1/2	40
96877845	4 x 4	13.27	10.83	1/2	56
97523124	5 x 5	14.53	11.89	1/2	75
96877846	6 x 6	17.28	14.45	1/2	120
96877847	8 x 8	20.24	16.69	1/2	194
97583125	10 x 10	26.42	21.54	1/2	422
97523126	12 x 12	28.94	23.35	1/2	635
97523127	14 x 14	31.30	27.68	1/2	696

GRUNDFOS TECHNICAL INSTITUTE

The Grundfos Technical Institute (GTI) offers busy professionals the opportunity to maintain their continuing education credits through a wide variety of flexible learning avenues.

Visit www.grundfos.us/training, to choose from a number of education possibilities that suit your needs and schedule, including face-to-face classes, group webinars and self-directed online courses.

GRUNDFOS COMMERCIAL BUILDING SYSTEMS

Grundfos is a leading supplier of full-range pump solutions from water supply to wastewater discharge and every application in between.

At Grundfos, we think beyond the pump. Our goal is to understand the building as a whole in order to develop solutions built with intelligence and adaptability.

This approach has made us a preferred partner for contractors, consulting engineers and building owners as they look to build the most sustainable and efficient commercial buildings in the world.