

RIGID COUPLING STYLE 5

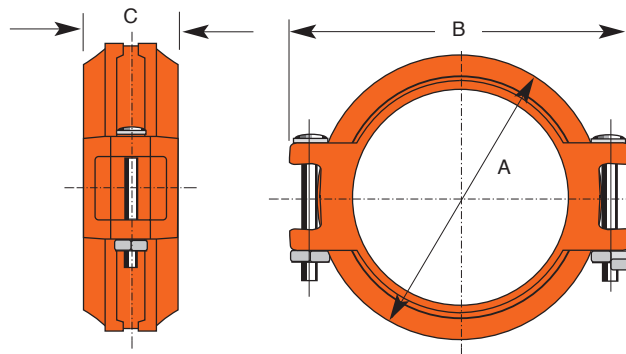

UL Listed
Under File No. EX15592

- Provides joint rigidity, for the support and hanging requirements of ANSI B31.1
- Tongue and groove arrangements in housings do not permit expansion, contraction or deflection
- Available with hot dipped galvanized coating as optional
- Supplied with pre-lubed gasket
- Provided with EPDM Gasket suitable -40 to 230°F



Pipe		Max. Working Pressure (psi)*	Allow Pipe End Separation (In.)	Dimensions (In.)			Approx. Weight Each (lb.)
Nominal Size (In.)	Actual Size (In.)			A	B	C	
1	1.315	300	0.1	2.36	4.02	1.77	1.2
1-1/4	1.66	300	0.1	2.75	4.17	1.732	1.31
1-1/2	1.9	300	0.1	2.87	4.25	1.732	1.26
2	2.375	300	0.1	3.43	4.84	1.732	1.47
2-1/2	2.875	300	0.1	4.06	5.43	1.772	1.76
3	3.5	300	0.1	4.61	6.54	1.772	2.41
4	4.5	300	0.16	5.47	7.48	1.929	2.93
5	5.563	300	0.16	6.62	8.58	1.929	3.55
6	6.625	300	0.16	7.60	9.80	1.97	4.73
8	8.625	300	0.19	9.96	12.60	2.323	8.15
10	10.75	300	0.19	13.20	16.80	2.677	17.08
12	12.75	300	.20	14.96	18.50	2.56	24.5

NOTES: Allowable pipe end separation is for cut groove pipe, for roll groove, figures will be one-half of the values listed at time of initial pressurization.
 ■ – Bolts and Nuts are galvanized. * – Maximum pressure including surges and maximum end loads from all internal and external forces, to which a joint could be subject under normal working conditions. This rating provides a nominal safety factor of 1.5 times working pressure based on standard weight steel pipe. Maximum working pressure may be subjected to a one time field test of 1.5 times the figures indicated. Refer to installations and groove specifications when assembling any grooved product. EPDM gasket is supplied as standard. For other gaskets contact us.

PROJECT	APPROVAL STAMP
PROJECT:	<input type="checkbox"/> APPROVED
ADDRESS:	<input type="checkbox"/> APPROVED AS NOTED
ENGINEER:	<input type="checkbox"/> NOT APPROVED
SUBMITTAL DATA:	REMARKS:
NOTES 1:	
NOTES 2:	