

HRYA - HD Clevis Roller Hangers

Designed for Suspending Pipe with Vertical Adjustment

- Maximum temperature 450°F
- Complies with Federal Specification A-A-1192A Type 43, WW-H-171-E Type 44, ANSI/MSS SP-69 and MSS SP-58 Type 43
- Non conductive, corrosion resistant Pipe Rollers for protection against severe weather conditions and moderate corrosive conditions such as marine atmospheres.

Sizes: 2" - 16"

Material: Steel

Finish: Hot Dipped Galvanized

Approvals: Complies with ANSI/MSS SP-69 MSS SP-58 Type 44, A-A-1192A Type 44, WW-H-171-E Type45

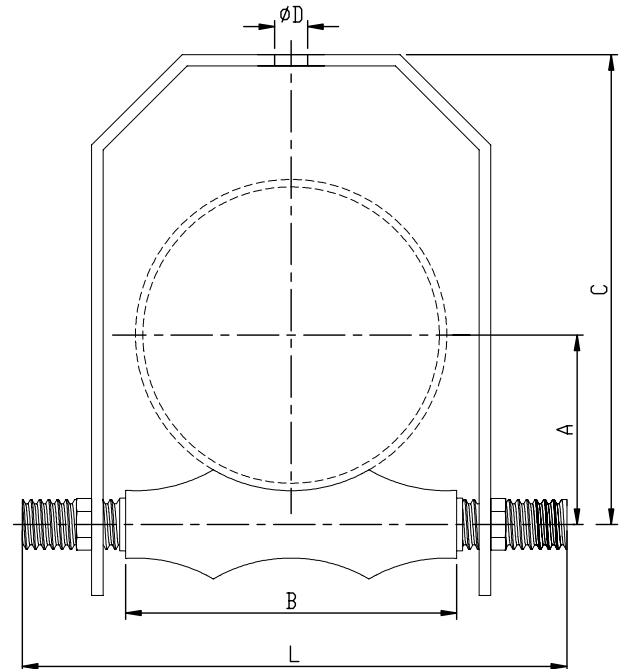

ITEM	SIZE INCHES	MAX LOAD (LBS)	A	B	C	D	L	EA WEIGHT
HRSP-HD02	2"	150	1-5/8"	2-7/8"	4-3/8"	7/16"	4"	0.98
HRSP-HD03	3"	310	2-1/4"	3-3/4"	6-3/8"	9/16"	5"	1.61
HRSP-HD04	4"	475	2-3/4"	4-3/4"	7-1/2"	11/16"	6"	2.61
HRSP-HD05	5"	685	3-1/2"	5-3/4"	8-5/8"	13/16"	8"	4.42
HRSP-HD06	6"	780	4"	6-7/8"	10-1/4"	13/16"	9"	5.86
HRSP-HD08	8"	780	5-1/8"	8-7/8"	12-3/4"	13/16"	12"	12.08
HRSP-HD10	10"	965	6-3/8"	11"	15"	15/16"	14-1/2"	18.34
HRSP-HD12	12"	1,200	7-1/2"	12-1/2"	17-3/8"	15/16"	16-1/2"	25.3
HRSP-HD14	14"	1,200	8-3/8"	14-3/8"	18-7/8"	1-1/16"	18"	36.01
HRSP-HD16	16"	1,200	9-1/2"	16-3/8"	20-3/4"	1-1/16"	20-1/2"	43.68

Engineer's Approval			
Job Name / # _____	Contractor _____	Date _____	
Job Location _____	Engineer _____	Date _____	