



A CSW Industrials Company

PRODUCT DATA SHEET

SURESEAL®

The Original Waterless Inline Drain Trap Seal

Description

SureSeal® waterless inline drain trap seal solves odor and bug problems associated with infrequently used floor drains. The seal is installed into the outlet of drain bodies or drain hubs to protect the trap seal from evaporation, creating a physical barrier that blocks sewer gases and their odors from escaping. SureSeal provides waterless trap seal protection equivalent to water-based trap primers. Its patented memory hinge and pressure relief valve deliver superior, longer-lasting operation. SureSeal can be easily retrofitted to older drains, as its various designs ensure compatibility with all other drain types.



Applications

For 2", 3", 3 1/2", and 4" floor drains and strainers, easily retrofitting older drains to trap odors effectively. Recommended for shower, outdoor, basement, HVAC, water heater, and maintenance area floor drains, as well as residential and multi-unit bathrooms and kitchens.

Characteristics | Features

- Saves water—eliminates the need for trap primer
- Stops drain odors and bugs
- Simple one-piece installation
- Four press-fit models for 2", 3", 3 1/2", and 4" that fit both cast iron or plastic floor drains
- SureSeal® patented pressure relief valve prevents air lock
- Patented memory hinge ensures a complete seal every time

Packaging

Code	Size	Qty. per Case	Lbs. per Case	Cubic Ft per Case
97041	2" Drain Trap Seal	6	1.69	0.39
97042	3" Drain Trap Seal	6	1.95	0.39
97043	3-1/2" Drain Trap Seal	6	2.59	0.53
97044	4" Drain Trap Seal	6	2.40	0.38
97081	2" Drain Trap Seal (Contractor Pack)	24	8.50	0.12
97082	3" Drain Trap Seal (Contractor Pack)	24	8.40	0.29
97084	4" Drain Trap Seal (Contractor Pack)	24	9.60	0.38



Patent No. 9,010,383
 State of Massachusetts approved
 State of Wisconsin approved

Installation Instructions 4" and 3½"

1. Using your thumb and forefinger, grasp the SureSeal by the exterior gasket at the points marked by three lines and apply pressure so that the fins collapse towards you and the SureSeal can pass through the strainer throat. (Once the SureSeal has passed through the strainer throat, it will return to its original shape).
2. Insert the SureSeal into the outlet of the floor drain body at least 4.5" to 5.5" below the drain grate, ensuring the SureSeal is level and properly seated.
3. Replace the grate on the floor drain.

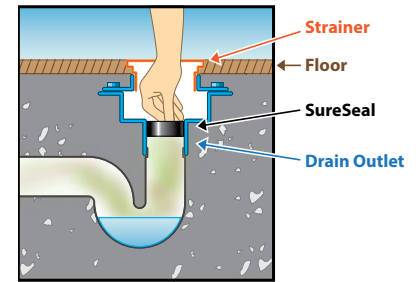

Installation Instructions 3" and 2"

1. Remove the grate on the floor drain.
2. Press fit the SureSeal into the drain body.
3. Replace grate on floor drain.

Additional information available at www.rectorseal.com.

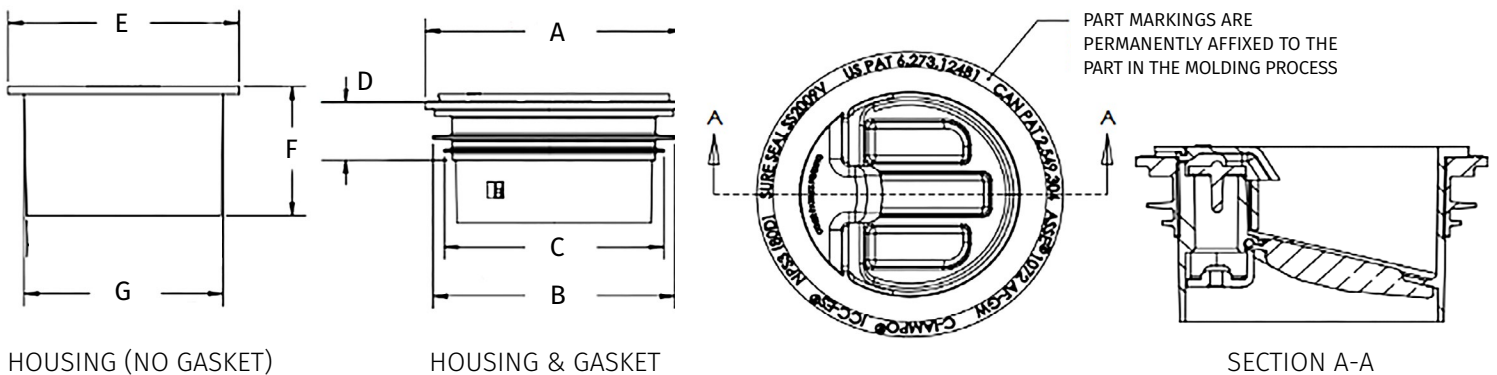

Model	A	B	C	D	E	F	G
2" Drain Trap Seal	2.35"	2.20"	2.00"	0.59"	2.10"	1.30"	1.81"
3" Drain Trap Seal	3.23"	2.90"	2.76"	0.75"	2.92"	1.52"	2.75"
3½" Drain Trap Seal	3.75"	3.55"	X	0.85"	3.14"	1.60"	2.75"
4" Drain Trap Seal	4.34"	4.13"	4.08"	1.20"	X	1.14"	3.21"

Limited Warranty



For more information on our product limited warranty, visit RectorSeal.com

Manufactured by

RectorSeal, LLC

2601 Spenwick Drive • Houston, TX 77055, USA • 800-231-3345 • Fax 800-441-0051 • rectorseal.com

3255 Wyandotte St. East Windsor, ON N8Y 1E9, Canada • 519-966-4901

A CSW Industrials Company. RectorSeal, the logos and other trademarks are property of RectorSeal, LLC, its affiliates or its licensors and are protected by copyright, trademark and other intellectual property laws, and may not be used without permission. RectorSeal reserves the right to change specifications without prior notice. ©2024 RectorSeal. All rights reserved. R51079-1124