

Model PRV-1A Pressure Reducing Valve Pilot Operated

IMPORTANT

Refer to Technical Data Sheet TFP2300 for warnings pertaining to regulatory and health information.

Scan the QR code or enter the URL in a web browser to access the most up-to-date electronic version of this document. Data rates may apply.



docs.jci.com/tycofire/TFP1581

General Description

The TYCO Model PRV-1A Pressure Reducing Valves, 2 in. to 8 in. (DN50 to DN200), are factory-assembled and fully trimmed valve arrangements for pressure control. They are used on water filled pipes, where it is necessary to reduce a higher inlet pressure to a lower delivery pressure under static and/or residual flowing conditions.

The valve design uses the DV-5A valve body incorporating the simple diaphragm design, and are available in flange-by-flange and grooved-by-grooved connections.

The Model PRV-1A Valve is intended to automatically maintain the outlet "set pressure" (static and residual) within a close range, regardless of fluctuations in the higher pressure inlet line or varying flow rates.

The Model PRV-1A Valve is provided with a factory outlet "set pressure" of approximately 125 psi (8,6 bar); however, it may be field set to a nominal outlet "set pressure" of 90 to 175 psi (6,2 to 12,1 bar).

Typical applications

- Within the main header, as shown in Figure 1, supplying wet pipe, dry pipe, deluge, or preaction system risers, and/or a standpipe system supplying hose connections
- As part of a sectional floor control assembly, as shown in Figure 2, supplying sprinkler systems, and/or hose stations

Features

- Eliminates any required bleeding of trapped air from the diaphragm chamber during installation
- Accurate pressure control
- Epoxy coated internal and external
- One piece, one moving part diaphragm
- In-line service
- One pilot valve sub-assembly provides for any outlet "set pressure", that is, 90 to 175 psi (6,2 to 12,1 bar)

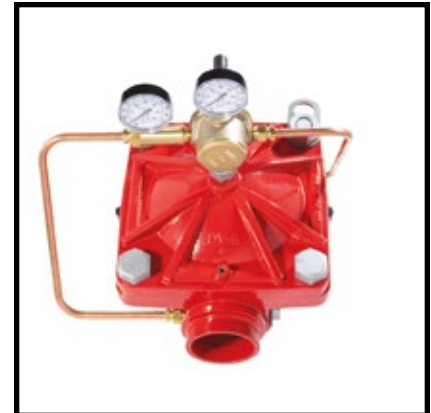

NOTICE

The TYCO Model PRV-1A Pressure Reducing Valves described herein must be installed and maintained in compliance with this document and with the applicable standards of the NATIONAL FIRE PROTECTION ASSOCIATION (NFPA), in addition to the standards of any authorities having jurisdiction. Failure to do so may impair the performance of these devices.

Owners are responsible for maintaining their fire protection system and devices in proper operating condition. Contact the installing contractor or sprinkler manufacturer with any questions.

Due to the flow regulating characteristic of this device, its impact on system hydraulics should be carefully considered, especially when retrofitted into existing systems.

End Connection	Available End Connections					
	Nominal Valve Size in. (DN)					
	2 (DN50)	3 (DN80)	4 (DN100)	6 (DN150)	165,1 mm	8 (DN200)
Groove x Groove	✓	✓	✓	✓	✓	✓
Flange x Flange (ANSI)	N/A	✓	✓	✓	✓	✓
Flange x Flange (PN) ¹	N/A	✓	✓	✓	✓	✓

NOTES:
1. EMEA and APAC only.

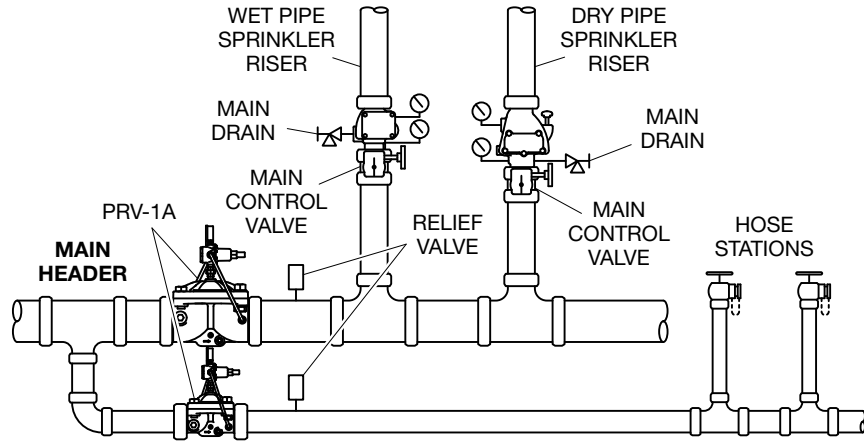

FIGURE 1
MODEL PRV-1A PRESSURE REDUCING VALVE
TYPICAL MAIN HEADER APPLICATION

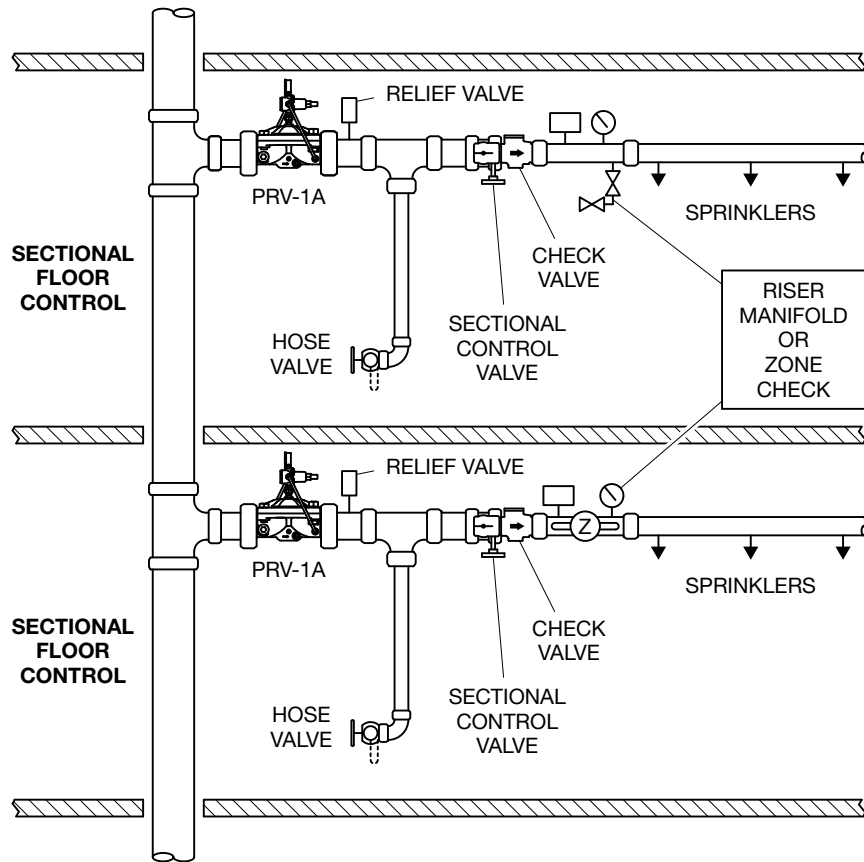

FIGURE 2
MODEL PRV-1A PRESSURE REDUCING VALVE
TYPICAL SECTIONAL FLOOR CONTROL APPLICATION

Item	Description	Qty.	Nominal Valve Size ANSI Inch (DN)				
			2 (DN50)	3 (DN80)	4 (DN100)	6 (DN150) ^e	8 (DN200)
			P/N	P/N	P/N	P/N	P/N
1	Valve Body	1	N/R	N/R	N/R	N/R	N/R
2	Diaphragm	1	545000020	545000030	545000040	545000060	545000080
3	Diaphragm Cover	1	N/R	N/R	N/R	N/R	N/R
4	Hex Bolt, Short	2 ^a	545100001	545100002	545100003	545100004	545100003
5	Hex Bolt, Long	2	545100011	545100012	545100013	545100014	545100015
6	Lift Washer	2 ^b	N/A	545100021	545100022	545100023	545100022
7	Hex Nut	2	545100031	545100032	545100033	545100034	545100033
8	Hoist Ring	2	545100041	545100041	545100041	545100041	545100041
9	Flat Washer	2	N/A	545100024	545100025	545100026	545100025

NOTES:

- a. Hex Bolt, Short, Qty. 6 in 6 and 8 inch (DN150 and DN200) assemblies
- b. Lift Washer not used in 2 inch (DN50) assembly
- c. N/R = Not Replaceable

- d. Order replacements parts only via Part Numbers given, do not replace Hex Bolt, Hex Nut, Lift Washer or Hoist Ring with common hardware parts
- e. Also applicable to metric 165,1 mm size.

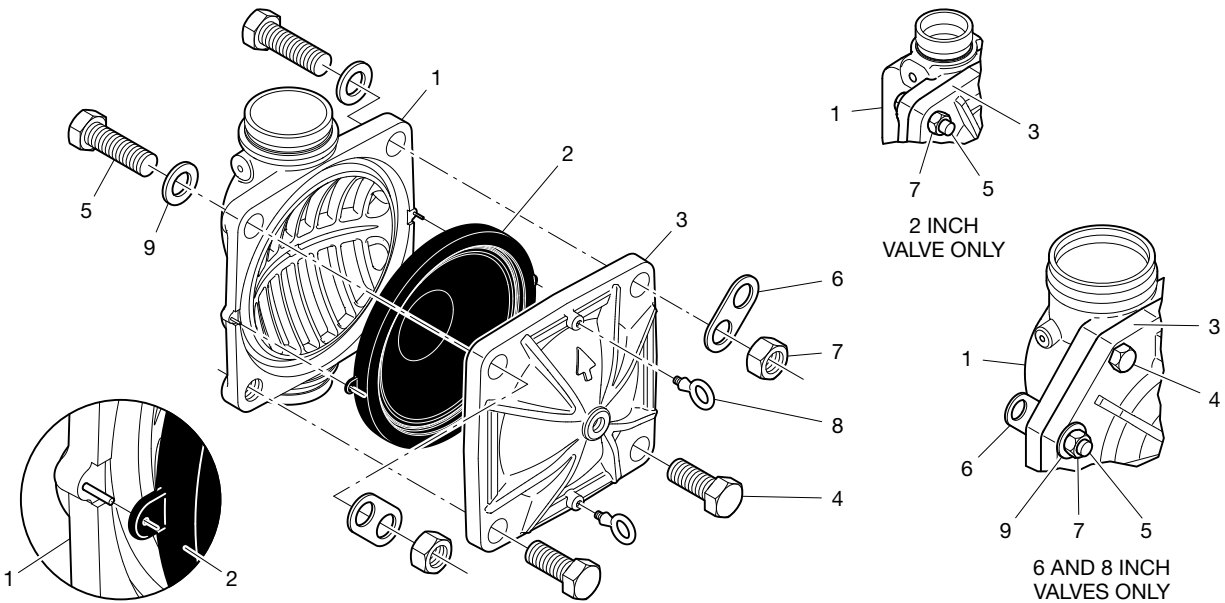
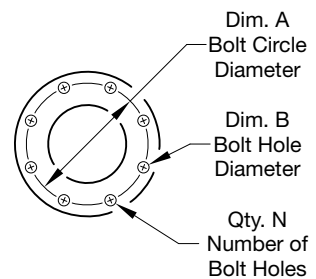

FIGURE 3
DV-5A VALVE ASSEMBLY AND REPLACEMENT PARTS
 (See Figure 7 For PRV-1A Trim Assembly)

Nominal Valve Size ANSI in. (DN)	Flange Drilling Specification			Nominal Valve Size ANSI in. (DN)	Flange Drilling Specification		
	Nominal Dimensions in. (mm)				Nominal Dimensions in. (mm)		
	ANSI B16.1 ^a (Class 125)				ISO 7005-2 (PN16) ^b		
	A	B	N		A	B	N
3 (DN80)	6.00 (152,4)	0.75 (19,0)	4	3 (DN80)	6.30 (160,0)	0.75 (19,0)	8
4 (DN100)	7.50 (190,5)	0.75 (19,0)	8	4 (DN100)	7.09 (180,0)	0.75 (19,0)	8
6 (DN150)	9.50 (241,3)	0.88 (22,2)	8	6 (DN150)	9.45 (240,0)	0.91 (23,0)	8
8 (DN200)	11.75 (298,5)	0.88 (22,2)	8	8 (DN200)	11.61 (295,0)	0.91 (23,0)	12



NOTES:

- a. Same drilling as for ANSI B16.5 (Class 150) and ANSI B16.42 (Class 150)
- b. Same drilling as for BS 4504 Section 3.2 (PN16) and DIN 2532 (PN16)

TABLE A
FLANGE DRILLING SPECIFICATIONS

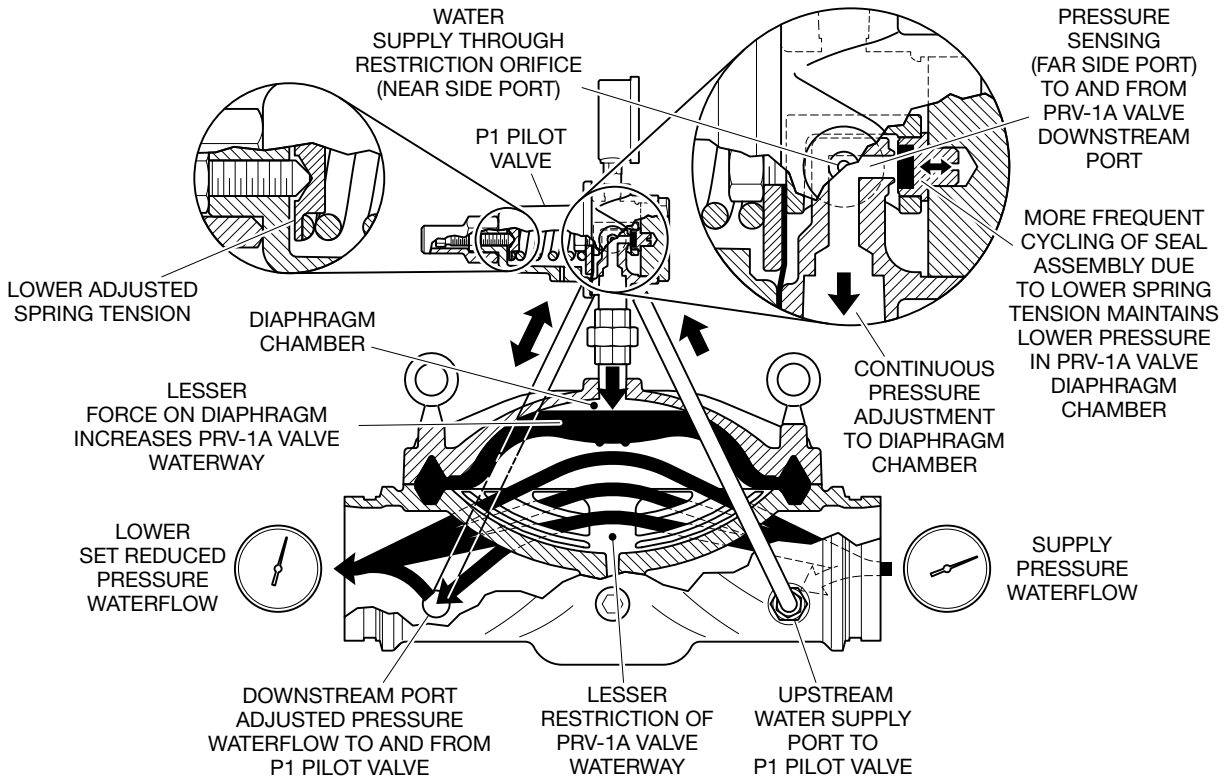

LOWER SET PRESSURE CONDITION

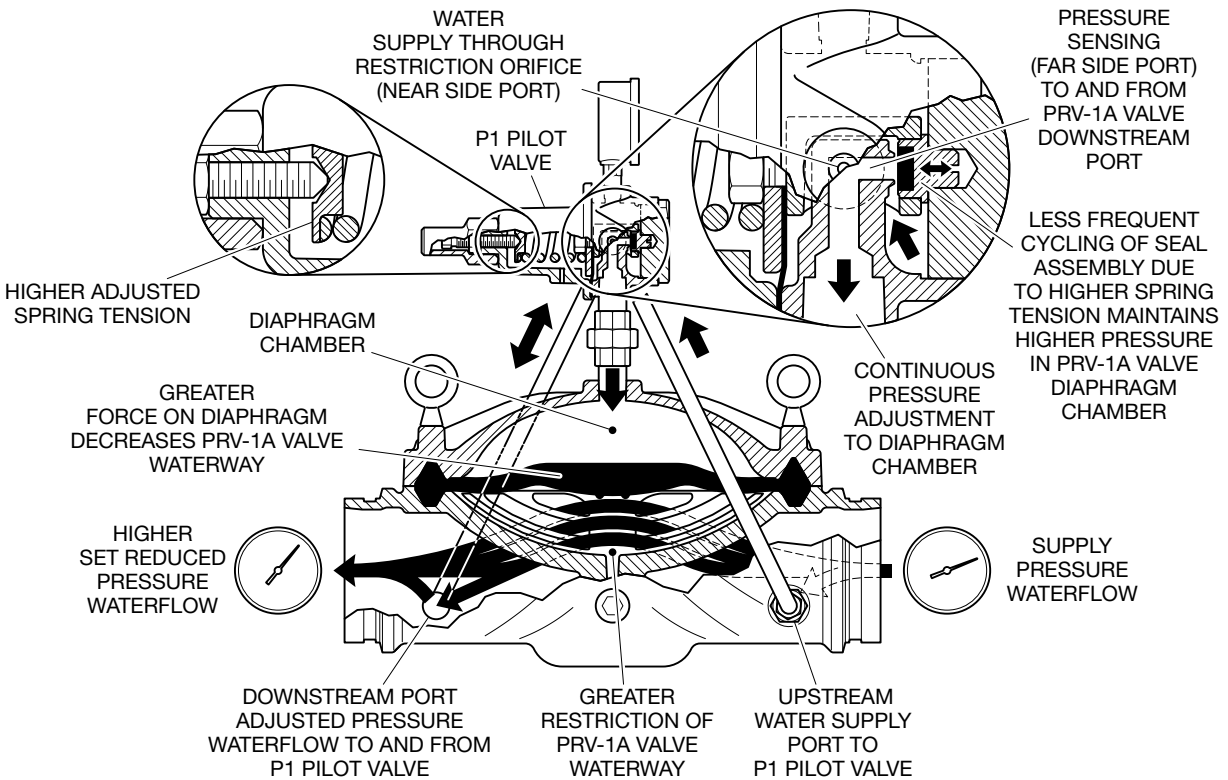

HIGHER SET PRESSURE CONDITION

FIGURE 4
MODEL PRV-1A PRESSURE REDUCING VALVE
OPERATION

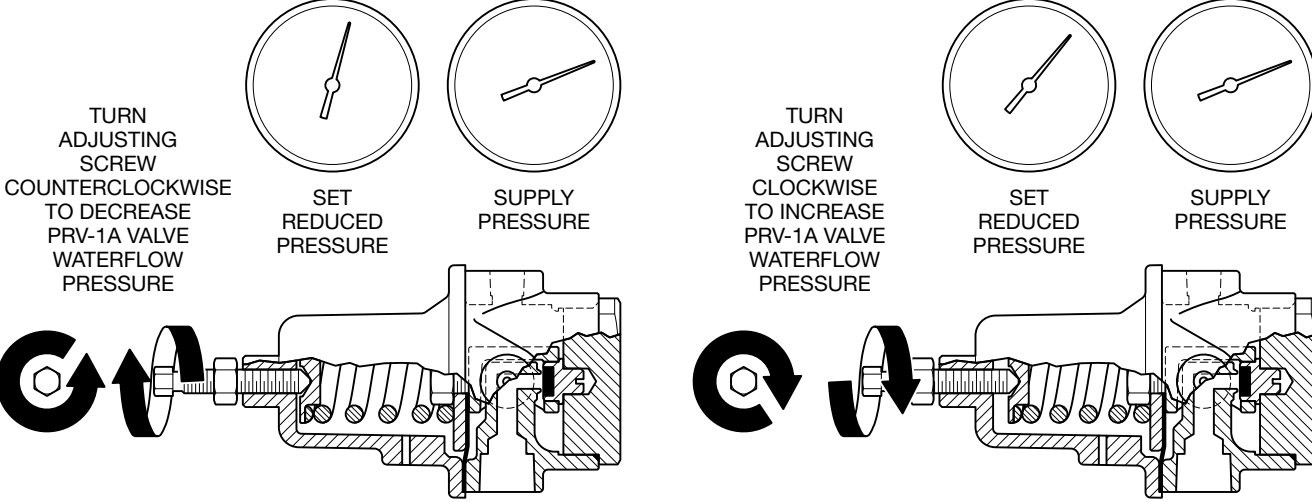

LOWER SET PRESSURE CONDITION

HIGHER SET PRESSURE CONDITION

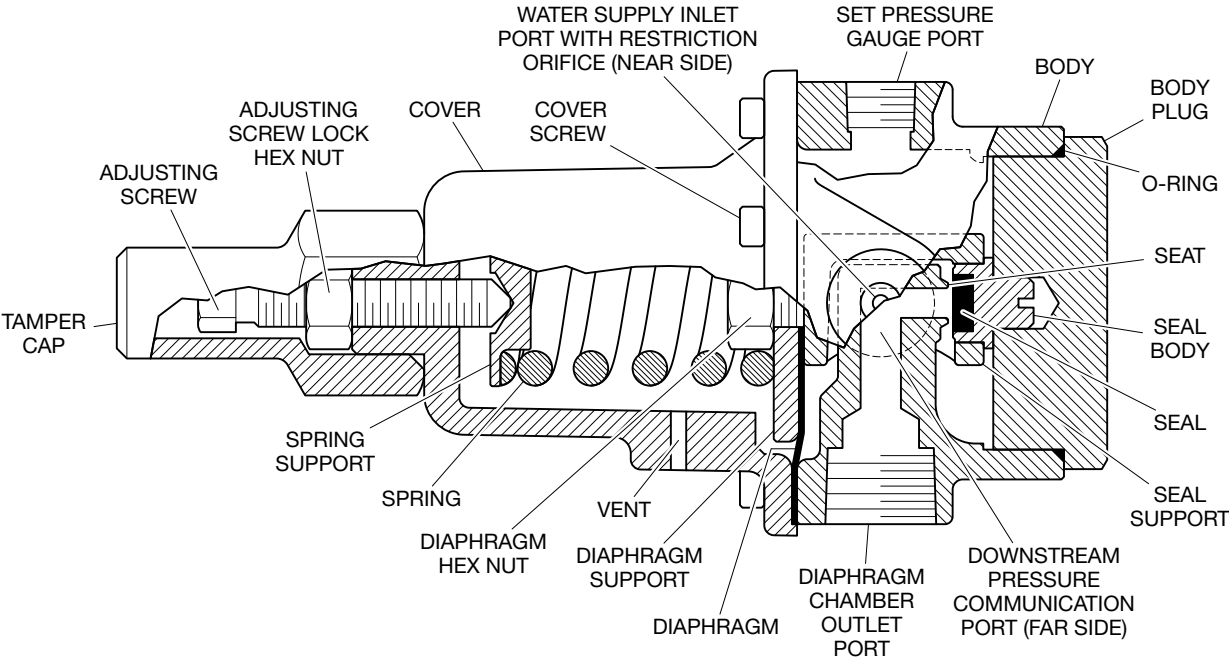
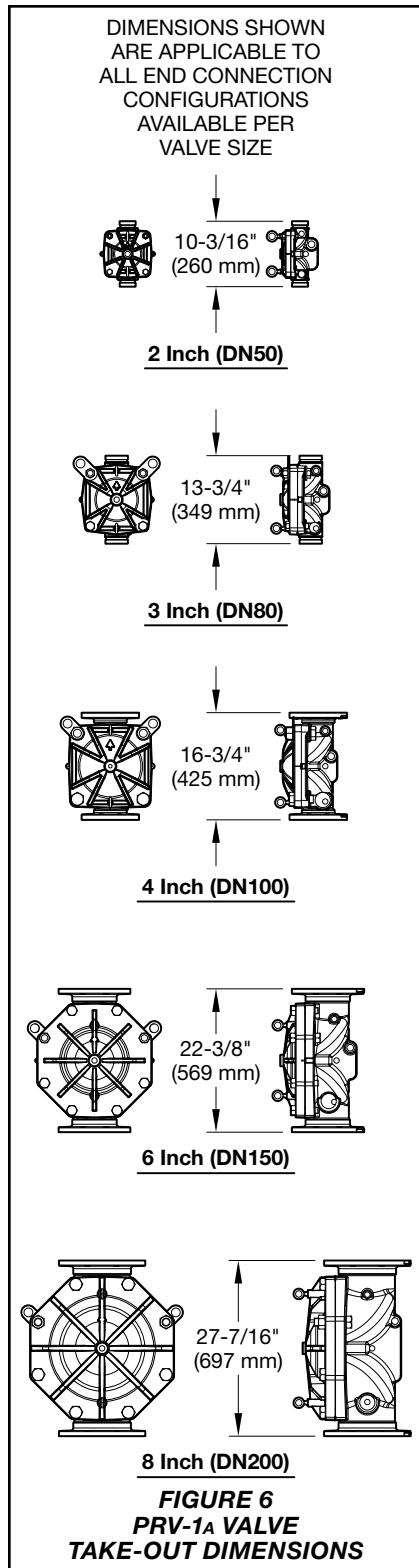

FIGURE 5
MODEL PRV-1A PRESSURE REDUCING VALVE
MODEL P1 PILOT VALVE ASSEMBLY AND ADJUSTMENT



Technical Data

Approvals

UL and C-UL Listed (2 in. to 6 in. only)
FM Approved

The UL Listing is based on the following factors:

- Installation requirements referenced in the Standard for Installation of Sprinkler Systems, NFPA 13, or the Standard for Installation of Standpipe and Hose Valves, NFPA 14, as applicable.
- Inspection, testing, and maintenance requirements referenced in the Standard for Inspection, Testing, and Maintenance of Water-Based Fire Protection Systems, NFPA 25.
- Filed-setting of the Model PRV-1A Valve to provide required outlet pressures and flows for the given application.
- Testing of the Model PRV-1A Valve after installation in accordance with NFPA 13 and/or NFPA 14 as applicable.
- Testing the Model PRV-1A Valve periodically thereafter in accordance with NFPA 25.

Note: UL/C-UL Approval is based on the use of the 3/4 in. CLA-VAL Model 55L-60 pressure relief valve.

Maximum Inlet Pressure

2 in. (DN50)	250 psi (17.2 bar)
3 in. (DN80)	300 psi (20.7 bar)
4 in. (DN100)	300 psi (20.7 bar)
6 in. (DN150)	300 psi (20.7 bar)
8 in. (DN200)	300 psi (20.7 bar)

Factory Outlet "Set Pressure"

125 psi (8,6 bar)

Field Outlet "Set Pressure" Range

90 to 175 psi (6,2 to 12 bar)*

* = Sizes 2, 3, 6 and 8 in. are rated to a set pressure of 80 to 175 psi (5,5 to 12 bar)

Pressure Loss With Inlet Pressure Above "Set Pressure"

The inlet pressure minus the outlet "set pressure" equals pressure loss. For example, assuming that the inlet flowing pressure is 225 psi (15,5 bar) and the field outlet "set pressure" is 130 psi (9,0 bar), the pressure loss is 95 psi (6,5 bar).

Pressure Loss with Inlet Pressure Below "Set Pressure"

See Graphs A to E. These graphs are a requirement of UL and should be used as reference only.

Rated Flowing Range

2 in. (DN50)	25 to 260 gpm (95 to 984 Lpm)
3 in. (DN80)	25 to 500 gpm (95 to 1893 Lpm)
4 in. (DN100)	25 to 1000 gpm (95 to 3785 Lpm)
6 in. (DN150)	25 to 1300 gpm (95 to 4920 Lpm)
8 in. (DN200)	100 to 4000 gpm (379 to 15141 Lpm)

Note: Rated flowing range is the flow range tested by the approval agencies.

End Connections

- Flanged end connections are available as drilled per Table A.
- Grooved end connections follow industry standard groove specifications.

Valve Materials of Construction

See Figure 3

Body

Epoxy-coated ductile iron per ASTM A536-77, Grade 65-45-12

Diaphragm Cover

Epoxy coated ductile iron per ASTM A536-77, Grade 65-45-12

Diaphragm

Polyester fabric-reinforced, TEFLON coated, EPDM rubber per ASTM D2000

Diaphragm Cover Fasteners

Aluminium-zinc coated steel

Trim Materials of Construction

See Figure 7

Pilot Valve

Cast bronze and stainless steel with fabric reinforced, EPDM rubber per ASTM D2000 diaphragm

Pressure Gauges

3 3/4 in. (95 mm) diameter, UL and FM listed, 0 to 300 psi (0 to 20,7 bar)

Strainer, Tube, and Fittings

Stainless steel

Operation

With reference to Figure 4, the system water supply pressure from the inlet cavity of the Model PRV-1A Valve enters the Diaphragm Chamber through a Strainer.

Exit flow from the Diaphragm Chamber through the Pilot Valve is controlled by a regulating spring that is factory set, and subsequently field adjustable, to the desired downstream “set pressure” that is to be maintained. A sensing line connects the outlet of the Pilot Valve to the system piping downstream of the Model PRV-1A Valve via the Pressure Sensor Insert in the outlet cavity.

When the downstream pressure rises above the “set pressure” of the spring, exit flow from the Diaphragm Chamber through the Pilot Valve to the Model PRV-1A Valve outlet cavity is stopped and pressure increases in the Diaphragm Chamber. When downstream pressure falls below the “set pressure” of the spring, exit flow from the Diaphragm Chamber through the Pilot Valve to the Model PRV-1A Valve outlet cavity resumes and pressure in the Diaphragm Chamber decreases.

The regulated flow through the Pilot Valve decreases and increases the pressure in the diaphragm chamber to sufficiently open and close the Model PRV-1A Valve, as required, to regulate the downstream “set pressure”.

The operation sequence is as follows:

- When there is no flow demand downstream of the Model PRV-1A Valve, the Seat is closed and the Pilot Valve Seat is closed. With the Pilot Valve Seat closed, pressure is trapped in the Diaphragm Chamber to seat the Diaphragm and the Model PRV-1A Valve remains closed.
- When there is a flow demand downstream of the Model PRV-1A Valve and the outlet pressure drops below the “set pressure”, the Pilot Valve Seat opens to relieve pressure from the Diaphragm Chamber allowing the Model PRV-1A Valve to open.
- As the flow demand continues downstream of the Model PRV-1A Valve and the “set pressure” is met, the Pilot Valve Seat closes. As the Pilot Valve Seat closes to reduce the opening, pressure is trapped in the Diaphragm Chamber at a point that allows the Diaphragm to remain lifted from the Model PRV-1A Valve Seat to retain the downstream “set pressure”.
- Should the downstream pressure start to fall below the “set pressure”, the Pilot Valve Seat re-opens to allow for a decrease in pressure in the Diaphragm Chamber to allow the Model PRV-1A Valve to open further and then once again establish the downstream “set pressure”.
- When the downstream pressure is at or above the “set pressure” and assuming there is a flow demand downstream of the Model PRV-1A Valve, the Pilot Valve Seat is closed to trap a sufficient pressure in the Diaphragm Chamber to allow the Model PRV-1A Valve to remain open to provide the “set pressure”.

Design Considerations

The following items must be considered and applied accordingly for an installation that will be using the Model PRV-1A Pressure Reducing Valve:

- When planning the positioning of the Model PRV-1A Valve, it is recommended that consideration be given to the viewing of the pressure gauges. Consideration should also be given to positioning the Model PRV-1A Valve so that the diaphragm cover is facing up. With the cover facing up, internal access is more easily achieved.
- The Model PRV-1A Valve must be in an area that is easily accessible for maintenance purposes, not subject to freezing temperatures, and not subject to physical damage.
- The valve is designed for fresh water service. When corrosive atmospheres and/or contaminated water supplies are present, it is the owner's responsibility to verify compatibility with the pressure reducing valve, pilot valve, and trim.
- The difference between the water supply pressure and the desired outlet (downstream) pressure must be 25 psi (1,7 bar) or greater per its FM Approval or 50 psi (3,4 bar) or greater per its UL Listing. The differential maintains accuracy control of the discharging pressure over the full rated flowing range.
- Cavitation may occur when the inlet pressure is greater than twice the “set pressure”. For this case, the pressure should be reduced in two steps by using two Model PRV-1A Valves in series.
- When reducing pressure for a sprinkler system, a 3/4 in. (DN15) or larger pressure relief valve shall be located downstream of the Model PRV-1A Valve. The pressure relief valve shall be set at a pressure 10 psi (0,7 bar) lower than the pressure rating of the lowest pressure rated component downstream of the Model PRV-1A Valve.
- When reducing pressure for a sprinkler system, a listed indicating valve shall be provided on the inlet side of the Model PRV-1A Valve.
- When reducing pressure for a sprinkler system, means shall be provided downstream of the Model PRV-1A Valve to facilitate a flow test at the sprinkler system demand.

ITEM	QTY	DESCRIPTION	CH	2 IN. (DN50)	3 IN. (DN80)	4 IN. (DN100)	6 IN. (DN150) ^a	8 IN. (DN200)
1	1	DV-5a AUTOMATIC WATER CONTROL VALVE						
2	1	P1 PILOT VALVE, 0.125 IN. (3,2 mm) RESTRICTION		545100068	545100068	545100068	545100068	—
	1	P1 PILOT VALVE, 0.250 IN. (6,4 mm) RESTRICTION		—	—	—	—	545100101
3	2	WATER PRESSURE GAUGE, 300 PSI / 2000 kPa		92-343-1-005	92-343-1-005	92-343-1-005	92-343-1-005	92-343-1-005
4	1	TUBING ASSEMBLY, DV-5a P1 INTERCONNECT TUBE 1		545100074	545100075	545100076	545100077	545100078
5	1	TUBING ASSEMBLY, DV-5a P1 INTERCONNECT TUBE 2		545100079	545100080	545100081	545100082	545100083
6	1	FLARE FITTING 1/4 IN. GAUGE ADAPTER 1/2 IN. NPT x 1/2 IN. TUBE		545100072	545100072	545100072	545100072	545100072
7	1	FLARE FITTING STRAINER 1/2 IN. NPT x 1/2 IN. TUBE		545100073	545100073	545100073	545100073	545100073
8	1	FLARE FITTING 1/2 IN. NPT x 1/2 IN. TUBE x 0.250 IN. (6,4 mm) RESTRICTION		545100106	545100106	—	—	—
	1	FLARE FITTING 1/2 IN. NPT x 1/2 IN. TUBE x 0.406 IN. (10,3 mm) RESTRICTION		—	—	545100061	545100061	545100061
9	1	FLARE FITTING 1/2 IN. NPT x 1/2 IN. TUBE		545100061	545100061	545100061	545100061	545100061
10	1	1/2 IN. UNION	✓	1/2 IN.	1/2 IN.	1/2 IN.	1/2 IN.	1/2 IN.
11	2	1/2 IN. x CLOSE PIPE NIPPLE	✓	1/2 IN. x CLOSE	1/2 IN. x CLOSE	1/2 IN. x CLOSE	1/2 IN. x CLOSE	1/2 IN. x CLOSE
12	1	1/2 IN. SOCKET HEAD PIPE PLUG	✓	1/2 IN.	1/2 IN.	1/2 IN.	1/2 IN.	1/2 IN.
13	2	3/4 IN. SOCKET HEAD PIPE PLUG	✓	3/4 IN.	3/4 IN.	3/4 IN.	3/4 IN.	3/4 IN.
14	1	PIPE PLUG	✓	3/4 IN.	1 1/4 IN.	2 IN.	2 IN.	2 IN.

NOTES:

a. Also applicable to metric 165,1 mm size.

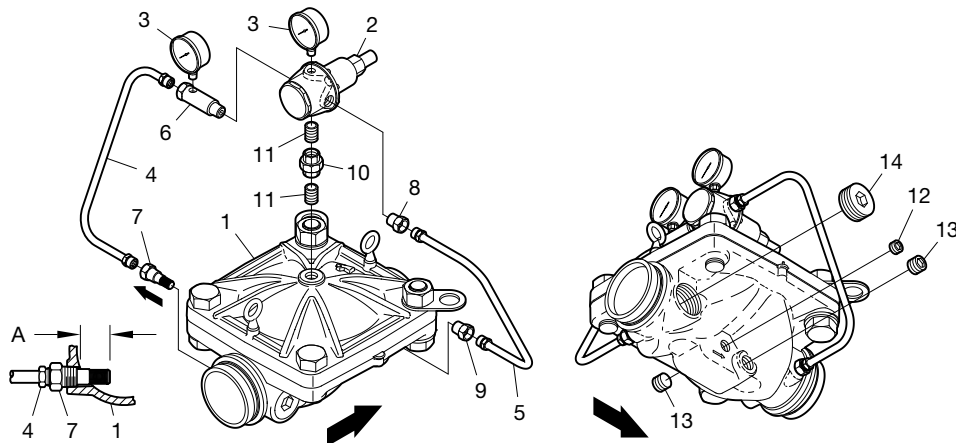

FIGURE 7
MODEL PRV-1a PRESSURE REDUCING VALVE
TRIM ASSEMBLY

Nominal Valve Sizes in. (DN)	O.D. Pipe Size in. (mm)	Nominal Installation Dimensions in. (mm)					Approx. Weight lb (kg)
		A	B	C	D	E	
2 (DN50)	2.88 (60,3)	10 3/16 (260)	2.80 (71,1)	11.09 (281,7)	6.28 (159,5)	8.94 (227,1)	35.0 (15,9)
3 (DN80)	3.50 (88,9)	13 3/4 (349)	2.95 (74,9)	12.77 (324,4)	7.78 (197,6)	8.94 (227,1)	71.0 (32,2)
4 (DN100)	4.50 (114,3)	16 3/4 (425)	3.00 (76,2)	14.12 (358,6)	8.44 (214,4)	8.44 (214,4)	106.0 (48,1)
6 (DN150) ^a	6.62 (168,3)	22 7/16 (569)	4.52 (114,8)	15.41 (391,4)	11.78 (299,2)	10.94 (277,9)	188.0 (85,3)
8 (DN200)	8.62 (219,1)	27 7/16 (697)	5.29 (134,4)	18.11 (460,0)	14.78 (375,4)	14.44 (366,8)	338.0 (153,3)

NOTES:

a. Also applicable to metric 165,1 mm size.

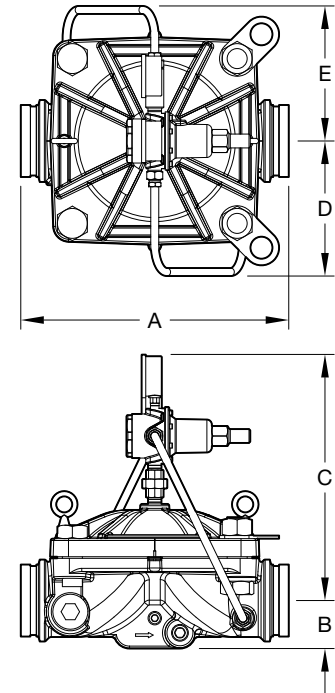

FIGURE 8
MODEL PRV-1A PRESSURE REDUCING VALVE
GROOVE x GROOVE END CONNECTIONS
NOMINAL INSTALLATION DIMENSIONS

Nominal Valve Sizes in. (DN)	Nominal Installation Dimensions in. (mm)					Approx. Weight lb (kg)
	A	B	C	D	E	
3 (DN80)	13 3/4 (349)	4.00 (101,6)	12.77 (324,4)	7.78 (197,6)	8.94 (227,1)	83.0 (37,6)
4 (DN100)	16 3/4 (425)	4.42 (112,3)	14.12 (358,6)	8.44 (214,4)	8.44 (214,4)	127.0 (57,6)
6 (DN150) ^a	22 7/16 (569)	5.41 (137,4)	15.41 (391,4)	11.78 (299,2)	10.94 (277,9)	215.0 (97,5)
8 (DN200)	27 7/16 (697)	6.76 (171,7)	18.11 (460,0)	14.78 (375,4)	14.44 (366,8)	376.0 (170,6)

NOTES:

a. Also applicable to metric 165,1 mm size.

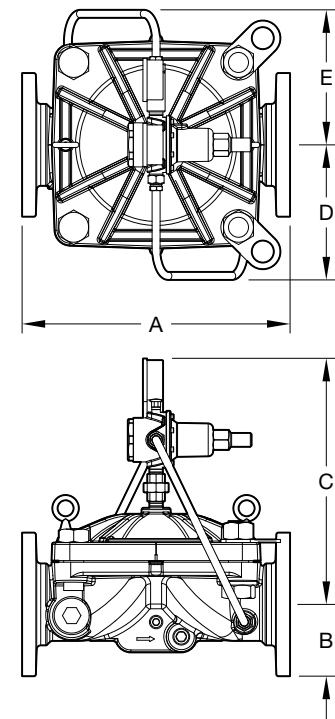

FIGURE 9
MODEL PRV-1A PRESSURE REDUCING VALVE
FLANGE x FLANGE END CONNECTIONS
NOMINAL INSTALLATION DIMENSIONS

Installation

Note: The valve may be installed in any orientation (horizontal, diaphragm cover facing up, and vertical) provided the gauges are readable from a safe position and the valve can be adequately inspected in accordance with NFPA 25.

The TYCO Model PRV-1A Pressure Reducing Valve must be installed with the flow arrow located on the Diaphragm Cover pointing in the intended direction of flow. Installation dimensions are provided in Figures 8 and 9.

Before the Model PRV-1A Valve is installed, pipe lines should be flushed of all chips, scale and foreign matter. Care must be exercised to assure that the trim is not damaged during installation.

NOTICE

Do not lift the valve by its trim. Otherwise, the trim may be damaged and impair system operation. The inlet and outlet connections must be made based on the direction of flow arrow provided on the Diaphragm Cover. The valve cannot operate if connected backwards.

Do not alter the trim. Altering the trim voids the approvals listing of the valve and may impair system performance.

Placing the Valve in Service

Perform the following steps to place the TYCO Model PRV-1A Pressure Reducing Valve in service.

WARNING

Downstream pressure adjustment is only to be performed by experienced personnel who understand the impact of adjusting the downstream pressure and who take full responsibility of the readjustment from the factory setting. The Pilot Valve is provided with a Tamper Cap, which upon removal will allow for field adjustment by using the Adjusting Screw.

Per the requirements of NFPA 13, a means shall be provided downstream of the Model PRV-1A Valve to simulate the sprinkler system demand. In the case of hose stations, the opening of a hose valve or multiple hose valves, as required, will be necessary to simulate hose stream demand.

For the purposes of the following instruction, the opening of a “flow test valve” simulates either the sprinkler demand or hose stream demand, as applicable. The sprinkler demand or hose stream demand must be

at least 50 gpm (190 Lpm) for 2 to 6 in. (DN50 to DN150) valves and at least 100 gpm (380 Lpm) for 8 in. (DN200) valves.

There is no need to vent any trapped air from the Diaphragm Chamber.

Filling the System

Step 1. Verify that the downstream drain valves are closed and that there are no leaks.

Step 2. Partially open a valve or valves at the end of the system, such as an inspector’s test connection on a wet pipe system, to allow trapped air to escape when filling the system.

Step 3. Slowly and partially open the water supply control valve feeding the Model PRV-1A Valve.

Step 4. After the system fills with water, close the valve or valves that had been partially opened in Step 2.

Step 5. Completely open the main water supply control valve feeding the Model PRV-1A Valve.

Adjusting Downstream Pressure

NOTICE

After any downstream pressure adjustment, the following items are to be recorded on a tag attached to the valve:

- Valve installation location
- Inlet static pressure
- Outlet static pressure
- Inlet residual pressure
- Outlet residual pressure
- Intended outlet flow

The tag is not to be removed until after the system has been accepted by the authority having jurisdiction. It is recommended that the tag not be removed even after acceptance by the authority having jurisdiction unless another means of record keeping is maintained.

Step 1. Remove the Tamper Cap from the Pilot Valve by first loosening its set screw and then unscrewing the Tamper Cap.

Step 2. Open the “flow test valve” to simulate either the desired sprinkler demand or hose stream demand.

Step 3. If surging flow occurs, attempt to bleed trapped air from the system via the inspector’s test valve and any other valve that can vent trapped air.

Step 4. Loosen the locknut on the adjusting screw of the Pilot Valve.

Step 5. Turn the adjusting screw clockwise to increase outlet pressure or counterclockwise to decrease outlet pressure.

Step 6. After achieving the desired performance, tighten the locknut on the adjusting screw.

Step 7. Slowly reduce the flow through the valve by closing the “flow test valve” over the course of at least 30 seconds. Observe the outlet pressure gauge and compare to the required “set pressure”. If the required “set pressure” is not achieved, repeat Step 2 and proceed accordingly. Replace the Tamper Cap and tighten its set screw.

NOTICE

After setting the PRV-1A for service, record the installation location, static pressure at the inlet, residual pressure at the inlet, static pressure at the outlet, intended flow at the outlet, and residual pressure at the outlet on the paper field tag included with the valve trim. Attach the tag to the front of the valve.

WARNING

If the “flow test valve” is closed rapidly it can cause a spike in downstream pressure.

The pressure reducing valve is now set for service.

Due to the spring tolerance within the Pilot Valve, it may be necessary to alternate back and forth between residual and static conditions to achieve the desired “set pressure” for both residual and static conditions.

Care and Maintenance

The TYCO Model PRV-1A Pressure Reducing Valve must be maintained and serviced in accordance with this section. Before closing a fire protection system main control valve for maintenance work on the fire protection system that it controls, obtain permission to shut down the affected fire protection system from the proper authorities and notify all personnel who may be affected by this action.

NOTICE

Inspection, testing, and maintenance must be performed in accordance with the requirements of the NFPA, and any impairment must be immediately corrected.

Responsibility lies with sprinkler owners for the inspection, testing, and maintenance of their fire protection system and devices in compliance with this document, as well as with the applicable standards of the NFPA for example, NFPA 25, in addition to the standards of any other authorities having jurisdiction. Contact the installing contractor or product manufacturer with any questions.

Nominal Valve Sizes ANSI Inches (DN)	Torque lb-ft (N·m)	
	Nuts	Short Hex Bolts
2 (DN50)	44 (59,7)	35 (47,5)
3 (DN80)	125 (169,5)	125 (169,5)
4 (DN100)	150 (203,4)	150 (203,4)
6 (DN150) ^a	150 (203,4)	150 (203,4)
8 (DN200)	188 (254,9)	188 (254,9)

NOTES:
a. Also applicable to metric 165,1 mm size.

**TABLE B
DIAPHRAGM COVER BOLTS
MINIMUM TORQUE**

Automatic sprinkler systems are recommended to be inspected, tested, and maintained by a qualified Inspection Service in accordance with local requirements and/or national code.

The Model PRV-1A Pressure Reducing Valve requires no lubrication, packing or preventative maintenance; however, replacement of the diaphragm every five years is recommended.

Flow Tests

Flow tests per NFPA are required every five years, at which point the outlet pressure is compared to previous tests. If necessary the Model PRV-1A Valve can be readjusted following the Placing the Valve in Service section. If the desired pressure cannot be achieved, the Diaphragm and/or Pilot Valve should be replaced.

Diaphragm Replacement

Prior to replacing the Diaphragm, the Model PRV-1A Valve must be taken out of service and completely drained. The Diaphragm Tab is oriented perpendicular to the outlet flow.

When reinstalling the Diaphragm Cover, the Diaphragm Cover Fasteners (Hex Bolts) must be uniformly and securely tightened using a cross-draw sequence. After tightening, double check to make certain that all of the Diaphragm Cover fasteners are securely tightened.

After cleaning and inspecting valve interior, and replacing parts as necessary, reinstall the Diaphragm Cover by completing the following steps to assure the Diaphragm Cover Fasteners are uniformly and securely tightened.

Step 1. Ensure that the Diaphragm is properly oriented and that the proper hardware arrangement is utilized when assembling the Diaphragm Covers. The hardware arrangements differ depending on the size of the DV-5A Valve.

Step 2. By first using the Long Hex Bolts, support of the Diaphragm Cover will be provided before installing the Short Hex Bolts. Align Diaphragm in proper orientation with Valve Body, and then align Diaphragm Cover in proper orientation with Valve Body. Hand-tighten all fasteners.

Step 3. Using crossdraw sequence to assure uniformity, wrench-tighten Long Hex Bolts and Short Hex Bolts to appropriate torque values. Repeat crossdraw sequence two to three times at incremental torque valves until reaching the torque values found in Table B.

Step 4. Inspect to assure all Hex Bolts are securely tightened.

Step 5. Using the union, secure the PRV-1A to the Diaphragm cover.

Step 6. Using the union, secure the PRV-1A trim.

Step 7. Ensure that the unions and pipe nipples flare fittings are securely tightened.

Pilot Valve Replacement

Prior to removing the Pilot Valve, the Model PRV-1A Valve must be taken out of service and completely drained. When installing the replacement Pilot Valve, the trim components must be replaced exactly as they were. After reinstalling the Pilot Valve and before returning the Model PRV-1A Valve into service, completely unscrew the Adjusting Screw of the replacement Pilot Valve so as to obtain a minimum outlet “set pressure”. Then proceed to use the instructions under Placing The Valve In Service section to place the Model PRV-1A Valve in service.

NOTICE

The Pilot Valve is not field repairable. Attempting to repair the Pilot Valve may render the valve ineffective and impair the system operation.

Completely unscrewing the Adjusting Screw of the replacement Pilot Valve will help to avoid an accidental over pressurization of the system piping prior to achieving the desired “set pressure”.

Strainer Maintenance

Prior to performing strainer maintenance, the Model PRV-1A Valve must be taken out of service and completely drained. Be prepared for small amounts of residual liquid when disconnecting any trim part. See Figures 4 and 5 to identify parts and key features.

Step 1. Loosen the compression fitting on the supply line.

Step 2. Disconnect the compression fitting on the supply line at the strainer outlet and swing the supply line away for access.

Step 3. Remove the inlet pressure gauge and trim as sub-assembly from the strainer outlet.

Note: When removing, do not grip the gauge itself, loosen the sub-assembly by wrench on the fitting closest to strainer only.

Step 4 Remove the strainer from the valve body.

Step 5. Disassemble the strainer for cleaning. Remove the end lock washer and slide the screen off the strainer body. Clean the screen and body.

Step 6. Reassemble the screen onto the body and secure with a lock washer.

Note: Prior to installing the strainer and gauge and trim sub-assembly, clean all exposed male NPT pipe threads and apply TEFLON tape as required. Do not apply sealant to male threads of the separated compression fitting. Do not contaminate the strainer screen.

Step 7. Install the strainer into the valve body. Install the gauge and the trim sub-assembly into the strainer outlet.

Step 8. Reconnect the supply line compression fitting to the strainer outlet trim and tighten the compression fitting on the supply line.

For more information on how to place the Model PRV-1A Valve in service, see the Placing the Valve in Service section.

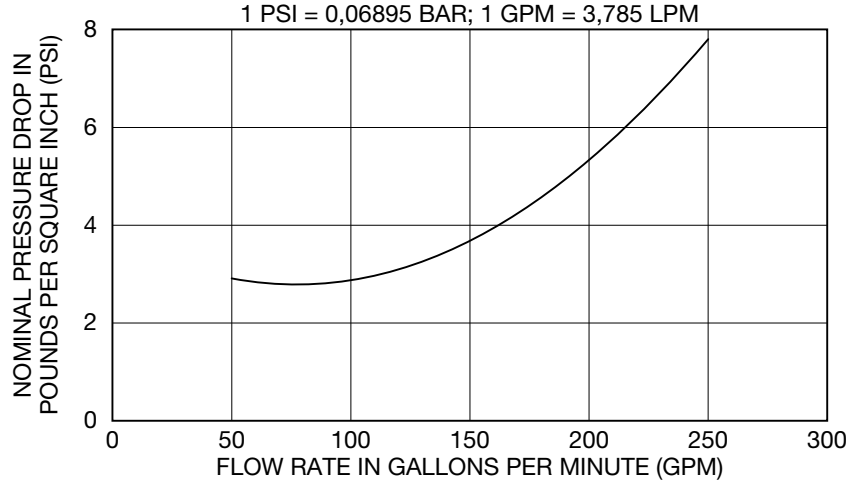

GRAPH A
2 INCH (DN50) PRV-1A PRESSURE REDUCING VALVE
MINIMUM PRESSURE DROP

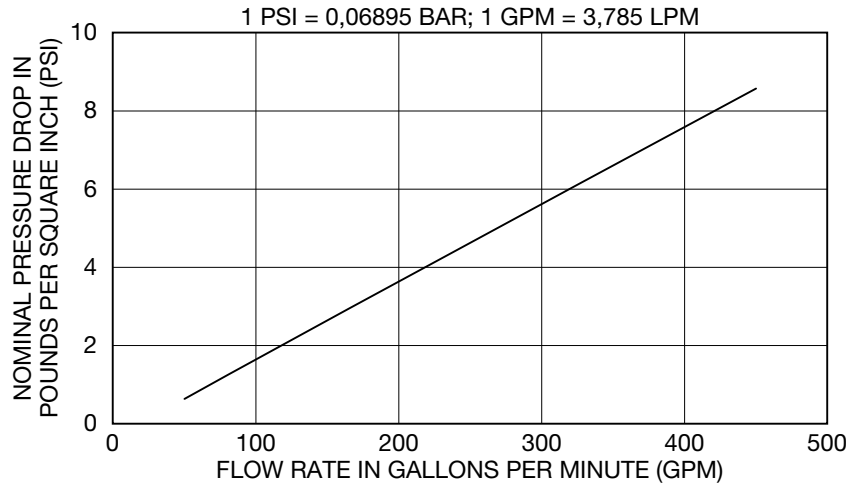

GRAPH B
3 INCH (DN80) PRV-1A PRESSURE REDUCING VALVE
MINIMUM PRESSURE DROP

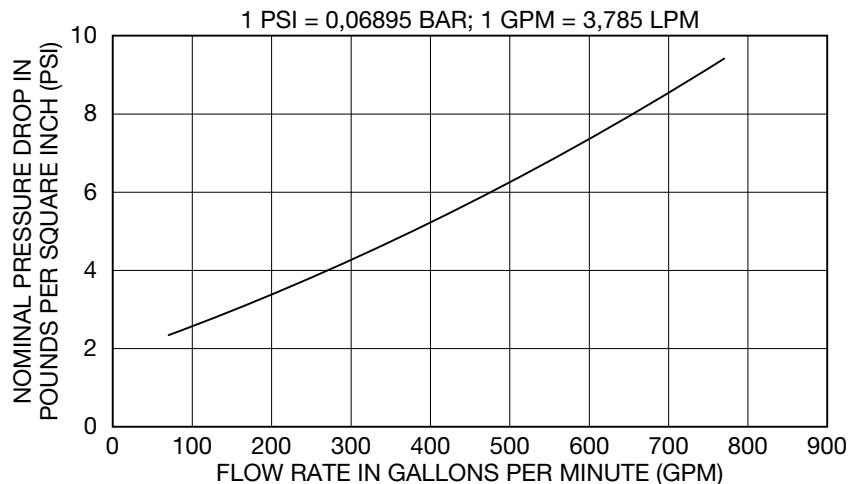

GRAPH C
4 INCH (DN100) PRV-1A PRESSURE REDUCING VALVE
MINIMUM PRESSURE DROP

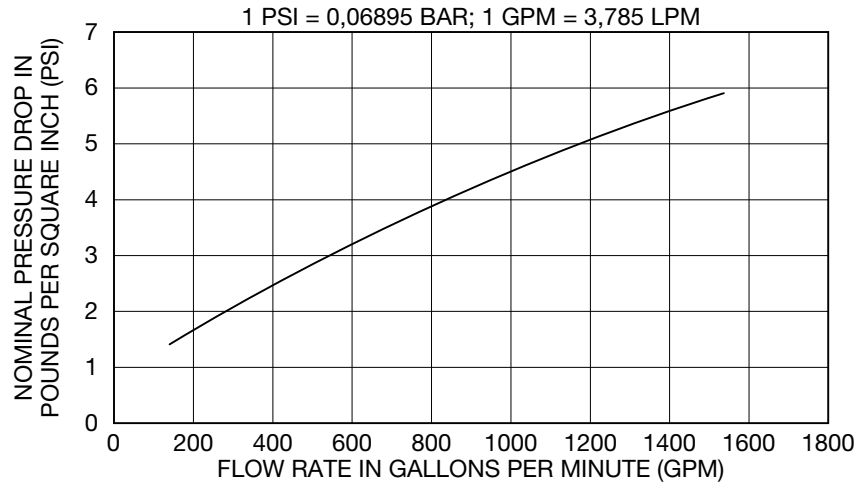

GRAPH D
6 INCH (DN150) AND 165,1 MM PRV-1A PRESSURE REDUCING VALVE
MINIMUM PRESSURE DROP

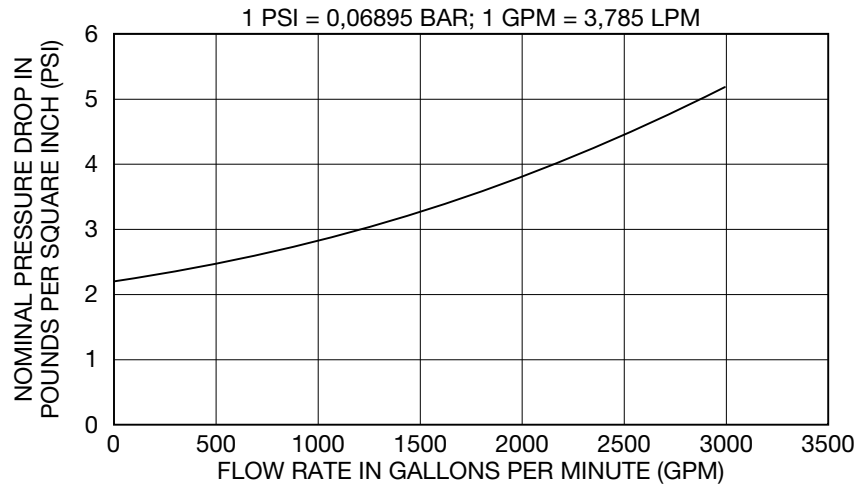

GRAPH E
8 INCH (DN200) PRV-1A PRESSURE REDUCING VALVE
MINIMUM PRESSURE DROP

Limited Warranty

For warranty terms and conditions, visit www.tyco-fire.com.

Ordering Procedure

North America Pressure Reducing Valve

Specify: Size (specify), 125 psi (8,6 bar) Outlet “Set Pressure” with (G x G, or F x F) Connection, P/N (specify):

- Valve Size
2, 3, 4, 6, or 8 in.
- 125 psi (8,6 bar) Outlet “Set Pressure” Pressure
- Connection Type - Grooved or Flanged

2 in. G x G*
2.37 in. (60,3 mm)
Groove O.D.55-001-2-020

3 in. G x G
3.50 in. (88,9 mm)
Groove O.D.55-001-2-030

4 in. G x G
4.50 in. (114,3 mm)
Groove O.D.55-001-2-040

6 in. G x G
6.62 in. (168,3 mm)
Groove O.D.55-001-2-060

8 in. G x G**
8.62 in. (219,1mm)
Groove O.D.55-001-2-080

3 in. F x F
ANSI Flange55-002-2-030

4 in. F x F
ANSI Flange55-002-2-040

6 in. F x F
ANSI Flange.55-002-2-060

8 in. F x F**
ANSI Flange55-002-2-080

* = Maximum Rate Pressure is 250 psi (17,2 bar).
** = FM only.

Pressure Relief Valve

Specify: 3/4 in. (DN20) Threaded NPT Globe Configuration, CLA-VAL Model 55L-60 Pressure Relief Valve, P/N 55L60270

Replacement Valve Parts

Specify: (description) for use with (specify) size Model PRV-1A Pressure Reducing Valve, P/N (specify, see Figures 3 and 7)

South America, Central America and Eastern Hemisphere Pressure Reducing Valve

Specify: Size (specify), 125 psi (8,6 bar) Outlet “Set Pressure” with (G x G, or F x F) Connection, for grooved valves specify outer diameter (O.D.) pipe size; for flanged valves

specify flange drilling, P/N (specify):

- Valve Size
2, 3, 4, 6, or 8 in.
- 125 psi (8,6 bar) Outlet “Set Pressure” Pressure
- Connection Type - Grooved or Flanged
- For flanged, identify flange drilling specification as follows:
ANSI B16-1 (Class 125)
ISO 7005-2 (PN16)

Note: See Table A for flange drilling dimensional specifications.

2 in. G x G*
2.37 in. (60,3 mm)
Groove O.D.55-001-2-020

3 in. G x G
3.50 in. (88,9 mm)
Groove O.D.55-001-2-030

4 in. G x G
4.50 in. (114,3 mm)
Groove O.D.55-001-2-040

6 in. G x G
6.62 in. (168,3 mm)
Groove O.D.55-001-2-060

165,1 mm G x G
Grooved55-001-2-066

8 in. G x G**
8.62 in. (219,1mm)
Groove O.D.55-001-2-080

3 in. F x F
ANSI Flange55-002-2-030

3 in. F x F
ISO (PN16) Flange55-004-2-030

4 in. F x F
ANSI Flange55-002-2-040

4 in. F x F
ISO (PN16) Flange55-004-2-040

6 in. F x F
ANSI Flange55-002-2-060

6 in. F x F
ISO (PN16) Flange55-004-2-060

8 in. F x F**
ANSI Flange55-002-2-080

8 in. F x F**
ISO (PN16) Flange55-004-2-080

* = Maximum Rate Pressure is 250 psi (17,2 bar).
** = FM only.

Pressure Relief Valve

Specify: 3/4 in. (DN20) Threaded NPT Globe Configuration, CLA-VAL Model 55L-60 Pressure Relief Valve, P/N 55L60270

Replacement Valve Parts

Specify: (description) for use with (specify) size Model PRV-1A Pressure Reducing Valve, P/N (specify, see Figures 3 and 7)



TFP1581 Change History Appendix

ISSUE DATE	NOTES
10-23	Page 10, Installation section, first Note, clarified permissible valve orientations.
05-23	Page 6, Technical Data Rated Flowing Range sub-section, 2 in., changed range to 25 to 260 gpm, formerly 25 to 250 gpm.
03-23	Page 2, Technical Data Maximum Inlet Pressure sub-section, expanded to list data for each individual valve size, 250 psi (17,2 bar) for 2 in. (DN80) size, 300 psi (20,7 bar) for all others sizes, formerly shown as 300 psi (20,7 bar) implicit for all sizes; Page 12, Graph A, 2 in. (DN80) valve size, reduced flow rate scale to maximum 250 GPM, formerly 300 GPM.
01-23	Page 1, General Description section, added statement indicating DV-5A valve is utilized in the assembly.
08-22	Page 1, updated QR code and URL; Page 14, changed corporate address and telephone number to 1467 Elmwood Avenue, Cranston, RI 02910 Telephone +1-401-781-8220, formerly 1400 Pennbrook Parkway, Lansdale, PA 19446 Telephone +1-215-362-0700.
06-22	Page 1, added QR code and URL to allow convenient access to electronic version from printed document; Added 165,1 mm size for South America, Central America and Eastern Hemisphere markets; Page 11, Table B, updated Diaphragm Chamber Cover Bolt minimum torque specifications for all valve sizes.
10-21	Updated Rated Flowing Range sub-section on page 6, changing note to Note: Rated flowing range is the flow range tested by the approval agencies. Formerly shown as Note: Rated flowing range is the flow range tested by the approval agencies. All valves are leak tight and are capable of operating at 0 gpm (0 Lpm).
08-20	Changed part number for 4 in. (DN100) valve with ISO (PN16) F x F end connections to 55-004-2-040, formerly 52-570-8-113.
06-20	Removed Flare Fitting featuring 0.125" (3,2 mm) restriction from Bill of Materials in Trim Assembly Figure 7; Removed 6.50 in. (165,1 mm) size from dimension table in Groove x Groove End Connections Figure 8.
04-20	Updated product photo.
03-20	Updated Rated Flowing Range in Technical Data section to reflect data from testing by FM Global.
02-20	Added NOTICE after Step 7 of Placing the Valve in Service, Adjusting Downstream Pressure procedure to record pressure and flow statistics on tag and attach tag to front of valve.
12-19	New Technical Data Sheet TFP1581 describes Model PRV-1A Pilot Operated Pressure Reducing Valve.