

Technical Data and Installation Instructions

for use by heating contractor

Low-loss headers

Steel chamber with supply and return connections for both boiler and system loop

For Residential and Commercial application in conjunction with Viessmann boilers



Low-Loss Headers

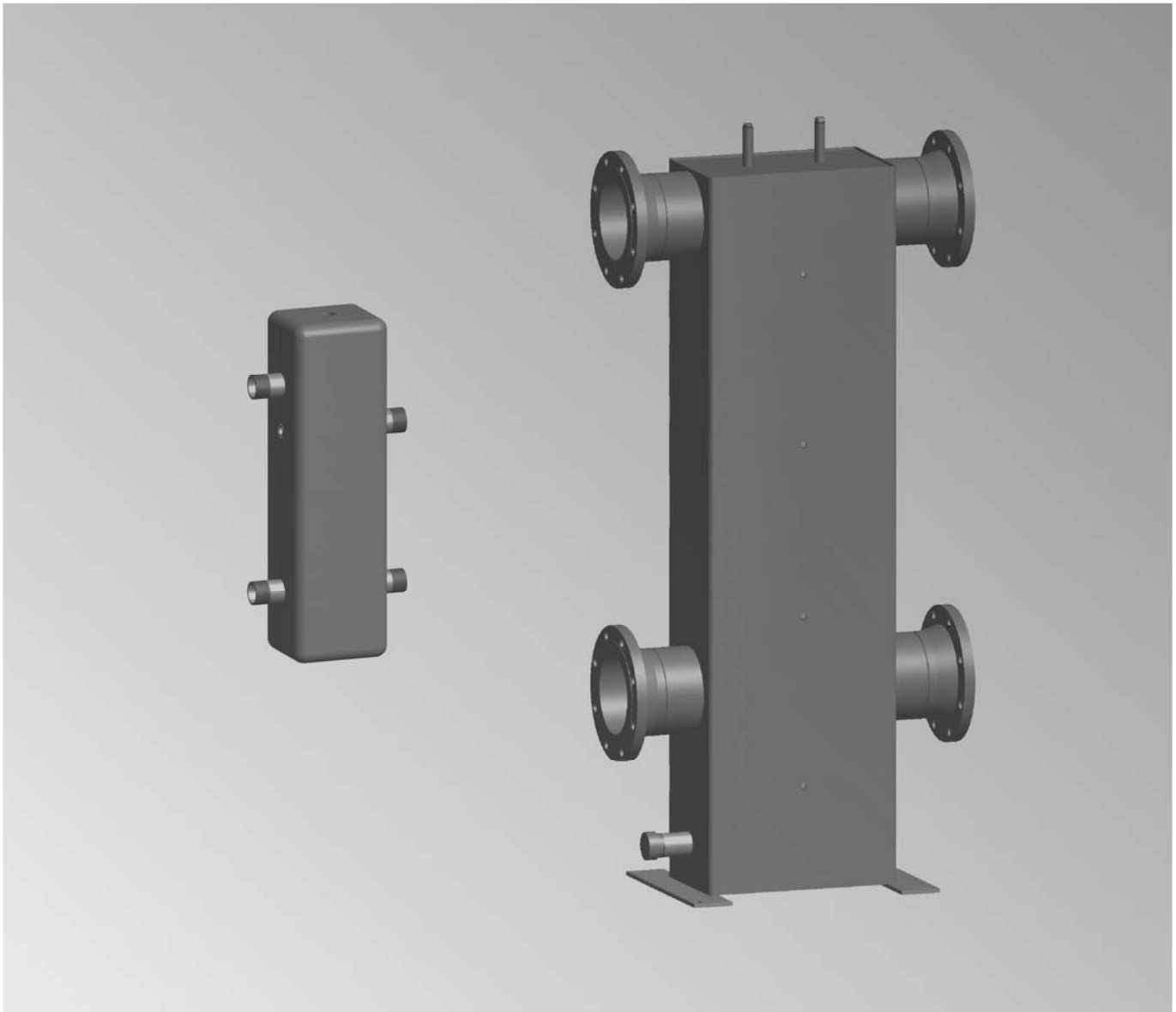

Safety, Installation and Warranty Requirements

Please ensure that these instructions are read and understood before commencing installation. Failure to comply with the instructions listed below and details printed in this manual can cause product/property damage, severe personal injury, and/or loss of life. Ensure all requirements below are understood and fulfilled (including detailed information found in manual subsections).

■ **Product documentation**

Read all applicable documentation before commencing installation. Store documentation near boiler in a readily accessible location for reference in the future by service personnel.

For a listing of applicable literature, please see section entitled "Important Regulatory and Safety Requirements".



■ **Warranty**

Information contained in this and related product documentation must be read and followed. Failure to do so renders the warranty null and void.



■ **Licensed professional heating contractor**

The installation, adjustment, service and maintenance of this equipment must be performed by a licensed professional heating contractor.

Please see section entitled Safety and "Important Regulatory and Installation Requirements".



■ **Advice to owner**

Once the installation work is complete, the heating contractor must familiarize the system operator/ultimate owner with all equipment, as well as safety precautions/requirements, shutdown procedure, and the need for professional service annually before the heating season begins.

Important Regulatory and Installation Requirements

Approvals

Viessmann boilers, burners and controls are approved for sale in North America by CSA International.

Codes

The installation of this unit shall be in accordance with local codes. In the absence of local codes, use:

- CSA C22.1 Part 1 and/or local codes in Canada
- National Electrical Code ANSI/NFPA 70 in the U.S.

Always use latest editions of codes.

The heating contractor must comply with the Standard for Controls and Safety Devices for Automatically Fired Boilers, ANSI/ASME CSD-1 where required by the authority having jurisdiction.

Working on the equipment

The installation, adjustment, service, and maintenance of this product must be done by a licensed professional heating contractor who is qualified and experienced in the installation, service, and maintenance of hot water boilers. There are no user serviceable parts on the boiler, burner, or control.

- ▶ Please carefully read this manual prior to attempting installation. Any warranty is null and void if these instructions are not followed.

For information regarding other Viessmann System Technology componentry, please reference documentation of the respective product.

We offer frequent installation and service seminars to familiarize our partners with our products. Please inquire.

- ▶ The completeness and functionality of field supplied electrical controls and components must be verified by the heating contractor. These include low water cut-offs, flow switches (if used), staging controls, pumps, motorized valves, air vents, thermostats, etc.

Safety	Safety, Installation and Warranty Requirements.....2 Product documentation.....2 Licensed professional heating contractor.....2 Advice to owner.....2 Warranty.....2 Important Regulatory and Installation Requirements.....2 Approvals.....2 Codes.....2 Working on the equipment.....2
General Information	About these Installation Instructions.....4 Product Description.....5 Principles of Operation.....6 Product Information.....7
Installation	Description (Type 80/60 and 120/80).....8 Standard equipment.....8 Low-loss header temperature sensors.....8 Insulation.....8 Dimensions (Type 80/60).....9 Dimensions (Type 120/80).....10 Installation Steps (Type 80/60 and 120/80)11 Description (Type 160/80 to 700/500).....13 Standard equipment.....13 Low-loss header temperature sensors.....13 Insulation.....13 Dimensions (Type 160/80 to 700/500).....14 Installation Steps (Type 160/80 to 700/500).....16

About these Installation Instructions

 Take note of all symbols and notations intended to draw attention to potential hazards or important product information.

WARNING

Warnings draw your attention to the presence of potential hazards or important product information.

► Indicates an imminently hazardous situation which, if not avoided, could result in death, serious injury or substantial product/property damage.

CAUTION

Cautions draw your attention to the presence of potential hazards or important product information.

► Indicates an imminently hazardous situation which, if not avoided, may result in minor injury or product / property damage.

IMPORTANT

► Helpful hints for installation, operation or maintenance which pertain to the product.



► This symbol indicates to note additional information



► This symbol indicates that other instructions must be referenced.

Product Description

Description

When used in conjunction with the Viessmann boilers, the low-loss header acts as a hydraulic break, decoupling boiler and system circuits from each other.

It is recommended to use the low-loss header in applications in which the total system flow rate exceeds the maximum boiler flow rate.

The temperature sensor well located at the top of the low-loss header ensures low return temperatures to the boilers, at all times, increasing operational efficiency.

In addition, the low-loss header helps eliminate air and debris from the heating system.

Low-loss headers

The benefits at a glance:

- To decouple high flow rate systems from the boiler loop.
- Enables constant flow through boiler.
- Avoids flow problems in secondary heating circuits.
- Promotes boiler condensation when used with condensing boilers.
- Protect boiler heat exchanger.
- Helps eliminate air, sediment, and debris from the heating system.
- Stand-by losses minimized by highly effective foamed in place or mineral wool insulation (optional accessory).
- Used as a separation point between boiler and system loop for troubleshooting purposes.

When to use a low-loss header:

- When the system flow rate exceeds the maximum boiler flow rate.
- When the boiler flow rate exceeds the maximum system flow rate (usually in multiple boiler systems with a low system Δt).

Principle of Operation

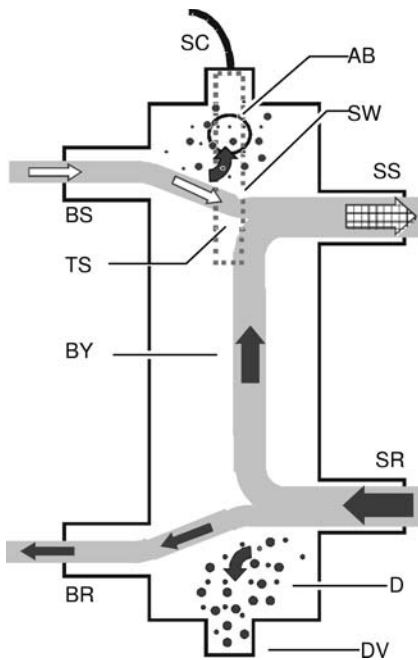

Legend

- AB Air Bleed
- BR Boiler Return
- BS Boiler Supply
- BY Bypass (with laminar flow)
- D Debris
- DV Drain Valve
- SC Sensor Cable
- SR System Return
- SS System Supply
- TS Viessmann Temperature Sensor
- SW Sensor Well

The temperature sensor connection [TS] typically located at the top of the low-loss header ensures low return temperatures to the boiler at all times and increases operational efficiency.

In addition, the low-loss header helps eliminate air and debris [D] from the heating system.

See diagram on the left for an illustration of the principle of operation.

Product may not look exactly as illustrated.

IMPORTANT

Use only a Viessmann low-loss header supplied temperature sensor to guarantee a functional system.

IMPORTANT

When installing a low-loss header, system mixed supply temperature (T3) must be calculated as follows:

$$T3 = \frac{T1 \times V_{primary} + T4 \times V_{bypass}}{V_{secondary}}$$

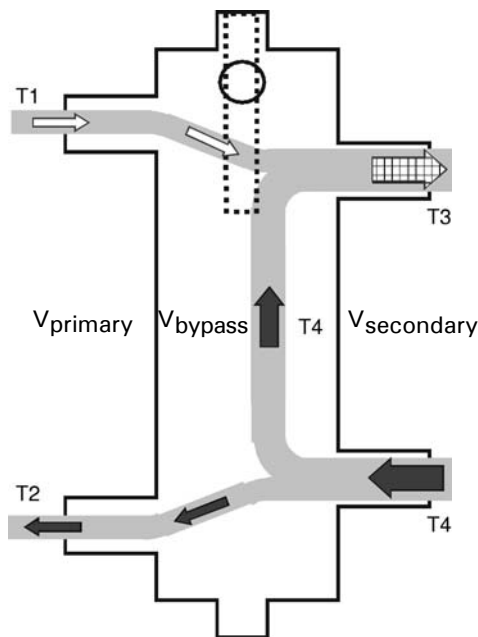

Legend

- T1 Boiler supply temperature
- T2 Boiler return temperature
- T3 System supply temperature
- T4 System return temperature
- V_{primary} Boiler circuit flow rate
- V_{secondary} Heating circuit flow rate
- V_{bypass} Bypass flow rate
- Q_{primary} Heat supplied by boiler
- Q_{secondary} Heat consumed by system

V_{primary} < V_{secondary}

T1 > T3

T2 = T4

Q_{primary} = Q_{secondary}

T1 [167°F (75°C)

V_{secondary} = V_{primary} + V_{bypass}

Product Information

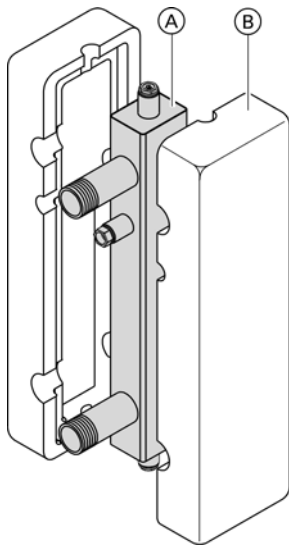

Legend

- Ⓐ Low-loss header 80/60 or 120/80
- Ⓑ Insulation (included)

IMPORTANT

For all multi-Vitodens installations using a low-loss distribution manifold, refer to the low-loss header information in the multiple-boiler low-loss distribution manifold installation instructions.

The low-loss header is available in the following sizes. Select the size based on the maximum system flow rate of your application.

LLH Model No.	Maximum system flow rate GPM (L/min)
80/60	19.5 (74)
120/80	35.2 (133)

Note: Refer to the specific application guide in the boiler technical data manual.

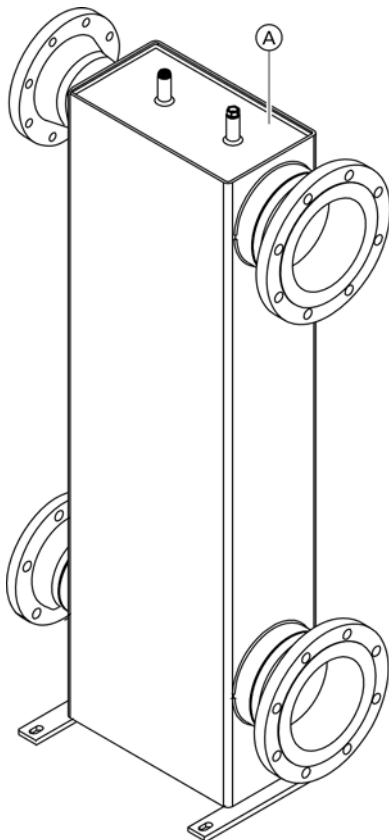

Legend

- Ⓐ Low-loss header 160/80 through to 700/500
- Ⓑ Insulation not shown (optional)

The low-loss header is available in the following sizes. Select the size based on the maximum system flow rate of your application.

LLH Model No.	Maximum system flow rate GPM (L/min)
160/80	44 (167)
200/120	80 (303)
250/150	119 (450)
300/200	189 (715)
400/200	251 (950)
450/250	374 (1416)
500/300	484 (1832)
600/400	748 (2831)
650/450	1034 (3914)
700/500	1320 (4997)

Note: Contact your Viessmann representative for multi-boiler and commercial product applications.

Description (Type 80/60 and 120/80)

Standard equipment

Model 80/60 and 120/80:

- Sensor well tapping, 1/2 in. (c/w sensor well)
- Air bleed tapping, 1/2 in. (c/w bleed valve)
- Drain/flush tapping, 1/2 in. plug
- NPT threaded connections
- Insulation

Low-loss header temperature sensors

Note: No temperature sensor is used with the Vitodens 100 boiler. Temperature sensor for all other boilers must be purchased separately (if required - optional accessory).

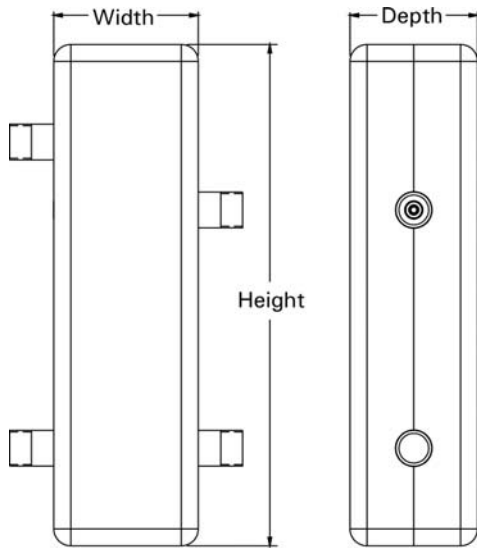

Low-loss header 80/60 and 120/80 (with insulation)

Insulation

IMPORTANT

If the standard low-loss header insulation is being installed, add extra clearance between the back of the low loss header and the finished wall.

Insulation dimensions

Model #	Depth in. (mm)	Width in. (mm)	Height in. (mm)
80/60	5 3/8 (135)	6 (155)	22 5/8 (575)
120/80	7 1/4 (183)	8 3/4 (223)	35 5/8 (905)

Dimensions (Type 80/60)

Low-loss header dimensions

Overall depth	2 1/4 in. (60 mm)
Overall width	10 3/4 in. (274 mm)
Overall height	23 in. (586 mm)
Weight (dry)	15.4 lb (7 kg)
Volume	0.5 USG (2 L)

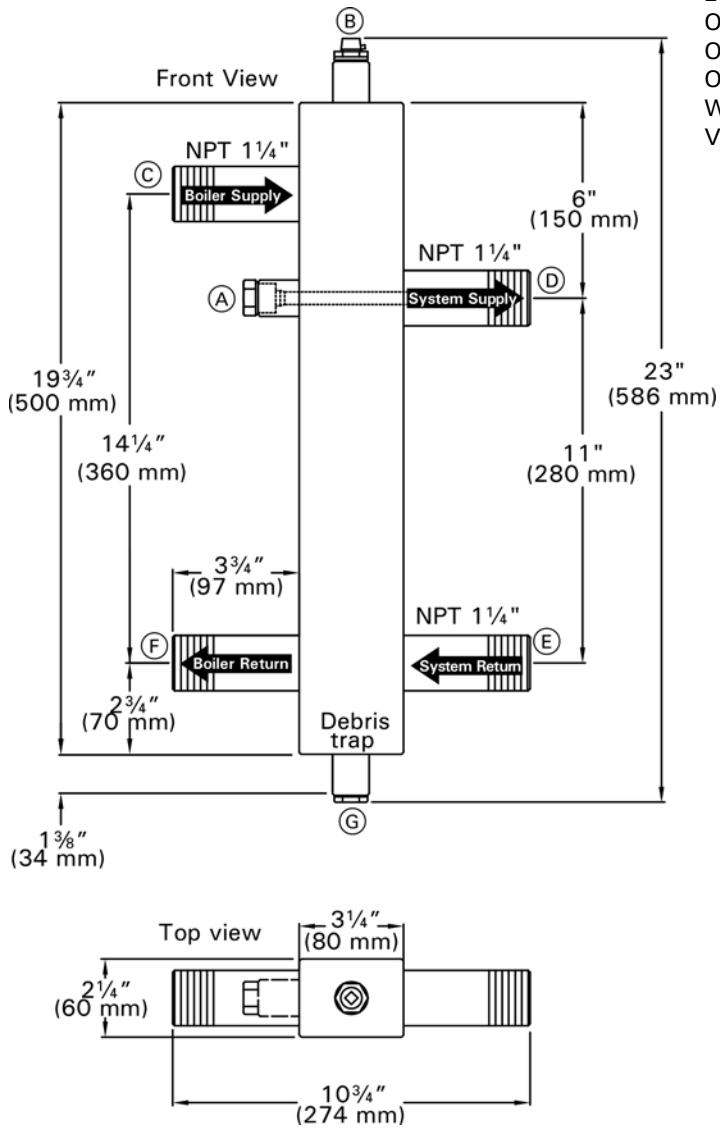

Legend

- (A) Sensor well, 150 mm
- (B) Air bleed plug
- (C) Boiler supply
- (D) System supply
- (E) System return
- (F) Boiler return
- (G) 1/2 in. drain plug

Dimensions (Type 120/80)

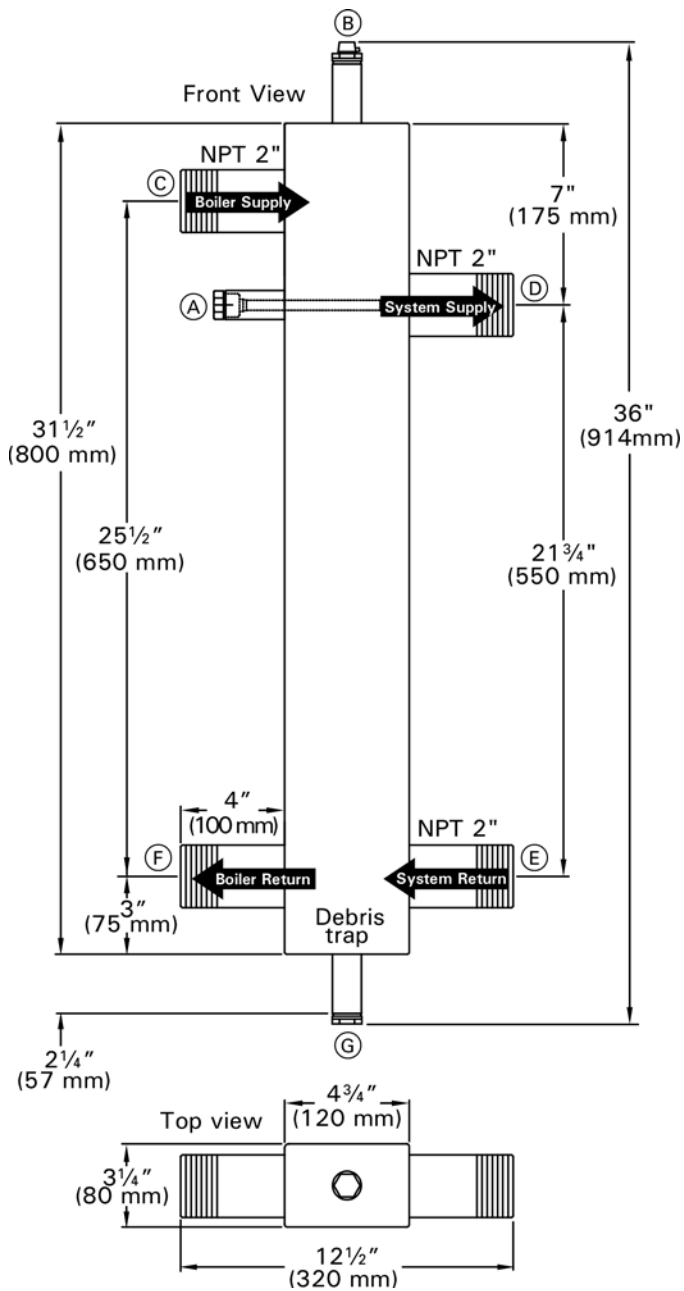

Low-loss header dimensions

Overall depth	3 1/4 in. (80 mm)
Overall width	12 1/2 in. (320 mm)
Overall height	36 in. (914 mm)
Weight (dry)	28.6 lb (13 kg)
Volume	2 USG (7.6 L)

Legend

- (A) Sensor well, 200 mm
- (B) Air bleed plug
- (C) Boiler supply
- (D) System supply
- (E) System return
- (F) Boiler return
- (G) 1/2 in. drain plug

Installation Steps (Type 80/60 and 120/80)

Before commencing with the installation of the low-loss header, check low-loss header orientation with respect to your heating system.

If (when holding the low-loss header with the sensor well connection facing to the left, as shown below).....

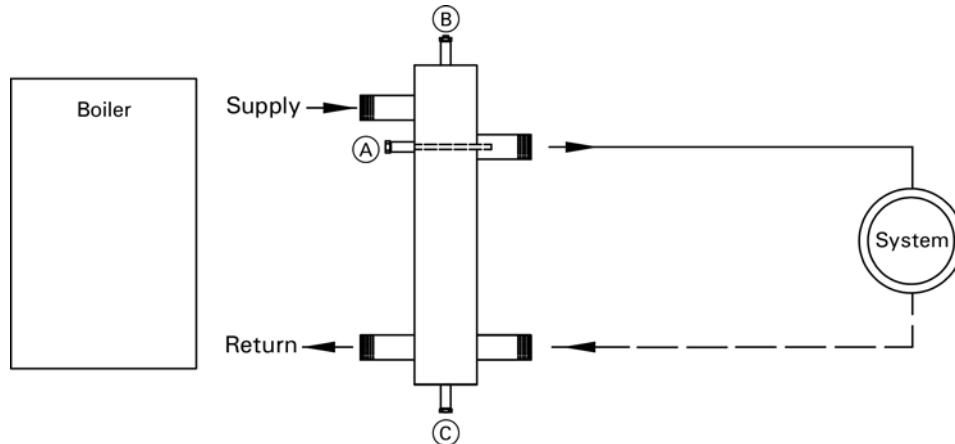

- the boiler is located to the left of the low-loss header and the heating system is located to the right, install the low-loss header as shown above (with sensor well (A) located on left side), following the installation steps on the following page.
- the boiler is located to the right of the low-loss header and the heating system on the opposite side, perform the following steps:
 1. Position the low-loss header, as shown below (with the sensor well facing the boiler).

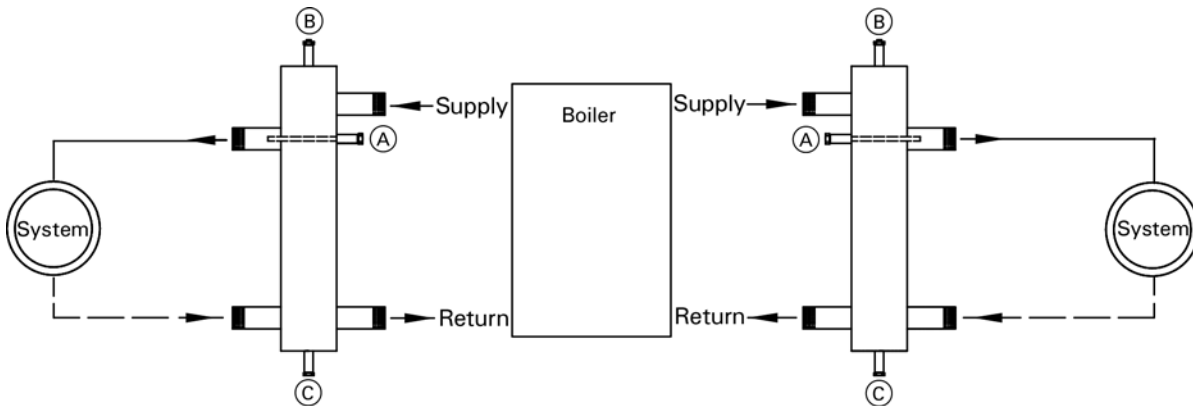

2. Proceed with the installation steps on the following pages (depending on low-loss header model).

- (A) Sensor well
- (B) Air bleed opening
- (C) ½ in. drain plug

Note: Refer to boiler Installation Instructions for boiler pump installation location.

Installation Steps (Type 80/60 and 120/80) (continued)

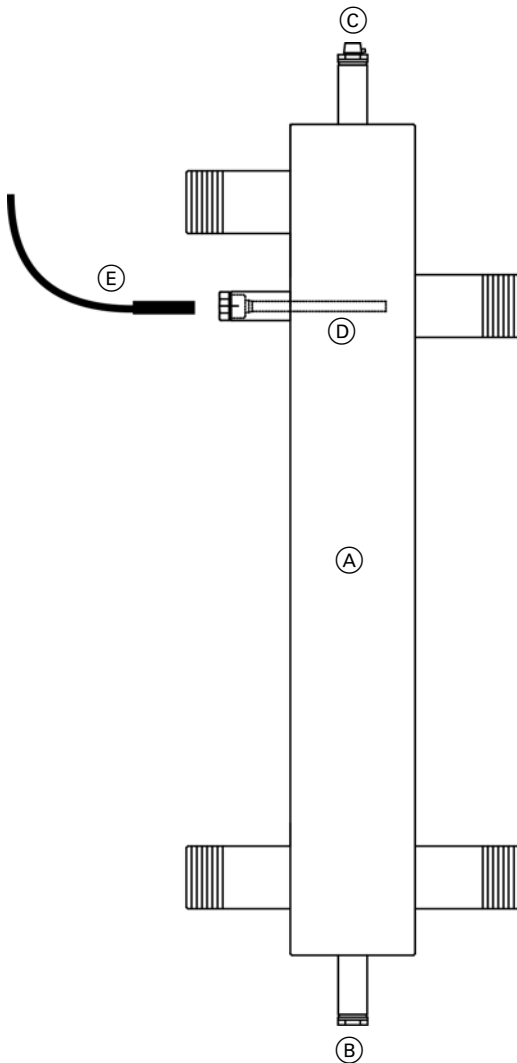

1. Remove low-loss header and supplied accessories from carton (see section entitled "Standard Equipment" on pages 8 and 13 for a list of component parts included with your low-loss header).
2. Drain plug (B), air bleed plug (C) (c/w O-ring) and sensor well (D) are pre-installed. Ensure tightness and check for leaks.
3. Tighten all connections.
4. Install low-loss header only in vertical position (as shown). See pages 6, indicating system and boiler connection sides. Make system and boiler connections accordingly.
5. Insert temperature sensor (E) probe end fully into sensor well (D) (if supplied). Refer to the boiler installation/service instructions for sensor connections.

Legend

- (A) Low-loss header
- (B) Drain plug
- (C) Air bleed plug
- (D) Sensor well
- (E) Temperature sensor (optional) Refer to the boiler installation instructions for application.

Description (Type 160/80 to 700/500)

Standard equipment

Model 160/80 to 700/500:

- Sensor well tapping, ½ in. or Air bleed tapping, ½ in.
- Air bleed tapping, ½ in.
- Drain/flush tapping, 2 in.
- ANSI flanges welded on
- Insulation (optional - accessory)

Low-loss header temperature sensors

Note: Temperature sensor for boilers must be purchased separately (if required). Refer to the boiler and/or control installation instructions for more information. For multi-boiler installations a common supply sensor is supplied with the Viessmann cascade control (Vitocontrol-S/Vitotronic 300-K).

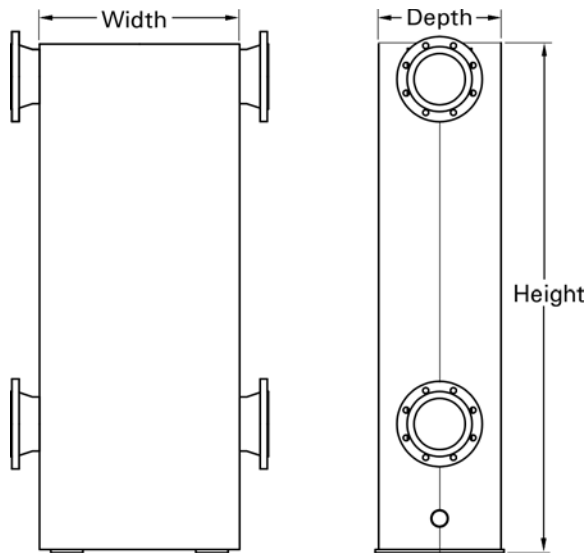

Low-loss header 160/80 to 700/500
(with insulation - optional accessory)

Insulation

IMPORTANT

If the low-loss header insulation is being installed, add extra clearance between the back of the low loss header and the finished wall.

Insulation dimensions

Model #	Depth in. (mm)	Width in. (mm)	Height in. (mm)
160/80	11 (280)	22½ (560)	56¾ (1440)
200/120	12⅝ (320)	23¾ (600)	57 (1450)
250/150	13¾ (350)	25⅝ (650)	57¾ (1468)
300/200	15¾ (400)	27⅝ (700)	58¼ (1481)
400/200	15¾ (400)	31½ (800)	58⅞ (1495)
450/250	17¾ (450)	33½ (850)	59¾ (1520)
500/300	19¾ (500)	35½ (900)	71⅝ (1819)
600/400	23⅝ (600)	39⅝ (1000)	72⅝ (1845)
650/450	25⅝ (650)	41⅝ (1050)	76⅝ (1945)
700/500	27⅝ (700)	43⅝ (1100)	90¼ (2291)

Dimensions (Type 160/80 to 700/500)

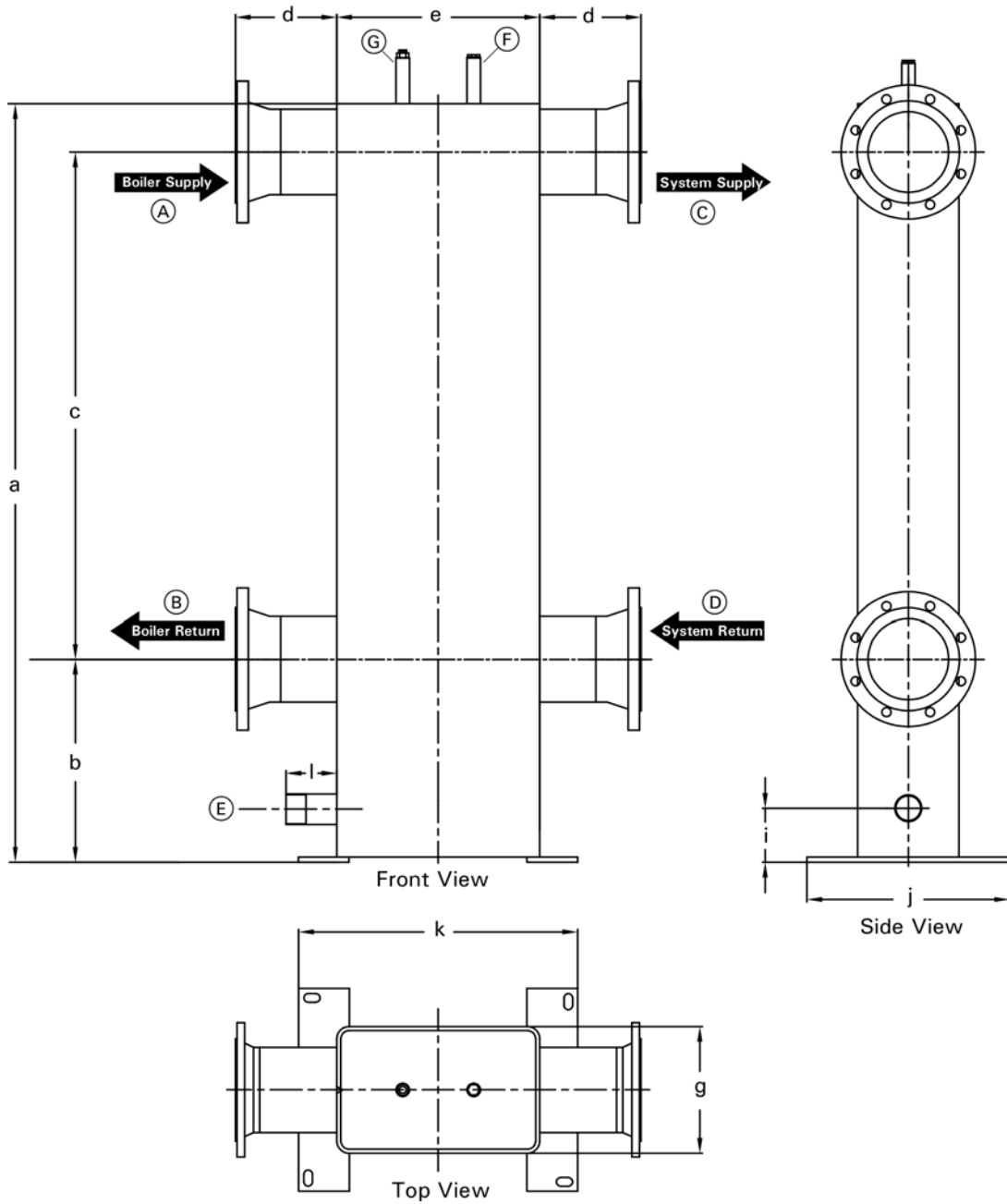

Legend

- (A) Boiler supply
- (B) Boiler return
- (C) System supply
- (D) System return
- (E) Drain/clean-out opening
- (F) Sensor well (system side)
- (G) Air vent (boiler side)

Dimensions (Type 160/80 to 700/500) (continued)

		Low-loss Header Model									
Dimension		160/80	200/120	250/150	300/200	400/200	450/250	500/300	600/400	650/450	700/500
a	in. (mm)	56.7 (1440)	57 (1450)	57.8 (1468)	58.3 (1481)	58.9 (1495)	59.8 (1520)	71.6 (1820)	72.4 (1840)	76.6 (1945)	90.2 (2290)
b	in. (mm)	15.3 (390)	15.3 (390)	15.7 (400)	15.7 (400)	15.7 (400)	15.7 (400)	19.7 (500)	19.7 (500)	22.4 (570)	23.6 (600)
c	in. (mm)	39.4 (1000)	39.4 (1000)	39.4 (1000)	39.4 (1000)	39.4 (1000)	39.4 (1000)	47.2 (1200)	47.2 (1200)	47.2 (1200)	59 (1500)
d	in. (mm)	7.9 (200)	7.9 (200)	7.9 (200)	7.9 (200)	7.9 (200)	7.9 (200)	7.9 (200)	7.9 (200)	7.9 (200)	7.9 (200)
e	in. (mm)	6.3 (160)	7.9 (200)	9.8 (250)	11.8 (300)	15.7 (400)	17.7 (450)	19.7 (500)	23.6 (600)	25.6 (650)	27.6 (700)
g	in. (mm)	3.1 (80)	4.7 (120)	5.9 (150)	7.9 (200)	7.9 (200)	9.8 (250)	11.8 (300)	15.7 (400)	17.7 (450)	19.7 (500)
i	in. (mm)	3.8 (97)	3.8 (97)	4.2 (107)	4.2 (107)	4.2 (107)	4.2 (107)	4.2 (105)	4.2 (105)	4.2 (105)	4.2 (105)
j	in. (mm)	11 (280)	12.6 (320)	13.8 (350)	15.7 (400)	15.7 (400)	17.7 (450)	19.7 (500)	23.6 (600)	25.6 (650)	27.6 (700)
k	in. (mm)	12.2 (310)	13.8 (350)	15.7 (400)	17.7 (450)	21.7 (550)	23.6 (600)	25.6 (650)	29.5 (750)	31.5 (800)	33.5 (850)
l	in. (mm)	4 (100)	4 (100)	4 (100)	4 (100)	4 (100)	4 (100)	6.3 (160)	6.3 (160)	6.3 (160)	6.3 (160)
Flange		ANSI 2½ in.	ANSI 3 in.	ANSI 4 in.	ANSI 5 in.	ANSI 6 in.	ANSI 8 in.	ANSI 8 in.	ANSI 10 in.	ANSI 12" in.	ANSI 14 in.
Weight (Dry)	lb. (kg)	72.6 (33)	136.4 (62)	193.6 (88)	211.2 (96)	316.8 (144)	387.2 (176)	624.8 (284)	822.8 (374)	1170.4 (532)	1504.8 (684)
Volume	USG (L)	4.9 (18.8)	9.3 (35.2)	14.5 (55.1)	23.2 (88.2)	54.0 (118.7)	46.6 (177.1)	62.2 (236.2)	119.4 (453.6)	155.0 (589.1)	222.4 (845.2)

Installation Steps (Type 160/80 to 700/500)

Before commencing with the installation of the low-loss header, check low-loss header orientation with respect to your heating system.

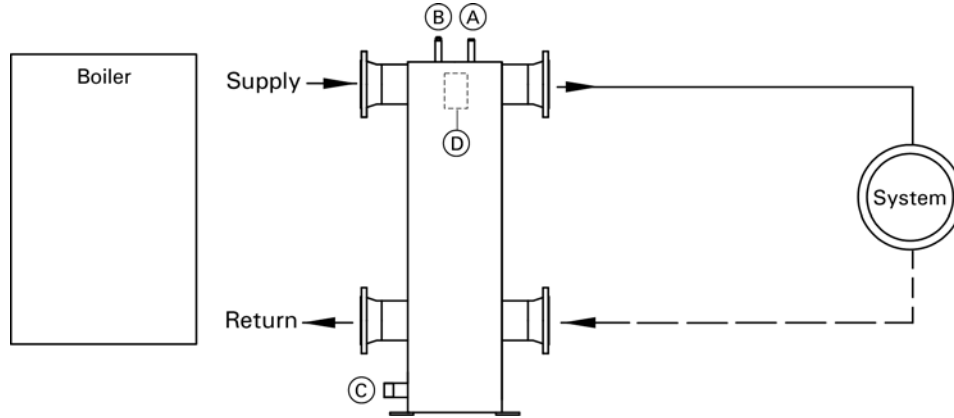

1. Position the low-loss header, as shown below (with the drain plug facing the boiler).

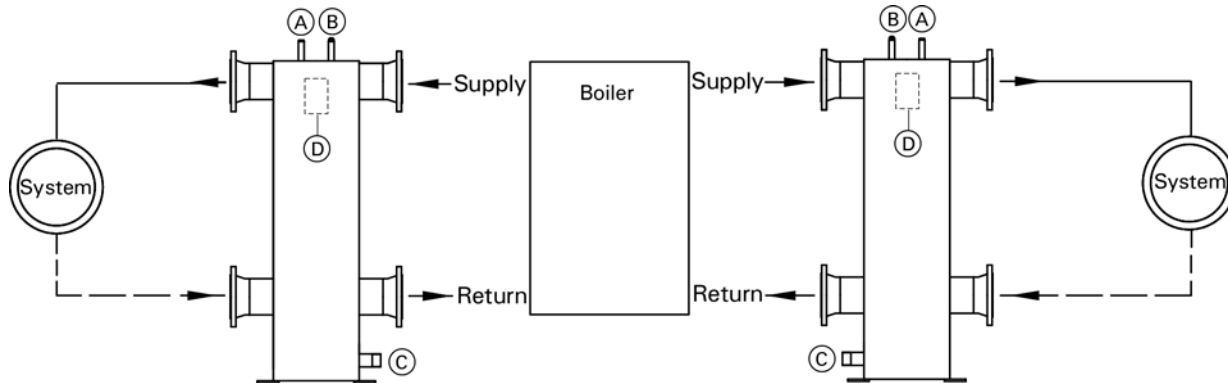

2. Proceed with the installation steps on the following pages.

Legend

- (A) Sensor well
- (B) Air bleed opening
- (C) Drain tapping 2 in. NPT
- (D) Low-loss header label

Note: Refer to boiler Installation Instructions for boiler pump installation location.

Installation Steps (Type 160/80 to 700/500) (continued)

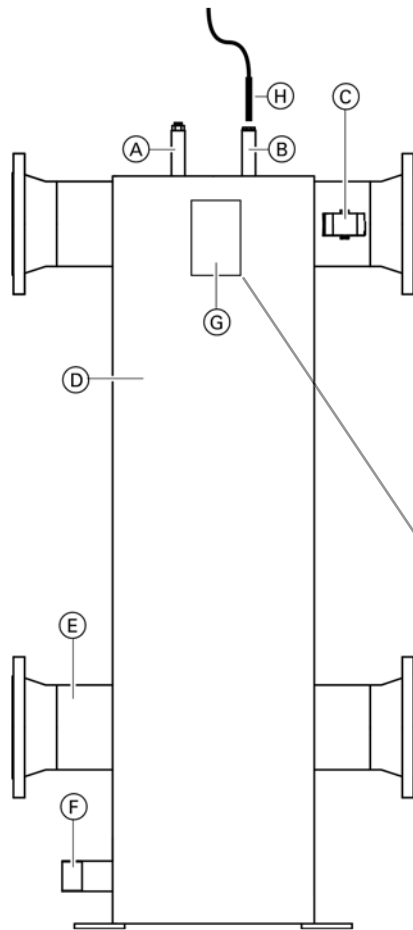

1. Before commencing with the installation, plan the location and orientation of the low-loss header. Take the following into consideration...
 - The sensor well is installed on the system side of the low-loss header. The low-loss header can be rotated as required.
 - Ensure that the drain connection is not pointing towards the wall.
 - Low-loss header must be installed in vertical position.
2. Fasten low-loss header to floor with anchor bolts (field supplied), using anchor holes provided. Solid flooring such as concrete is required when floor-mounting the low-loss header.
3. Complete piping as required (ANSI counter flanges, gaskets and bolts (field supplied).
4. Tighten all connections.
5. Install and connect common supply temperature sensor.

Legend

- (A) Air vent
- (B) Common supply temperature sensor well (immersion sensor)*
- (C) Common supply temperature sensor (strap-on sensor)*
- (D) Low-loss header
- (E) Flange of low-loss header, ANSI standard
- (F) Drain connection, 2 in. NPT male
- (G) Low-loss header label
- (H) Common supply low-loss header temperature sensor (immersion type)

* Immersion or strap-on sensor depending on application and boiler/control models.

Note: All counter flanges shall be ANSI standard (field supplied).

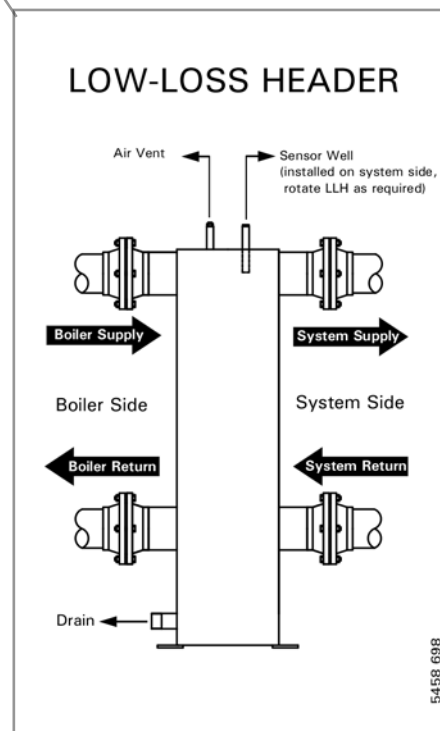



Printed on environmentally friendly
(recycled and recyclable) paper.



Technical information subject to change without notice.

Viessmann Manufacturing Company Inc.
750 McMurray Road
Waterloo, Ontario • N2V 2G5 • Canada
TechInfo Line 1-888-484-8643
1-800-387-7373 • Fax (519) 885-0887
www.viessmann.ca • info@viessmann.ca

Viessmann Manufacturing Company (U.S.) Inc.
45 Access Road
Warwick, Rhode Island • 02886 • USA
TechInfo Line 1-888-484-8643
1-800-288-0667 • Fax (401) 732-0590
www.viessmann-us.com • info@viessmann-us.com