



NSF/ANSI 61

WHERE QUALITY COMES FIRST

ZEP-1 Stainless Steel Expansion Tank

and Shock Arrester for Tankless and POU Water Heaters with 2 gallons or less of total water volume

ZEP-1 was designed to provide maximum protection to the heat exchanger and the piping system on tankless water heaters, relieving problems associated with excess pressure by absorbing any potential increase in pressure within the unit or piping system; this helps prevent potentially costly leaks and repairs.



unique features:

- Tank has a 50 PSI factory precharge
- Air charge can be adjusted, and is serviceable
- Entire tank is constructed of 304 stainless steel
- 1/2" NPTM 304 stainless steel connection
- UV resistant and approved for outdoor installation
- Butyl membrane diaphragm
- NSF61 Certified

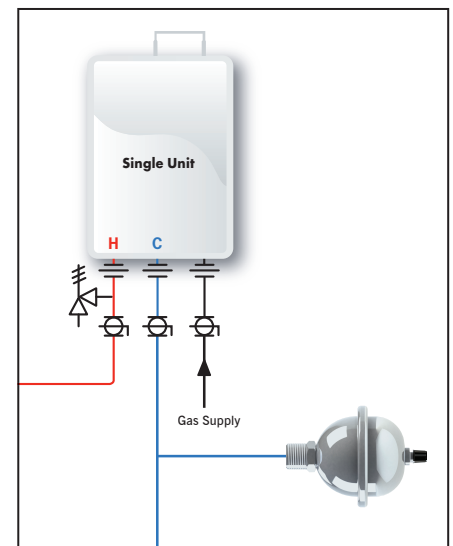

ZEP-1 can be installed below the isolation kit or anywhere on the cold water supply line between the heater and the check valve.

technical and dimensional data

Model	Connection	O Diameter	H height
	NPT	inches	inches
ZEP-1	1/2"	3.2	2.8

operating conditions

maximum working pressure	150 psi
maximum operating temperature	140°F



North American Headquarters Zilmet USA
 240 Commerce Park Road,
 North Kingstown, RI 02852
 401-884-4943
 info@zilmetusa.com
 www.zilmetusa.com

Headquarters
 Via del Santo, 242 - 35010 Limena (PD) -
 Italy Tel. +39 049 7664901 • Fax +39
 049 767321
 www.zilmet.it
 zilmet@zilmet.it

Production plants - Italy
 Limena (PD) Via del Santo, 242
 Via Visco, 2 • Via Colpi, 30
 Via Tamburin, 15/17
 Bagnoli di Sopra (PD) - Via V Strada,
 21/23

Branches
 Zilmet Deutschland
 GmbH www.zilmet.de
 Zilmet USA
 www.zilmetusa.com
 Zilmet UK
 www.zilmet.co.uk