

INSTALLATION GUIDE

GB-500 100 GPM Great Basin™ Indoor/Outdoor Grease Interceptor

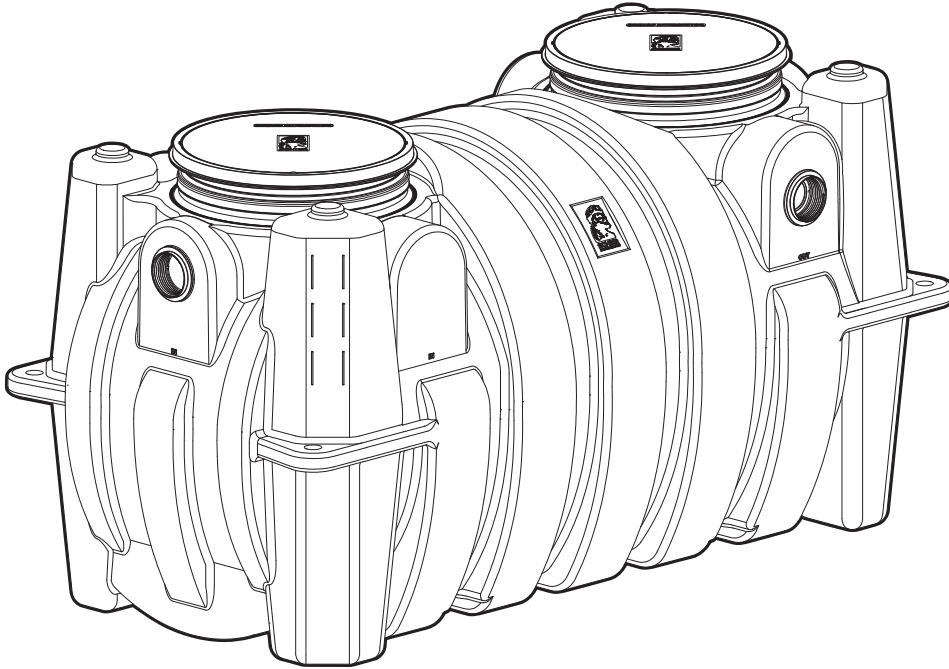

Contents

Special Precautions	2-3
Getting to Know the GB-500	4
Installation	5-11
Series Installations	12



SCHIER

LIFETIME GUARANTEED **GREASE INTERCEPTORS**

913-951-3300 | schierproducts.com
© Copyright 2023 Schier Products Company, 01/01/23



SPECIAL PRECAUTIONS

For Schier Grease Interceptor Installations - Failure to follow this guidance voids your warranty

WARNING! DO NOT AIR TEST UNIT OR RISER SYSTEM!
Doing so may result in property damage, personal injury or death.

CAUTION! Do not install this unit in any manner except as described in these instructions.

Installation Instructions

Installation instructions and additional components are included with the interceptor. Read all instructions prior to installation. This interceptor is intended to be installed by a licensed plumber in conformance with all local codes.

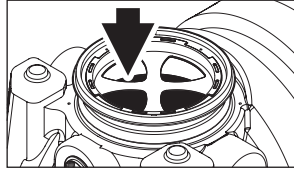

Install interceptor as close as possible to fixtures being served

Provide at least 16" clearance above unit for routine maintenance.

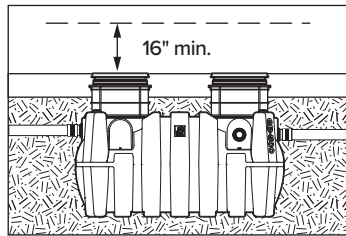

High Temperature Kitchen Water

If water is entering the interceptor at excessive temperature (over 150° F), a drain water tempering valve (DTV) and approved backflow prevention assembly must be installed. Most state and local plumbing codes prohibit water above 150° F being discharged into the sanitary sewer. Water above 150° F will weaken or deform PVC Schedule 40 pipe, poly drainage fixtures like interceptors and erode the coating of cast iron (leading to eventual failure).

ODOR ALERT!

Interceptor is not a sewer gas trap. All upstream fixtures must be trapped

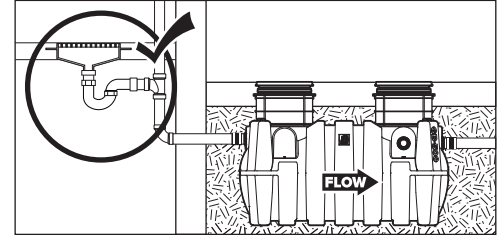

ODOR ALERT!

Do not install air gap on outlet side of interceptor.

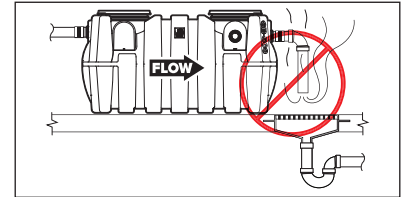

Fully Support Base of Unit

Install unit on solid, level surface in contact with the entire footprint of unit base

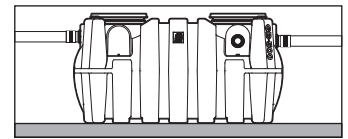

Support Inlet and Outlet Piping

For above grade installations ensure heavy inlet and outlet piping (such as cast iron or long runs) is properly supported or suspended during the entire installation process to prevent connection failure or damage to bulkhead fittings.

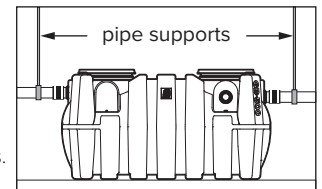

Above Grade Installation Support

The wet weight of the interceptor combined with high temperature kitchen water creates the potential for tank deformation when installed above grade. Model GB-500 installed above grade must be installed with Above Grade Support Kit model AGS2 to maintain structural integrity.

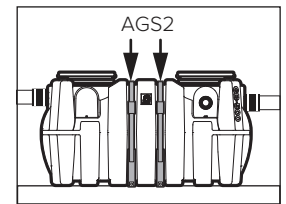

DO NOT USE CAST IRON COVERS IN ABOVE GRADE OR INDOOR INSTALLATIONS

Use composite cover C24BC for above grade installations

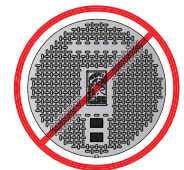



SPECIAL PRECAUTIONS

For Schier Grease Interceptor Installations - Failure to follow this guidance voids your warranty

Secure Cover Adapters

Cover adapters must be secured to base units in above grade installations with increased head pressure conditions. Use cover adapter tie-downs included with Above Grade Support Kit model AGS2.

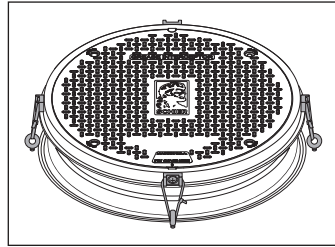

High Water Table Installations

Interceptors and risers are not designed to withstand water table height in excess of the top of the unit when buried (see figure). If it is possible for this to occur, install the interceptor and risers in a water-tight concrete vault or backfill with concrete or flowable fill (wet concrete and flowable backfill should be poured in stages to avoid crushing the interceptor). At risk areas include but are not limited to tidal surge areas, floodplains and areas that receive storm water. Great Basin™ models that are direct buried in high water table scenarios must be installed with an anchor kit. Model GB-500 uses either two model AK1 anchor kits or one AK2 anchor kit.

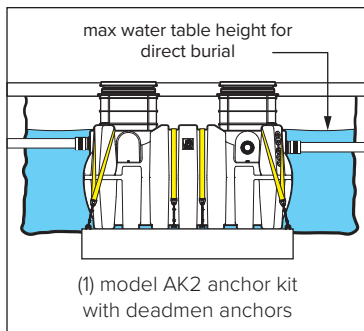
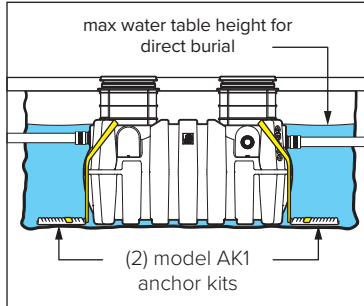

Hydrostatic/Pressure Slabs

When installed under a hydrostatic slab (slab designed to withstand upward lift, usually caused by hydrostatic pressure) interceptor must be enclosed in a watertight concrete vault.

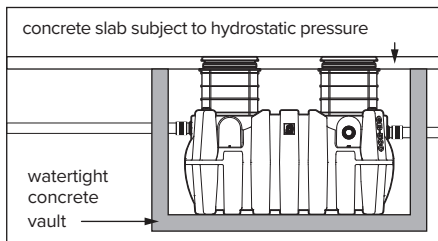

Below Grade Installation Slab Requirements

A concrete slab to finished grade with rebar is required when installing interceptor below grade.

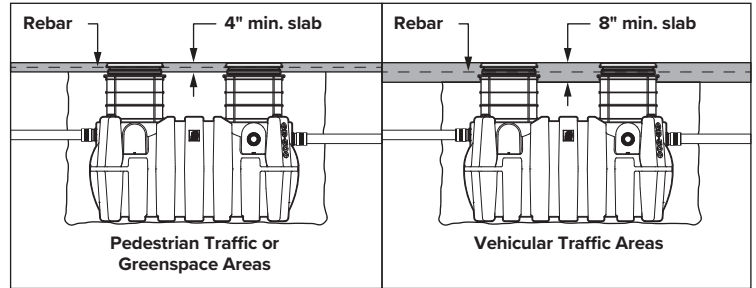

Installations with Risers

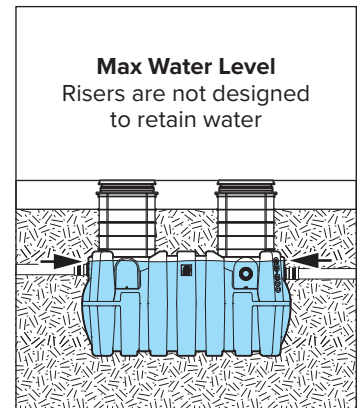
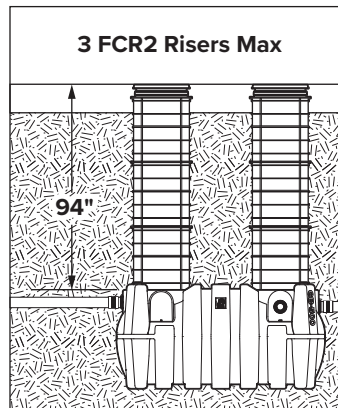

Corrugated Riser Pipe Requirements

Riser adapter model CA2 must be used when installing interceptors using 24" diameter corrugated pipe as a riser. This will adequately embed the cover adapter in the concrete slab, preventing cover/cover adapter failure under traffic rated loads.

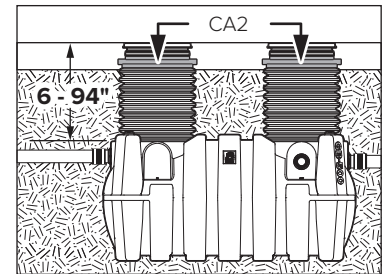

DO NOT COMPACT BACKFILL MECHANICALLY

Compact by hand only



GETTING TO KNOW THE GB-500

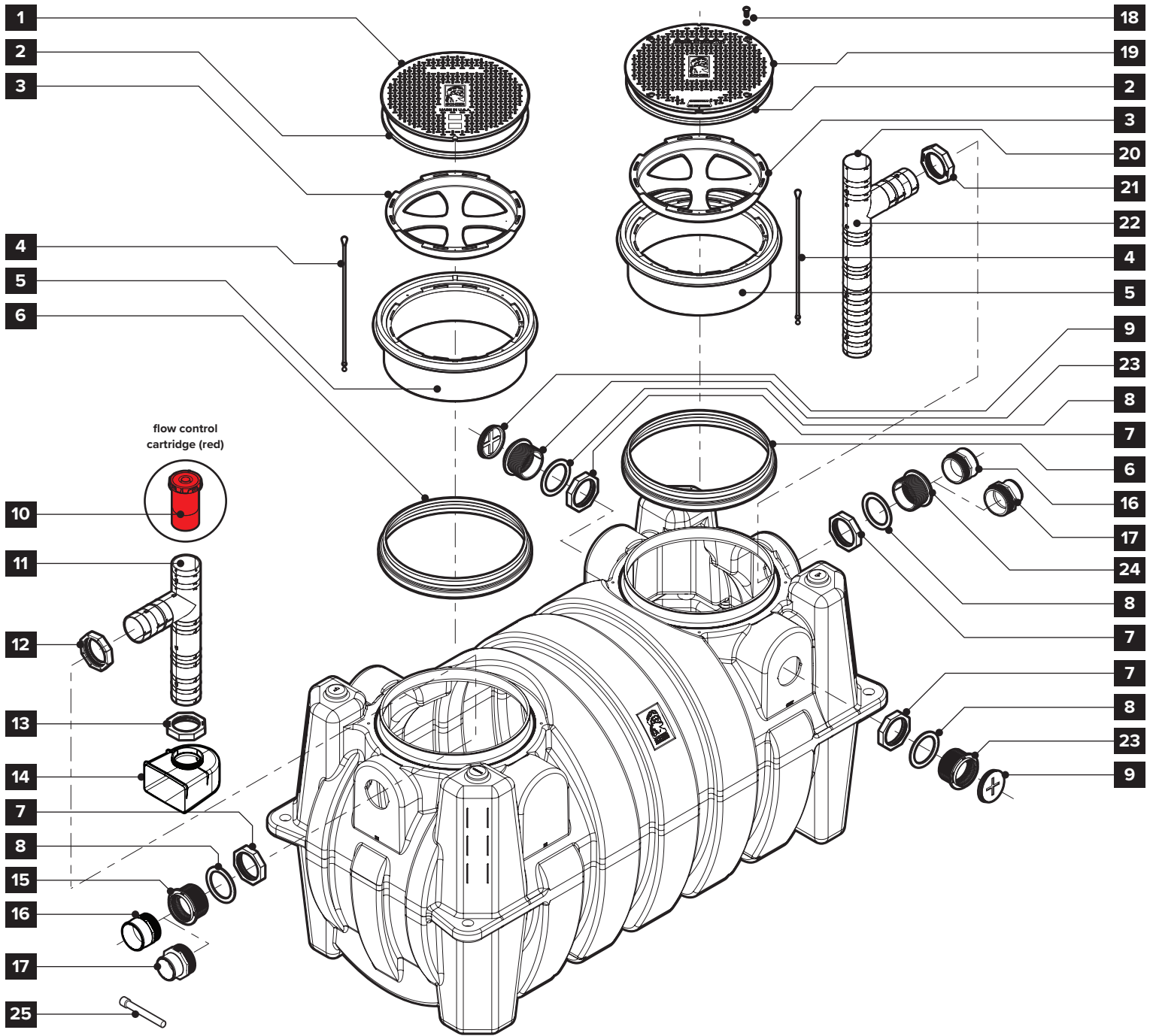

- | | | |
|---|--|--|
| <ul style="list-style-type: none"> 1. Pickable cast iron cover (standard) 2. Cover gasket 3. Safety Star® access restrictor (x2) 4. Safety Star® tether (x2) 5. Cover adapter (x2) 6. Cover adapter gasket assembly(x2) with upper and lower stainless steel band clamps 7. Bulkhead connection retaining nut 8. Bulkhead connection gasket 9. 4" cleanout plug (x2) | <ul style="list-style-type: none"> 10. Flow control cartridge (for >13' below kitchen, 200 GPM only), see page 7 for more information. 11. Inlet diffuser 12. Inlet diffuser retaining nut 13. Inlet diffuser foot retaining nut 14. Inlet diffuser (foot) 15. Inlet bulkhead connection (standard) 4" FPT 16. 4" plain end fitting (x2) 17. 3" plain end fitting (x2) (optional) | <ul style="list-style-type: none"> 18. Composite cover bolts and washers (x8) 19. Bolted composite cover (optional) 20. Air relief/visual access 21. Outlet diffuser retaining nut 22. Outlet diffuser 23. Outlet bulkhead connection (optional) 4" FPT (x2) 24. Outlet bulkhead connection (standard) 4" FPT 25. 7/16" nut driver bit |
|---|--|--|

1 Test Tank for Water Tightness

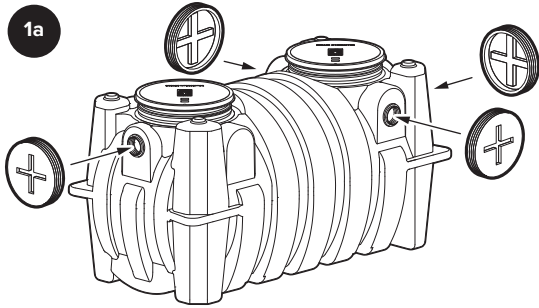

Cap all connection points with 4" cleanout plugs using pipe thread sealant or tape approved for use with plastics.

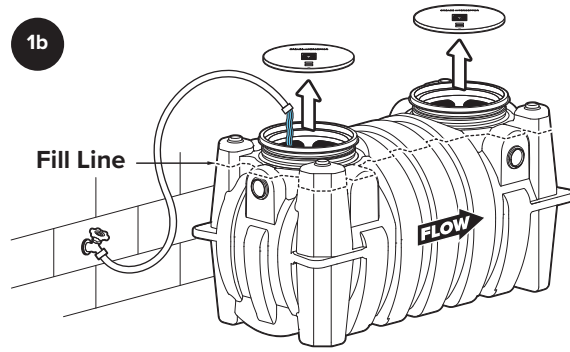

Remove covers. For base unit testing fill with water to just above the highest connection.

Inspect unit, connections and gaskets for leaks. Check water level at specific time intervals per local code.

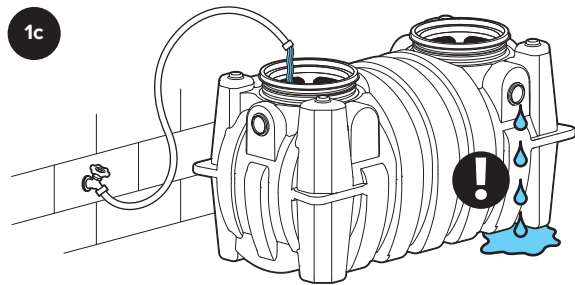

Have a Leak?

Call customer care at 913-951-3300

Hours 8am-5pm CST, M-F

2 Excavate Burial Pit ONLY

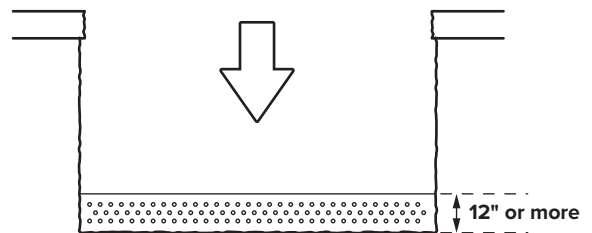
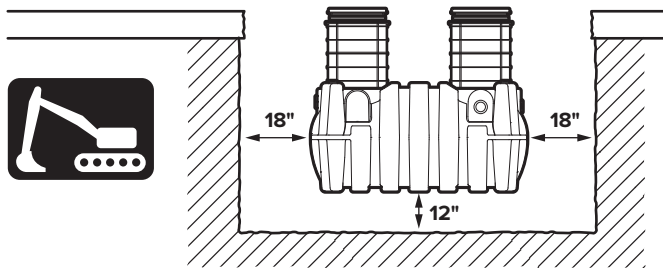

Excavate hole at least 18" larger than interceptor on all sides and 12" deeper than tank bottom. Lay a level bed of well-packed, crushed aggregate (approximately 3/4" size rock or sand, with no fines) in the base of hole.

3 Set Up Outlet Diffuser and Install Cleanout Plugs

3a Choose outlet location.

Side Outlet:

Go to Step 3b.

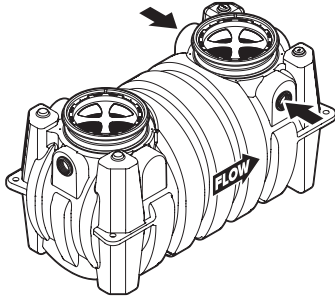

OR

Straight Through:

Go to Step 3c.

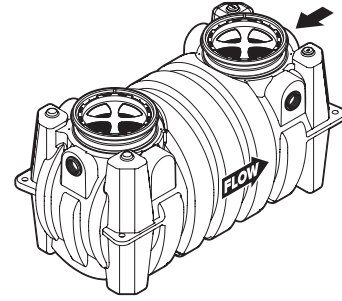

3b Reposition outlet diffuser (side outlets only)

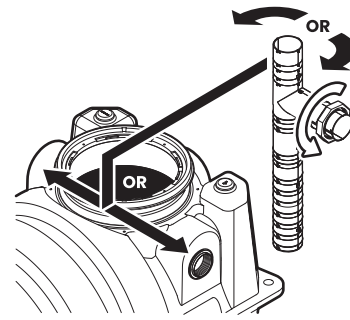
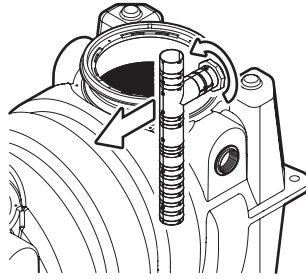
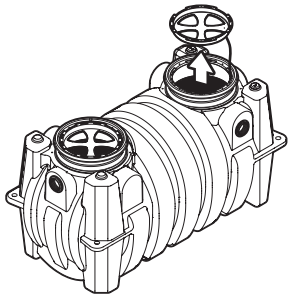

Remove safety star insert, leave tethered to unit. Unscrew diffuser retaining nut and remove outlet diffuser. Rotate diffuser toward chosen outlet, insert and hand tighten retaining nut.

3c Cap unused connections (all configurations)

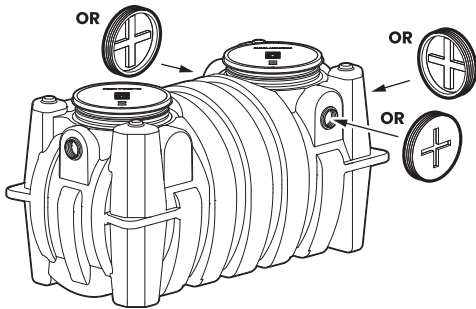

Screw in provided 4" cleanout plugs using pipe thread sealant or tape approved for use with plastics. **Do not cap the inlet or outlet connections attached to the diffusers.**

4 Install Inlet Diffuser Components

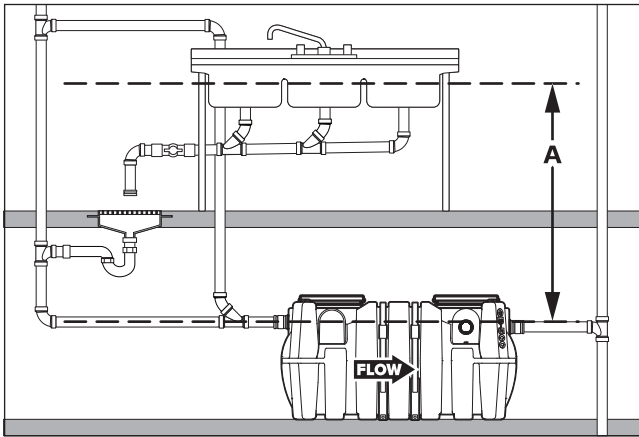

Note to Plumbing Inspector

This interceptor includes certified internal flow control and does not require a dedicated "Flow Control Vent" (air intake).

Flow control is not pre-installed on this unit.

- If dimension "A" is 13 feet or less no flow control is needed, **go to Step 5, Connect Piping.**
- If dimension "A" is more than 13 feet, or a high flow/increased head pressure condition exists, **follow Steps below.**

4a Install flow control

Unit with 4" Diffusers

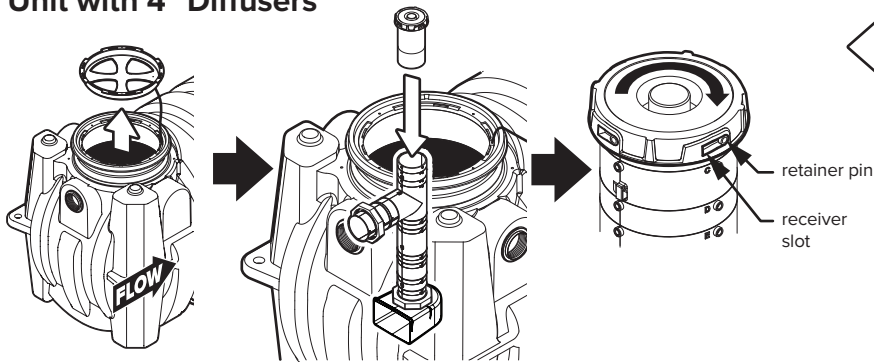

Remove Safety Star® insert and remove flow control cartridge from the parts bag. Slide flow control cartridge into top of inlet diffuser and rotate clockwise until cartridge drops onto the retainer pins. Continue rotating clockwise until pins are fully seated.

OR

Unit with 6" Diffusers

Before connecting piping and burial, fasten flow control plate to inlet bulkhead fitting using supplied screws. Holes in plate must line up with pre-drilled holes in bulkhead fitting and grooved side of plate must face the unit.

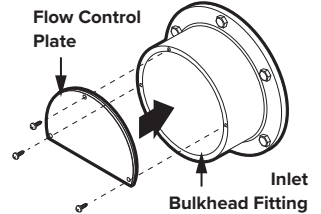

4b OPTIONAL: install extension handle

For easy flow control cartridge removal in deep burial installations, 1-1/2" PVC SCH. 40 pipe may be used as an extension handle. Before risers have been installed, cut pipe to length and attach to top of cover using PVC primer/cement. Extension handle length should be about 12" shorter than total riser height.

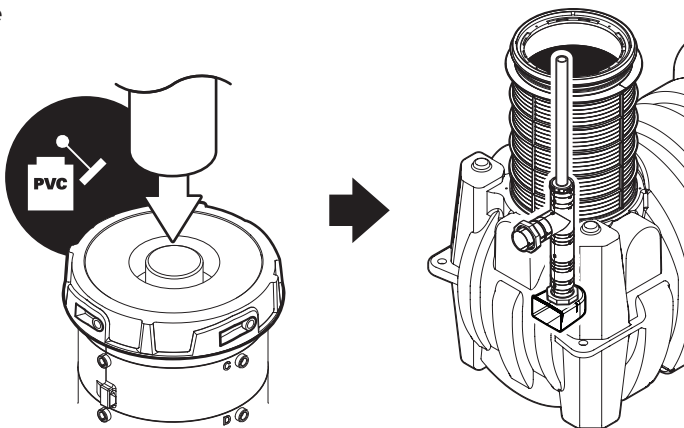

Finished installation showing optional extension handle

5 Connect Piping

5a Install plain end fittings

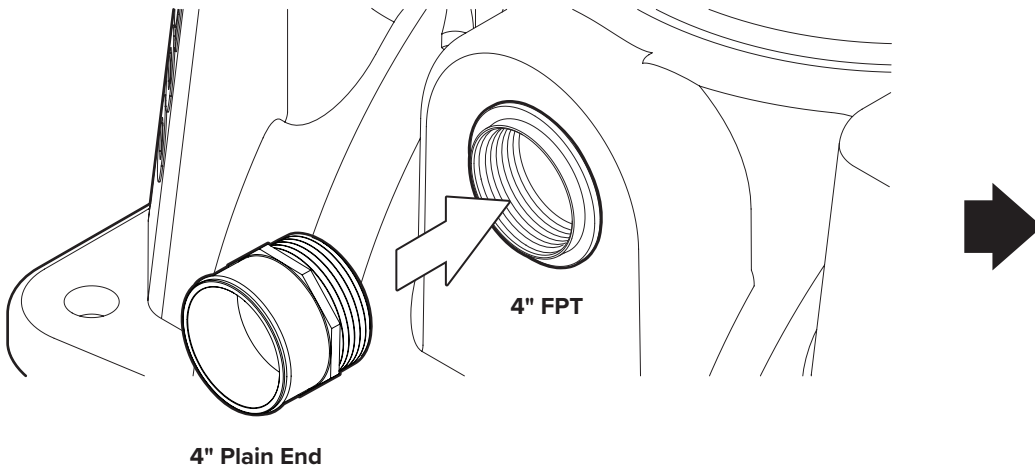

Screw plain end fittings (included) into bulkhead fittings using pipe thread sealant or tape approved for use with plastics. 6" connection types come pre-installed from the factory.

5b Connect interceptor to drain lines

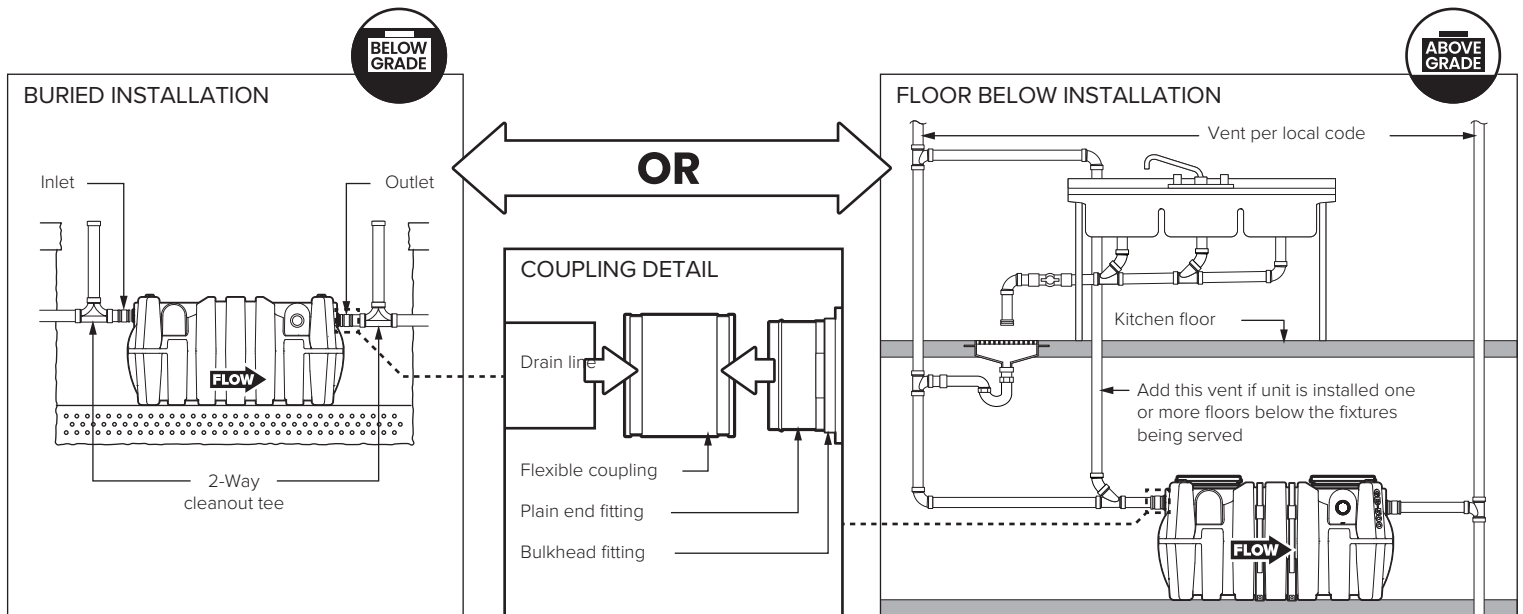

Place unit into final position and set level. Mechanically couple inlet and outlet drainage lines to unit. **Do not solvent weld.** Ensure all upstream fixtures are trapped. Vent per local code. Installation of 2-way cleanout tees to grade (by others) is recommended for buried installations.

6 Install AGS2 Above Grade Kit (sold separately)



The wet weight of the interceptor combined with high temperature kitchen water creates the potential for tank deformation in above grade installations. In these situations Above Grade Support Kit model AGS2 is required to be installed to maintain GB-500 structural integrity.

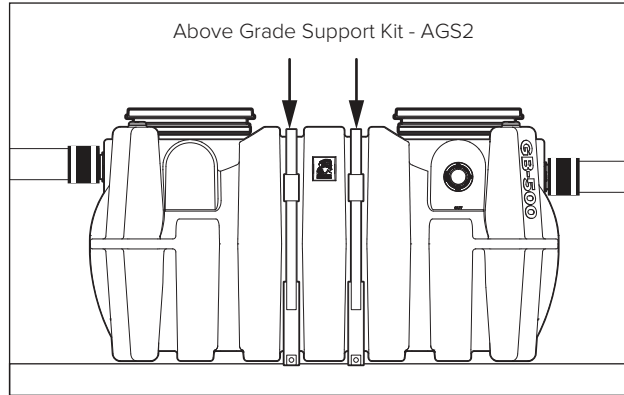

7 Wet or Air Test Piping Per Local Code

WARNING! DO NOT AIR TEST UNIT OR RISER SYSTEM!
Doing so may result in property damage, personal injury or death.



Have a Leak? Call customer care
at 913-951-3300
Hours 8am-5pm CST, M-F

8 Bring Covers Flush-to-Grade



The GB-500 is ready for burial depth of 49-1/2" from finished grade to bottom of tank (or 10-1/2" to centerline of inlet). Deeper burials will require extending the cover adapters and possibly adding risers.

8a Measure dimension X to determine riser height needed.

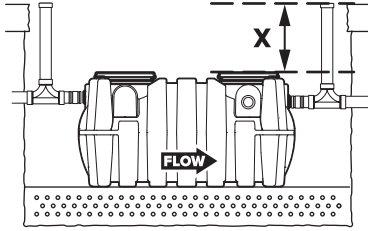

Riser Height Needed	Risers Required
0" - 4"	None (use adapter)
>4" - 34"	FCR2 (x2)
>34" - 64"	FCR2 (x4)
>64" - 94"	FCR2 (x6)

8b Install risers if required

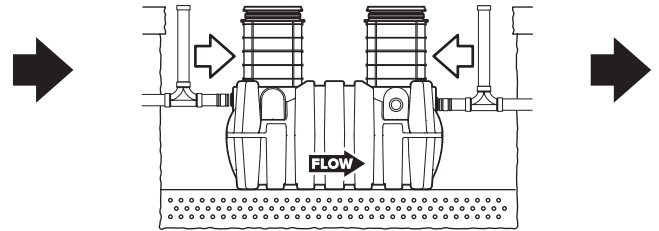

See instructions included with FCR2.

8c Make final cover adapter adjustments

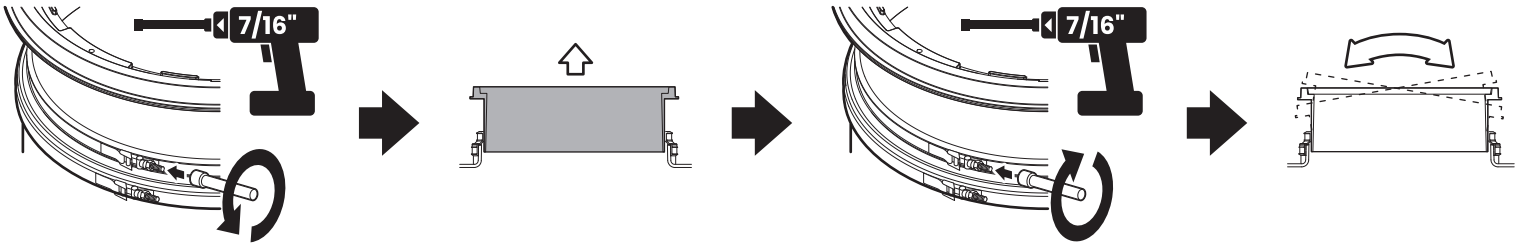

Loosen the cover adapter upper band clamp using 7/16" nut driver bit. Adjust cover adapter heights as needed. **Maintain a minimum 2-1/2" insertion depth.** Tighten upper band clamp to 5-8 ft. lbs. of torque using 7/16" nut driver bit. If required, cover adapters may now be tilted up to 10° in any direction using gasket flexibility.

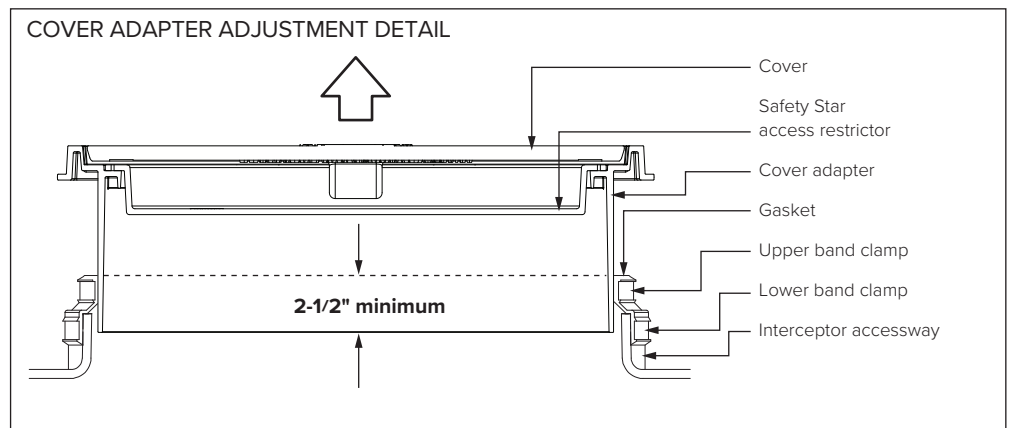

9 Install Anti-Flotation Anchor Kit



ONLY

If the installation location is in a high water table or at risk area (including but not limited to tidal surge areas, floodplains and areas that receive storm water) the GB-500 must be installed with either (2) Schier model AK1 anchor kits or 1 model AK2 anchor kit (with deadman anchors by others).

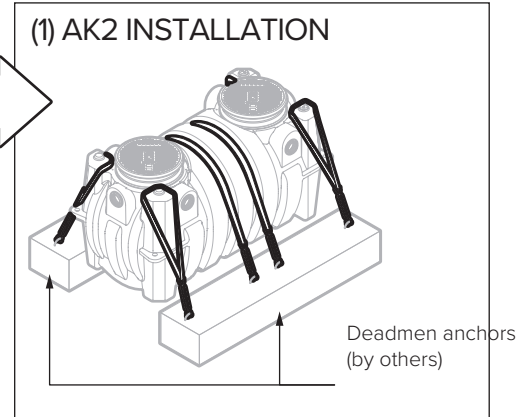
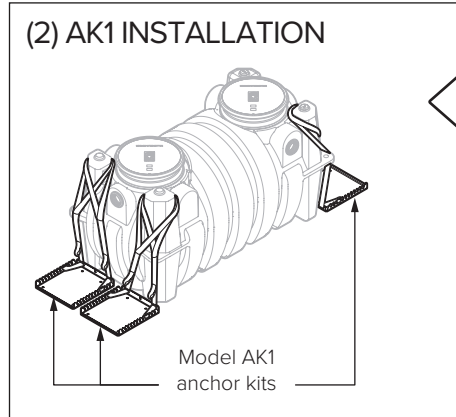

10 Backfill and Finished Grade



ONLY

10a Backfill

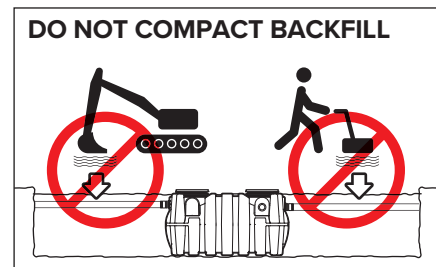
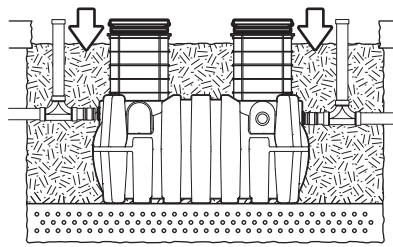
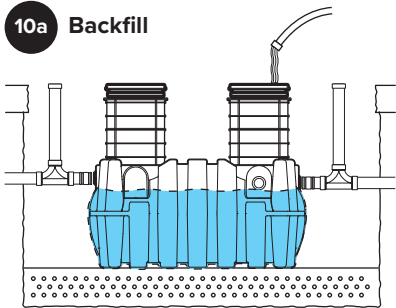

Fill unit with water for stabilization and float-out prevention. Backfill evenly around tank using crushed aggregate (approximately 3/4" size rock or sand with no fines) or flowable fill. **Do not compact backfill around unit.**

10b Pour concrete slab to finished grade

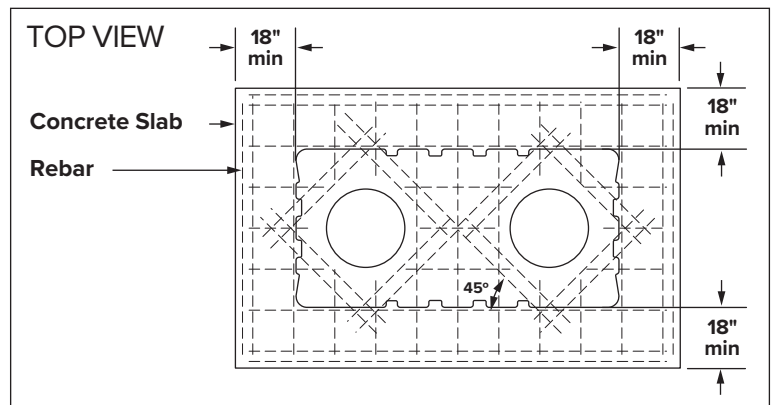
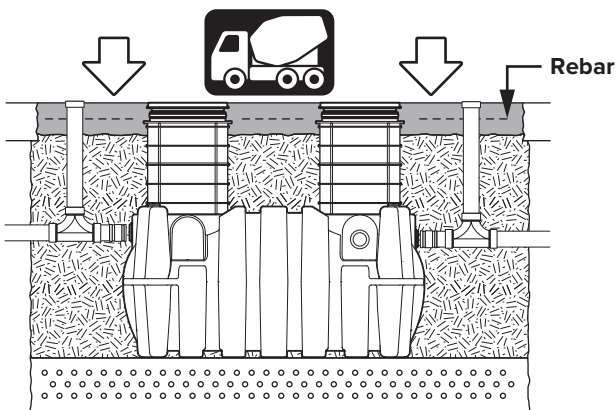

Vehicular Traffic Areas:

Minimum 8" thick concrete slab with rebar required. Thickness of concrete around covers to be determined by specifying engineer. If traffic loading is required the concrete slab dimensions shown are for guideline purposes only. Concrete to be 28 day compressive strength to 4,000 PSI. Use No. 4 rebar (ø 1/2") grade 60 steel per ASTM A615: connected with tie wire. Rebar to be 2-1/2" from edge of concrete and spaced in a 12" grid with 4" spacing around access openings.

Pedestrian Traffic or Greenspace Areas:

Minimum 4" thick concrete slab with rebar required.

SERIES INSTALLATIONS

For lower flow rates and higher grease storage requirements. Piping between units and two-way cleanout tees by others.

Below grade installations: All units must be level in the excavation pit. Note that downstream units must be buried 2" deeper than the adjacent, upstream fixture. Two-way cleanout tees extended to finished grade should be installed before the first unit inlet, after the last unit outlet and in between units (if there is a long run of pipe between units) for line cleaning purposes.

NOTE: When the flow control cartridge is required, it should only be installed on the first unit in the series.

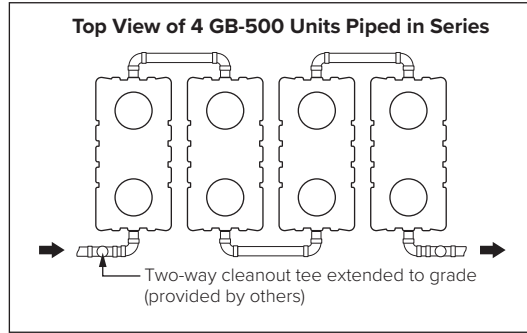

Rated Grease Capacities for Units Piped in Series

No. of Units in Series	Removal Efficiency
	100 GPM 95.3%
2	6,096 lbs.
3	9,144 lbs.
4	12,192 lbs.

