



Application Guide

Vitodens 222-F B2TB
Residential Boiler



Application Guide

The application examples contained in this document serve as a guideline only. These are not engineered drawings and are not intended to replace project designs provided by a professional engineer. It is the responsibility of the installing contractor to ensure all aspects of the system comply with the local authorities having jurisdiction.

© 2016 by Viessmann. All rights reserved.

No part of this book may be used or reproduced in any manner whatsoever without prior written permission.

For information, contact:

Viessmann Manufacturing Company Inc.
750 McMurray Road
Waterloo ON, N2V 2G5, Canada

Phone: 519-885-6300
Toll Free: 800-387-7373

www.viessmann.ca

VIESSMANN

Pre-Face / Overview

Each day Viessmann heating systems face a wide variety of requirements and challenges here in North America, and around the world. Whether in historically protected homes, modern commercial buildings, or in large facilities, Viessmann products meet every demand and offer solutions for all your needs: wood, oil, or gas fired boilers for both residential and commercial use, from 12KBTU to 17.9MBH (4 to 5263kW), domestic hot water storage tanks, solar collectors, Biogas technologies, and much more.

Viessmann also sets the standard for operational reliability, operating comfort, environmental friendliness and a long service life. All Viessmann products have one thing in common: they are based on a modular

technology strategy with one common platform. This way, different product versions can be created to fulfill each customer's specific requirements. In short, Viessmann takes care of all your needs, from start to finish.

Part of that is a comprehensive support program: A knowledgeable Viessmann sales representative network, technical training academy, and technical support personnel assist you right from the planning stage through to the installation and start-up phase of a project.



With Viessmann you are witnessing intelligent, high-tech boiler technology at work. We have selected some of the most interesting Viessmann applications from across North America for your reference.

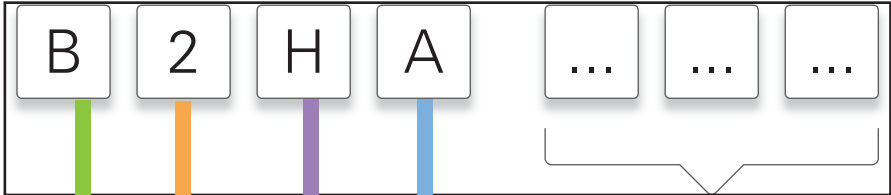

Identifying Boiler Nomenclature



Fuel Types

 Gas
  Oil

Efficiency

■ Low Temperature	A	F
■ Condensing	B	J
■ CHP	C	

Generation of Boiler

A B C ...



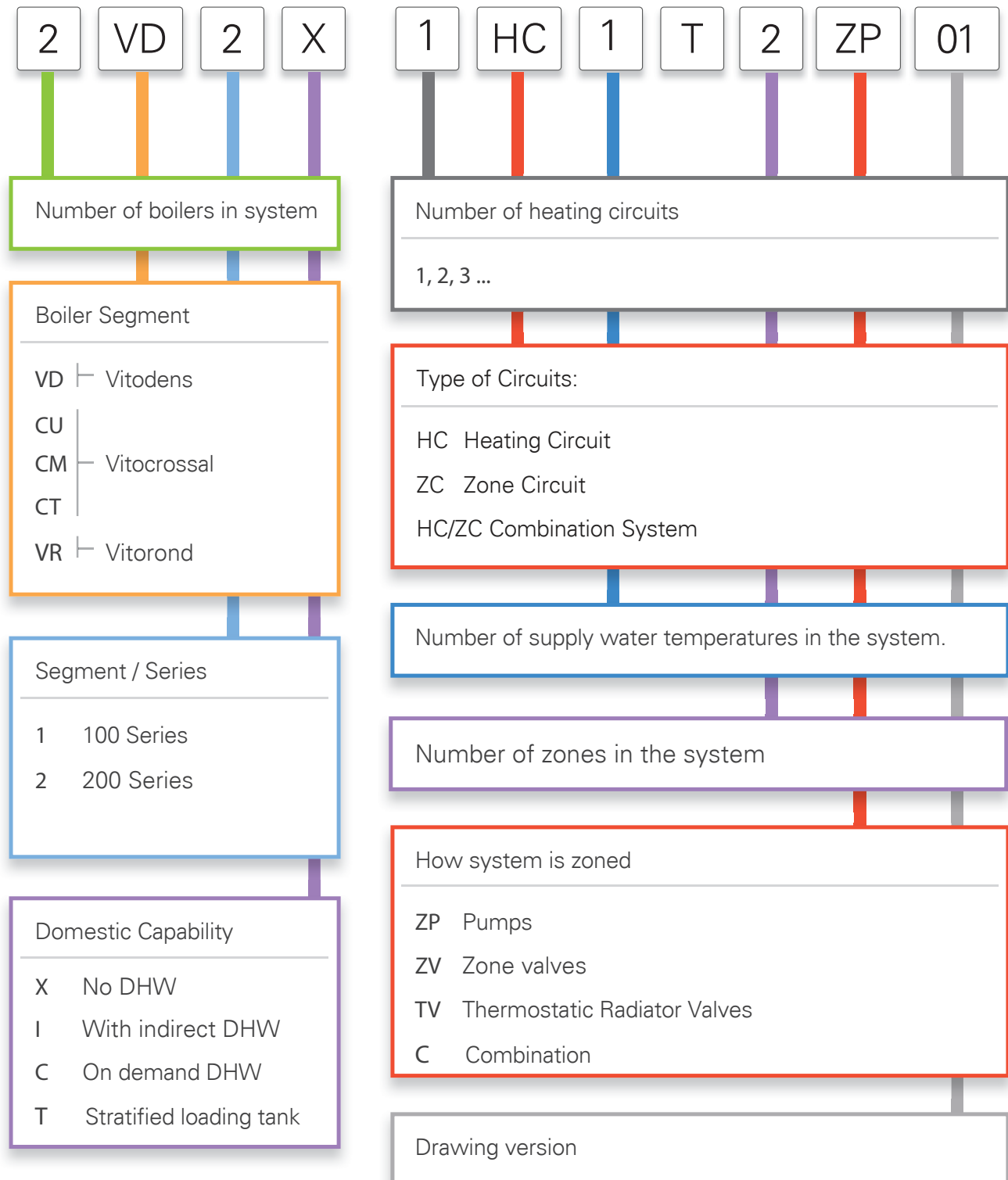

	Series	P
Segment	100	1
	200	2

	Heat Only	Circuit	Combi	Combi Comfort	Coiled Tubing Tank	Stratified Loading tank	Solar Heating For DHW	Solar Heating
Wall-Mounted	G	H	J	K	-	L	-	-
Floor Standing	-	R	-	-	S	T	U	V

Identifying Application Codes

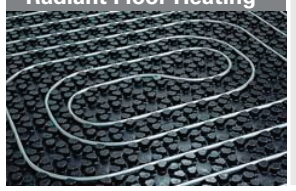

Recommended Product Applications

Application	Typical Supply Temperature	Vitodens 100	Vitodens 200/222-F	Vitocrossal 300 CU3A	Vitorond 100
Baseboard / Fan Coil 	High 160 -190 °F	◆ ¹	◆ ¹	★	★
Cast Iron Radiator 	Medium 140 -160 °F	★	★	★	◆ ²
Panel Radiator 	Medium 120 -160 °F	★	★	★	◆ ²
Radiant Floor Heating 	Low 80 -120 °F	★	★	★	●
Indirect DHW 	High 160 -190 °F	◆ ¹	◆ ¹	★	★
Air Handlers 	Medium 180 -120 °F	★	★	★	★

★ **Best Choice**

◆ Possible with limitations

● Not recommended

1- Limited maximum boiler supply water temperature.

2- Ensure boiler protection to prevent against low return water temperature

Refer to Technical Data Manual of each product for applicable certifications. Technical information subject to change without notice.

Component Index

Hydronic Components

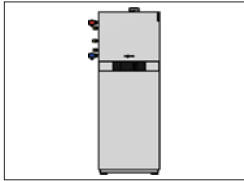

Vitodens 222-F with connection set

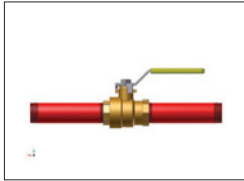

Ball valve

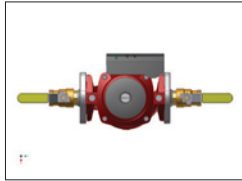

Circulator with isolation flanges



Low loss header

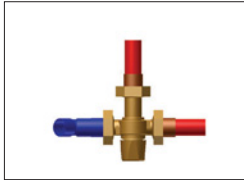

Thermostatic mixing valve

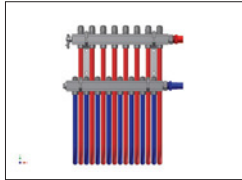

Radiant infloor manifold



Panel radiator

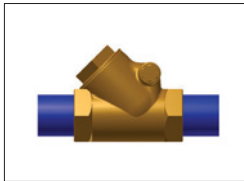

Flow check valve

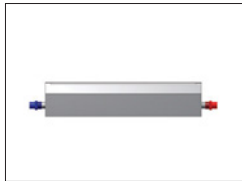

Hot water baseboard radiator

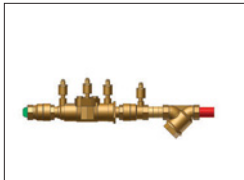

Boiler water feed with double back check valve

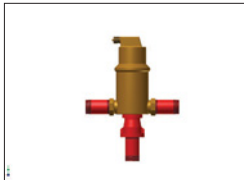

Air eliminator



Expansion tank



Purge assembly:
(sediment faucet and ball valve)

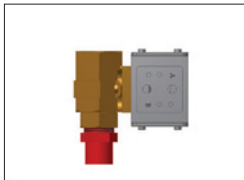

Zone valve

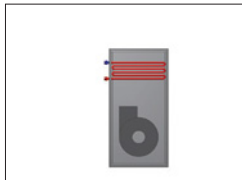

Hydronic air handler



Towel radiator

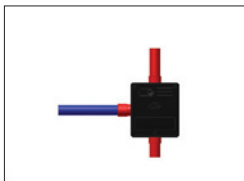

Viessmann 3-Way mixing valve
with actuator motor



Plate and frame heat exchanger

Electrical Components



Aquastat



Secondary low water cut-off



Motorized mixing valve



Outdoor temperature sensor

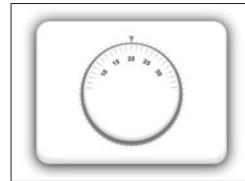

Thermostat



Temperature sensor



Viessmann Vitotrol

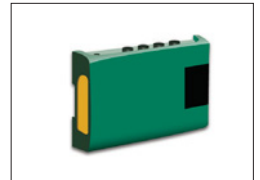

Multi-zone control

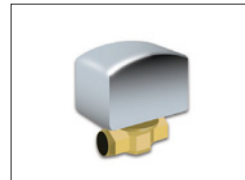

24V zone valve



Circulator



120 Volt power



Vitodens 222-F (B2TB)

Application #	Application Code	Page
Application 1 -	VD2T 1HC1T1ZP.01	26
Application 2 -	VD2T 1HC1T4ZV.01	30
Application 3 -	VD2T 1HC1T4ZP.01	34
Application 4 -	VD2T 2ZC2T2ZP.01	38
Application 5 -	VD2T 2ZC/HC2T2ZP.02	42
Application 6 -	VD2T 3HC3T3ZP.01	46

Product Information

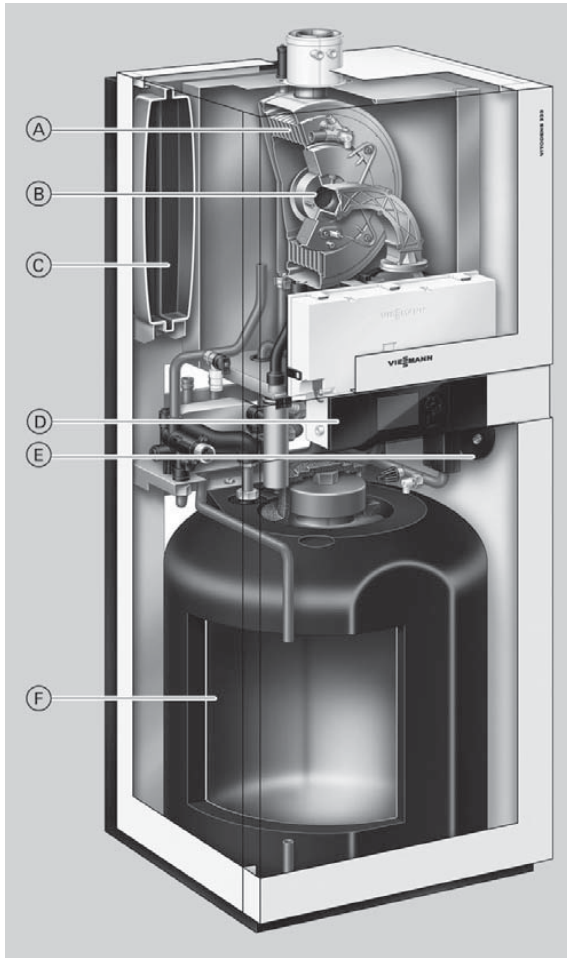

Product may not be exactly as shown

- A Stainless steel Inox-Radial heat exchanger for high operational reliability, a long service life and high heating output in the smallest space
- B Modulating Matrix cylinder gas burner for extremely clean combustion
- C Integral diaphragm expansion tank
- D Digital boiler control unit
- E Integral, 3-speed high efficiency circulation pump
- F Stainless steel DHW primary storage tank.

The flue gas temperature is only approximately 9-27°F (5-15°C) above boiler return temperature (see chart below).

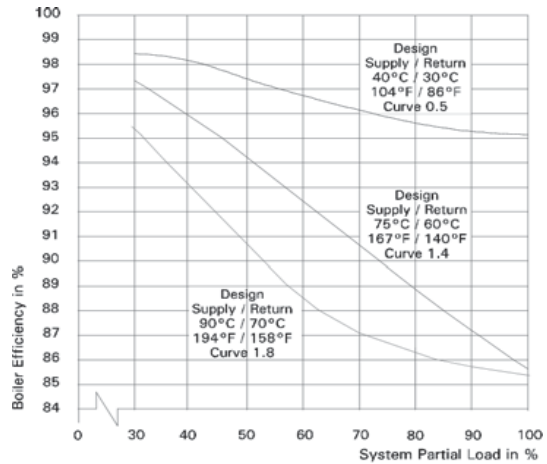

Vitodens 222-F boiler efficiency dependent on system heating water return temperatures and load conditions

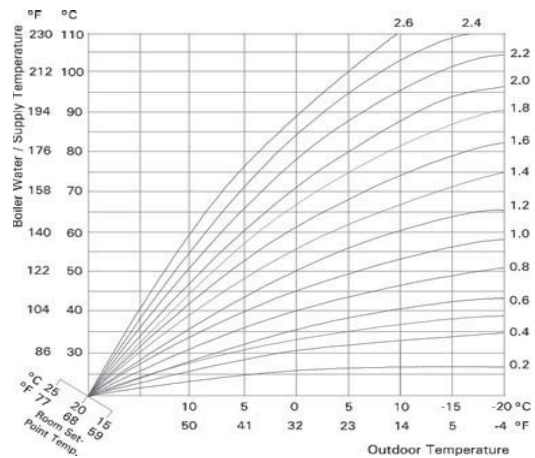

Product Information

Boiler Model No. 222-F B2TB		68	125
CSA input Natural Gas (NG)	MBH	12-68	19-125
	(kW)	(3.5-20)	(5.5-37)
CSA input Liquid Propane Gas (LPG)	MBH	12-68	31-125
	(kW)	(3.5-20)	(9-37)
CSA output/DOE *1 heating capacity NG	MBH	11-64	18-117
	(kW)	(3.2-19)	(5-34)
CSA output/DOE *1 heating capacity LPG	MBH	11-64	29.5-117
	(kW)	(3.2-19)	(8.6-34)
Net AHRI rating *2	MBH	55	102
	(kW)	(16)	(30)
Heat exchanger surface area	ft. ²	12.96	12.96
	m ²	1.2	1.2
Min. gas supply pressure			
Natural gas	"w.c.	4	4
Liquid propane gas	"w.c.	10	10
Max. gas supply pressure *3			
Natural gas	"w.c.	14	14
Liquid propane gas	"w.c.	14	14
A.F.U.E.	%	95	95
Weight (including installation fittings)	lbs	302	302
	(kg)	(137)	(137)
Boiler water content	USG	1.02	1.02
	(L)	(3.88)	(3.88)
Boiler max. flow rate *4	GPM	6.2	6.2
	(L/h)	(1400)	(1400)
Expansion tank *5 (for heating system side)			
Precharge pressure	psig	12	12
Capacity	USG	3.2	3.2
	(L)	(12)	(12)
Max. operating pressure at 210°F (99°C)	psig	45	45
	bar	3	3
Boiler water temperature			
- Adjustable high limit (AHL) range space heating (steady state)	°F	68 to 180	68 to 180
	(°C)	(20 to 82)	(20 to 82)
- Fixed high limit (FHL)	°F (°C)	210 (99)	210 (99)
Boiler connections			
Boiler heating supply and return	NPTM"	3/4"	3/4"
Pressure relief valve	NPTF"	3/4"	3/4"
Drain valve	(male	3/4"	3/4"
	thread)		
Boiler supply/return for indirect-fired DHW storage tank (field supplied)	NPT"	3/4"	3/4"
	NPTF"	3/4"	3/4"

*1 Output based on 140°F (60°C), 120°F (49°C) system supply/return temperature.

*2 Net AHRI rating based on piping and pick-up allowance of 1.15.

*3 If the gas supply pressure exceeds the maximum gas supply pressure value, a separate gas pressure regulator must be installed upstream of the heating system.

*4 See "Waterside Flow" starting on page 8 in this manual.

*5 Determine the required size of the expansion tank to be installed in the heating system. If the integral expansion tank is insufficient, install a suitably sized expansion tank on site.

Product Information

Boiler Model No. 222-F B2TB		68	125
Dimensions			
Overall depth	inches (mm)	23½ (595)	23½ (595)
Overall width	inches (mm)	23⅝ (600)	23⅝ (600)
Overall height *12	inches (mm)	64 (1625)	64 (1625)
Flue gas *6			
Temperature (at boiler return temperature of 86°F (30°C))			
- at rated full load	°F (°C)	113 (45)	113 (45)
- at rated partial load	°F (°C)	95 (35)	95 (35)
Temperature (at boiler return temperature of 140°F (60°C))			
	°F (°C)	154 (68)	154 (68)
Average condensate flow rate *7			
with natural gas and T _S /T _R =122/86°F (50/30°C)			
	USG/h (L/h)	2.6-3.4 (10 - 12)	4-4.5 (15 - 17)
Condensate connection *8			
	hose nozzle Ø in.	¾-1"	¾-1"
Boiler flue gas connection *9			
	Ø in. (mm)	2⅜" (60)	2 ⅜" (60)
Combustion air supply connection (coaxial)			
	outer Ø in. (mm)	4" (100)	4" (100)
Sound Rating			
- at maximum input	dB	41	51
- at minimum input	dB	35	36
DHW storage tank			
DHW storage tank capacity	USG (L)	26.5 (100)	26.5 (100)
Temperature and pressure relief valve (factory installed)	psig/temp	150 / 210°F (99°C)	150 / 210°F (99°C)
Max. allowable operating pressure (DHW)	psig	150	150
Storage tank test pressure	psig	300	300
Continuous DHW output	MBH (kW)	61 (17.8)	114 (33.4)
Continuous DHW output draw rate *10	GPM (L/min.)	1.8 (6.6)	3.3 (12.3)
Max. DHW draw rate (over 10 min. period) *10	USG (L)	44 (166)	60 (227)
Standby losses *11			
	BTU/24h	4435	4435
	BTU/h	184	184
	°F/h	0.8	0.8

*6 Measured flue gas temperature with a combustion air temperature of 68°F (20°C).

*7 Based on typical boiler cycles, including partial load conditions.

*8 Requires 1 inch (25 mm) tubing. See the Installation Instructions of the Vitodens 222-F, B2TB for details.

*9 For side wall vent installations (coaxial system):

Do not exceed max. equivalent length specified in the Installation Instructions of the Vitodens 222-F, B2TB Venting System.

Do not attempt to common-vent Vitodens 222-F, B2TB with any other appliance.

Side wall coaxial vent installation must include Viessmann protective screen!

For details refer to the Installation Instructions for the Vitodens 222-F, B2TB Venting System.

*10 Based on a temperature rise of 70°F (21°C), 50°F to 120°F (10°C to 49°C).

*11 Measured values are based on room temperature of 68°F (20°C) and a domestic hot water temperature of 149°F (65°C).

*12 Add 1⅝ in. (40 mm) when using the optional accessory seismic bracket kit.

For information regarding other Viessmann System Technology componentry, please reference documentation of respective product.

Note: For high altitude installation at 10,000 ft. (3050 m) the input for 222-F, B2TB 68 and 125 will have an altitude de-ration of 21%

Boiler Dimensions

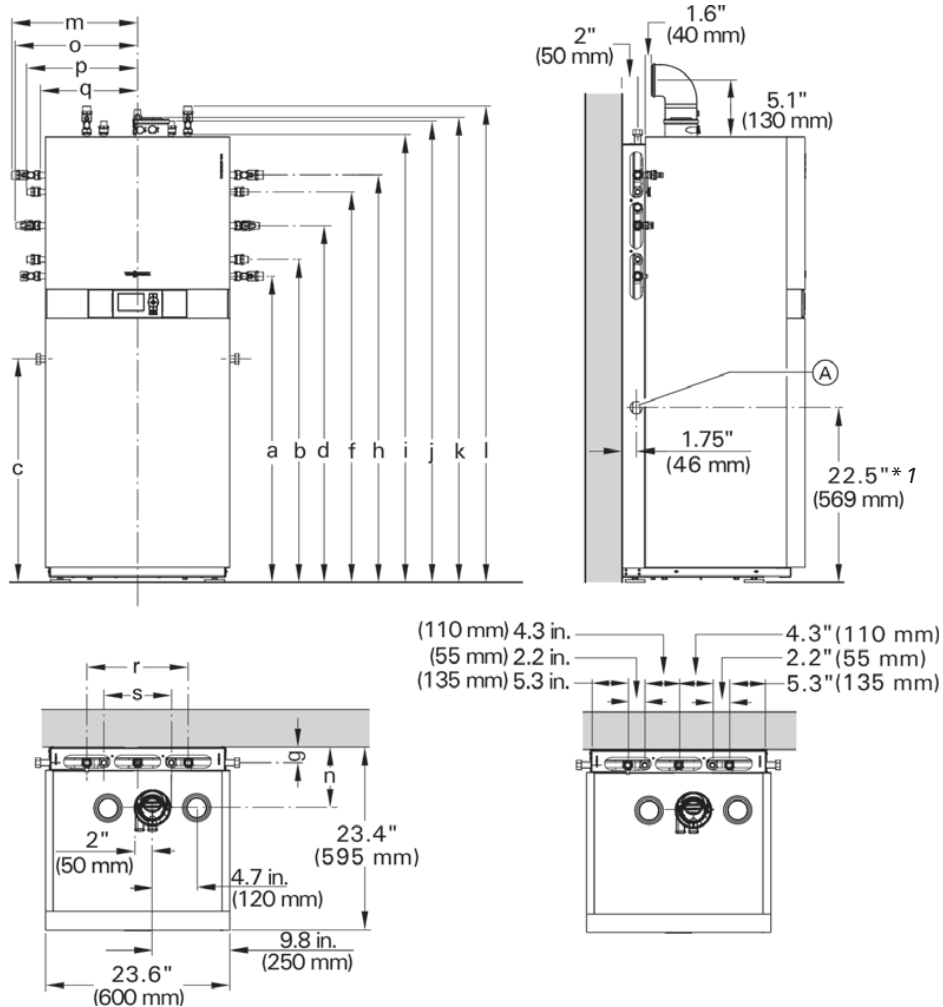

Note: The dimensional drawing shows example fittings for upward connection and connection to the left/right, for installation on finished walls. Order the connection sets separately as accessories. For the dimensions of the individual connection sets, see the design information.

Model B2TB 68 and 125			Model B2TB 68 and 125		
a * 1	in. (mm)	46.1 (1172)	k * 1	in. (mm)	65.6 (1665)
b * 1	in. (mm)	48.3 (1227)	l * 1	in. (mm)	68.0 (1726)
c * 1	in. (mm)	28 (710) approx.	m	in. (mm)	16.1 (410)
d * 1	in. (mm)	52.6 (1337)	n	in. (mm)	8.8 (224)
f * 1	in. (mm)	57.0 (1447)	o	in. (mm)	15.3 (389)
g	in. (mm)	2.0 (50)	p	in. (mm)	14.2 (361)
h * 1	in. (mm)	59.1 (1502)	q	in. (mm)	12.6 (320)
i * 1	in. (mm)	64.2 (1630)	r	in. (mm)	13.0 (330)
j * 1	in. (mm)	65.6 (1666)	s	in. (mm)	8.7 (220)

Note: All height dimensions of the boiler have a tolerance of +.6 in. (+15 mm) due to the factory installed adjustable feet

* 1 Add 1 5/8 in. (40 mm) when using the optional accessory seismic bracket kit.

Note: All height dimensions of the boiler have a tolerance of +.5 in. (+13 mm) due to the seismic bracket adjustable feet.

Service Clearances

Reccomended minimum service clearances

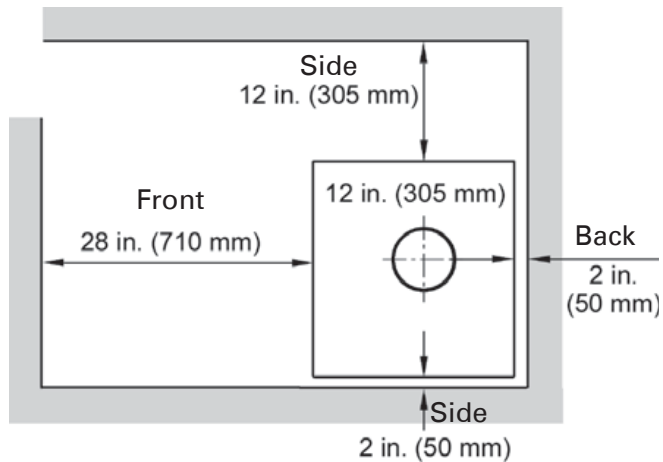

Minimum clearances to combustibles

Boiler model B2TB	68	125
Top	0	0
Sides (left and right)	0	0
Vent pipe	0	0
Front (alcove or closet)	0	0
Rear	0	0
Floor	combustible	combustible

Note:The Vitodens boiler has passed the zero inches vent clearance to combustibles testing requirements dictated by the Harmonized Standard ANSI Z21.13, CSA 4.9 (latest edition) and therefore is listed for zero clearance to combustibles when vented with a single wall special venting system (AL-29-4C material). The zero inches vent clearance to combustibles for the Vitodens boiler supercedes the clearance to combustibles listing that appears on the special venting system label.

Waterside Flow (primary circuit)

Waterside Flow (primary circuit)

The Vitodens 222-F, B2TB is designed for closed loop, forced circulation hot water heating systems only. Use standard friction loss method for pipe sizing. Observe boiler maximum and minimum flow rate limitations. If system flow rate exceeds boiler maximum flow rate (as stated below), falls below the minimum flow rate or if system flow rate is unknown, Viessmann strongly recommends the installation of a low-loss header. An alternative method may be used, such as primary secondary piping using closely spaced tees.

A low-loss header offers additional benefits not provided by a pair of closely spaced tees. Viessmann therefore strongly recommends and prefers the use of a low-loss header over closely spaced tees. Once the low-loss header is connected, the built-in low-loss header logic of the Vitodens 222-F boiler ensures the required Δt across the system through the sensory communication between the low-loss header and the boiler.

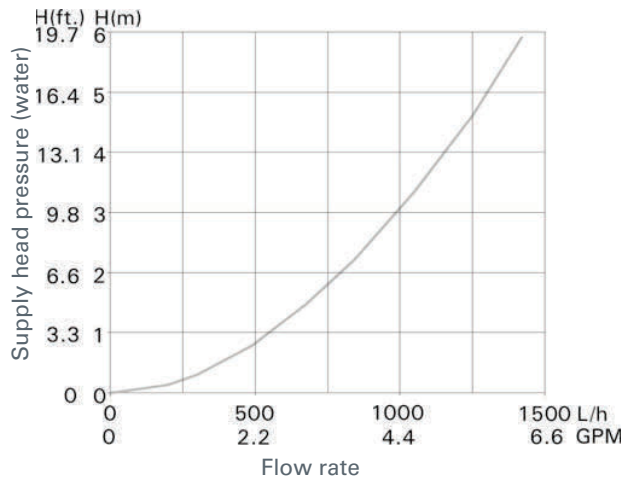

Pressure drop (primary circuit) for Vitodens 222-F, B2TB 68 and 125 six sizing an on-site circulation system Max. flow rate: 6.2 GPM (14 L/h)

Model B2HB 68		1 boiler
Output (NG/LPG)		
	MBH	64
Δt for NG/LPG		
20°F (11°C) rise	GPM (L/h)	6.4 (1453)
25°F (14°C) rise	GPM (L/h)	5.1 (1163)
30°F (17°C) rise	GPM (L/h)	4.3 (969)
35°F (19.5°C) rise	GPM (L/h)	3.7 (830)
40°F (22°C) rise	GPM (L/h)	3.2 (727)

Model B2HB 125		1 boiler
Output (NG/LPG)		
	MBH	117
Δt for NG/LPG		
20°F (11°C) rise	GPM (L/h)	11.7 (2657)
25°F (14°C) rise	GPM (L/h)	9.4 (2126)
30°F (17°C) rise	GPM (L/h)	7.8 (1771)
35°F (19.5°C) rise	GPM (L/h)	6.7 (1518)
40°F (22°C) rise	GPM (L/h)	5.9 (1328)

Pump Information

Pump Information

Vitodens 222F B2TB 68-125 are equipped with a boiler/system pump. The system pump flow must be selected on Δt . If the system flow exceeds the boiler's maximum flow rate, a low-loss header is strongly recommended.

IMPORTANT

Pump selection must be based on accurate system flow and pressure drop calculations (includes DHW sizing).

Low-Loss Header Application

Sizing of Low-Loss Header in a Residential Single-Boiler Application

Boiler Model	No. of Boilers	Boiler Max. Flow Rate GPM (L/h)	Typical System Flow Rates							Viessmann Low-loss Temp. Sensor Required*2
			Δt *1	°F (°C)	20 (11.0)	25 (13.9)	30 (16.8)	35 (16.1)	40 (13.4)	
B2TB 68	1	6.2 (1400)	System Flow Rate LLH Required LLH Model	GPM (L/h)	6.4 (1453) Yes 80/60	5.1 (1163) Optional 80/60	4.3 (969) Optional 80/60	3.7 (830) Optional 80/60	3.2 (727) Optional 80/60	included
B2TB 125	1	6.2 (1400)	System Flow Rate LLH Required LLH Model	GPM (L/h)	11.7 (2657) Yes 80/60	9.4 (2126) Yes 80/60	7.8 (1771.6) Yes 80/60	6.7 (1518) Yes 80/60	5.9 (1328) Optional 80/60	included

* 1 For system $\Delta t < 20^\circ\text{F}$ (11°C) use low-loss header sizes for $\Delta t 20^\circ\text{F}$ (11°C).

* 2 Low-Loss temperature sensor - is included with the boiler for use in single-boiler applications.

Note: The Vitodens 222-F comes equipped with a factory preset integrated boiler pump.

Internal Boiler Pump Information

Hydronic Components

Grundfos UPS15-78 three speed heating circuit/DHW circuit pump for Vitodens 222-F, B2TB boilers (in the factory setting, the pump speed is preset to 'speed three')

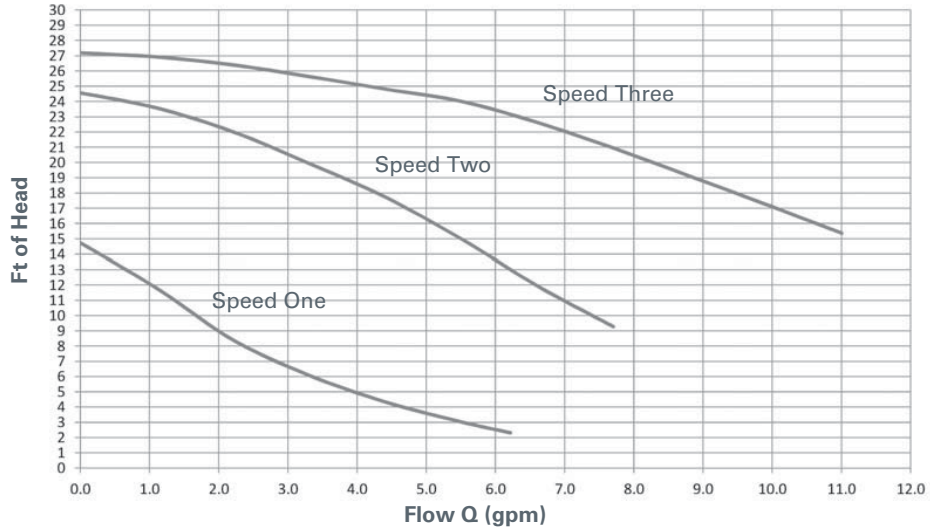

Performance chart courtesy of Grundfos

Pump Model	Grundfos UPS15-78	
Rated voltage	VAC	115
Rated current	A max.	1.15
	A min.	0.8
Capacitor	μ F	8
Power consumption	W max.	130
	W min.	80

Grundfos UPS15-78 residual head pressure

Residual head of built-in three speed pump used with Vitodens 222-F, B2TB

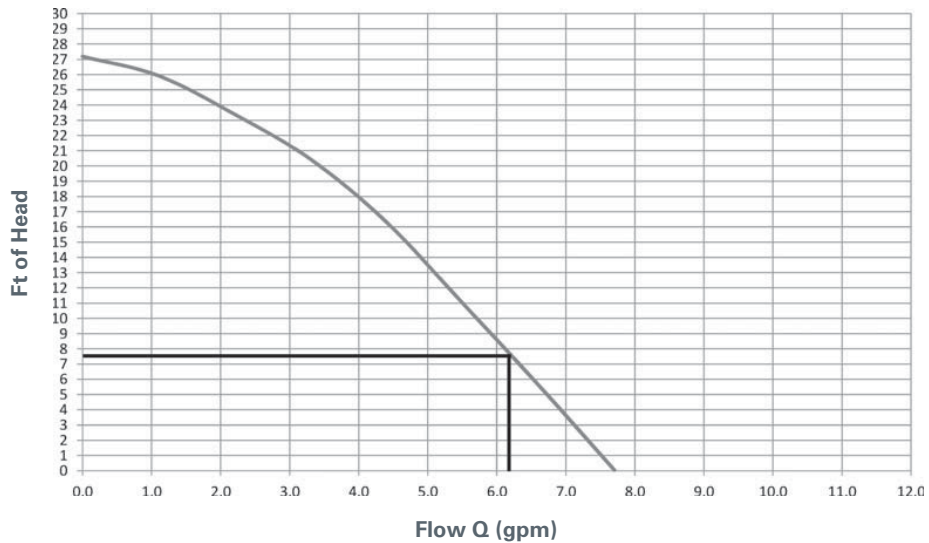

System Design Considerations

Boiler location

As a direct vent appliance, the Vitodens 222-F can be installed for room air independent operation (sealed combustion) regardless of size and ventilation method of the room in which it is located.

The Vitodens 222-F can be installed, for example, in the main living area of a house, in non-ventilated utility rooms, cupboards, closets and alcoves with no clearance required from combustible materials, as well as in attics with a direct outlet for the flue gas/fresh air system. Follow all local and national codes.

Flue gas system

Viessmann PPS (Polypropylene) concentric flue gas/fresh air systems for room air independent operation (sealed combustion) and side wall venting are tested to ANSI Z21.13 - CSA 4.9 - (latest edition) and are certified together with the Vitodens 222-F boiler as a constructional unit.

The Vitodens 222-F boiler may also be vented vertically, using an AL29-4C® special stainless steel, single-wall, room air dependent venting system (UL listed for category IV). For a more detailed description of the direct vent and single-wall vent system, please refer to the Vitodens 222-F Venting System Installation Instructions.

Flue gas temperature protection

Flue pipes used for the Vitodens 222-F are suitable for max. flue gas temperatures of up to 230°F (110°C). No flue gas temperature protection is required as the maximum permissible flue gas temperature is not exceeded in any operating condition or in the event of malfunctioning.

Low water cut-off

A low water cut-off may be required by local codes. If the boiler is installed above the radiation level, a low water cut-off device of approved type must be installed in all instances. An approved type low water cut-off device must be provided by the heating contractor. Do not install an isolation valve between the boiler and the low water cut-off.

Water connections

Vitodens 222-F boilers can be used in any fully pumped hot water heating system.

Minimum system pressure is 14 psig.

Chemical corrosion protection products

Corrosion does not typically occur in sealed heating systems which have been correctly installed and are correctly operated.

Many manufacturers of plastic pipes recommend the use of chemical additives. In this case, only those commercially available corrosion protection products approved for boilers with domestic hot water heating via single-wall heat exchangers (instantaneous plate heat exchangers or DHW tanks) must be used.

Water quality

Treatment for boiler feed water should be considered in areas of known problems, such as where a high mineral content and hardness exist. In areas where freezing might occur, an antifreeze may be added to the system water to protect the system. Please adhere to the specifications given by the antifreeze manufacturer. Do not use automotive silicate based antifreeze.

Please observe that an antifreeze/water mixture may require a backflow preventer within the automatic water feed and influence components such as diaphragm expansion tanks, radiation, etc. Maximum antifreeze content is 50% for the Vitodens 222-F boiler. Do not use antifreeze other than specifically made for hot water heating systems. System also may contain components which might be negatively affected by antifreeze. Check total system frequently when filled with antifreeze. Advise system operator/ultimate owner that system is filled with a glycol mix. The heating contractor must provide a MSDS (Material Safety Data Sheet) for the antifreeze used to the system operator/ultimate owner.

Total permissible hardness of the fill and top-up water

Total heating output	Specific heating volume					
	<5 USG per 3412 BTU		≥ 5 USG per 3412 BTU to <13 USG per 3412 BTU		≥ 13 USG per 3412 BTU	
MBH						
≤ 170	300 pp	17.5 gpg	200 ppm	11.7 gpg	2 ppm	0.11 gpg
>170 to ≤ 682	200 pp	11.7 gpg	150 ppm	8.8 gpg	2 ppm	0.11 gpg
>682 to ≤170	150 pp	8.8 gp	2 ppm	0.11 gpg	2 ppm	0.11 gpg
> 2050	2 ppm	0.11 gpg	2 ppm	0.11 gpg	2 ppm	0.11 gpg

ppm - parts per million

gpg - grains per gallon

System Design Considerations (*continued*)

System layout

- The max. boiler water temperature for space heating and DHW production is 180°F (82°C) for models B2TB 68 and 125. To minimize distribution losses, Viessmann recommends that the heating and domestic hot water systems be based on a maximum boiler supply temperature of 158°F (70°C).
- Due to the low return temperatures required for gas condensing, no mixing valves should be used in the heating circuit whenever possible. If mixing valves are required, e.g. for multi-circuit systems or underfloor heating systems, only 3-way mixing valves must be used.
Do not use 4-way mixing valves with condensing boilers.

Underfloor heating systems

For underfloor heating systems Viessmann recommends the use of plastic tubing with an oxygen diffusion barrier in order to prevent the diffusion of oxygen through tubing. If plastic tubing without an oxygen diffusion barrier is used in underfloor heating systems, Viessmann recommends that such systems be separated from the boiler with a heat exchanger.

Underfloor heating systems and heating circuits containing a very large volume of water must be connected to the boiler via a 3-way mixing valve; please refer to the applicable installation example in this manual.

Oxygen diffusion barrier underfloor tubing

The boiler warranty does not cover leaks resulting from corrosion caused by the use of underfloor plastic tubing without an oxygen diffusion barrier. Such systems must have the non-oxygen diffusion barrier tubing separated from the boiler with a heat exchanger. Viessmann recommends the use of underfloor plastic tubing with an oxygen diffusion barrier.

Warranty

Our warranty does not cover damages resulting from the following:

- installation or service by unqualified and unlicensed personnel.
- attempting to perform any repair work on the boiler other than that mentioned in the boiler literature.
- tampering with or attempting, without Viessmann permission, to readjust the factory settings of the;
 - combination gas valve
 - combustion air opening of the burner blower
- leaks resulting from corrosion caused by the use of underfloor plastic tubing without an oxygen diffusion barrier. For detailed warranty information, please read warranty sheet supplied with product.

Product Information

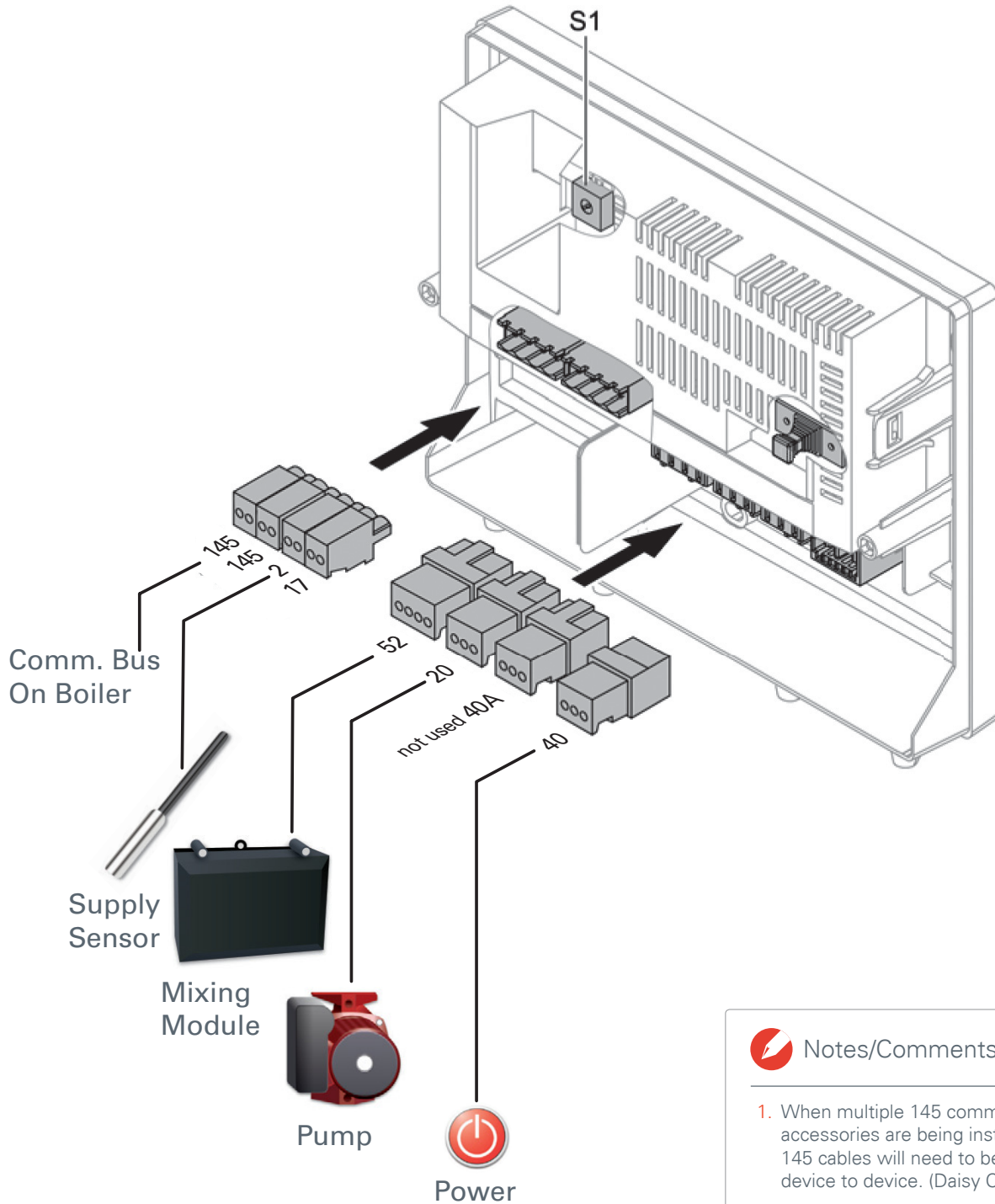

-  Notes/Comments
1. When multiple 145 communication accessories are being installed, 145 cables will need to be run from device to device. (Daisy Chain)
 2. Ensure to set the S1 switch to assign the mixing valve heating circuit.

Vitodens 222-F, B2TB 68 and 125



Notes/Comments

Zone Control Wizard Setup



Notes/Comments

1. Power Boiler ON
2. Setting of Time and Date
3. Press Menu+OK buttons to access Service Menu
4. Down Arrow to Service Functions
5. Press OK
6. Activate Yes/No
7. Arrow up to YES
8. Press OK

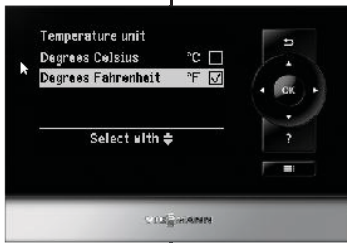

Select number of ZC circuits 1, 2 or 3

ZC2 and ZC3 Configuration Setup

System with 1 Zone Circuit

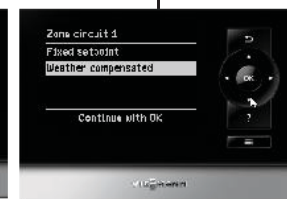
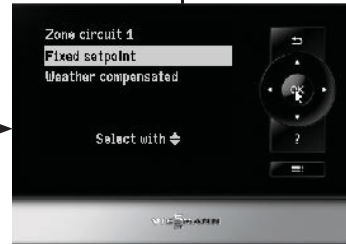
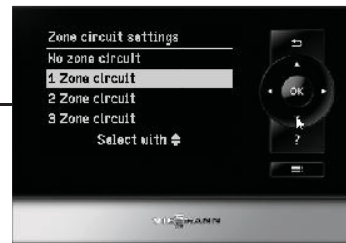

Press OK at each screen to enter setting and move to next step

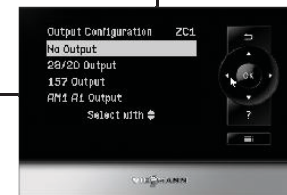



System with 2 Zone Circuits

System with 3 Zone Circuits

OR

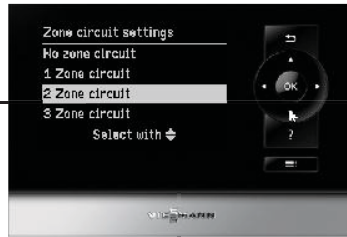

OR

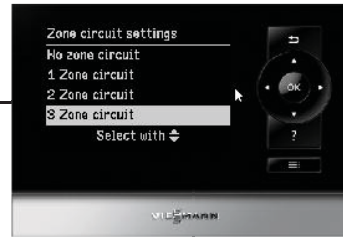

Operational Screen Information

ZC Fixed Setpoint Configured



ZC Weather Compensated Configured



User Interface Details:

1. Indication of ZC circuit boiler is configured for ZC1/ZC2/ZC3 use arrows left or right to select.
2. Display will show when a ZC call is present and a if ZC1/ZC2/ZC3 are configured with an associated pump output.
3. Display of actual boiler water temperature.
4. Flame indication when burner ON and will show % of modulation.
5. Target temperature of zone. The Fixed Setpoint will show the set temperature during configuration and Weather Compensated will show target based on slope and shift.
6. Outdoor temperature is shown when Weather Compensated ZC is configured.

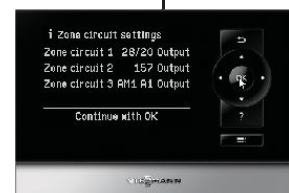
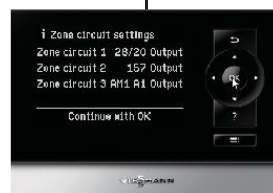

Product Information

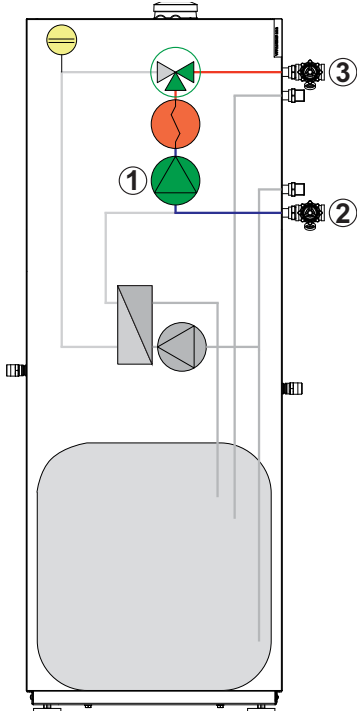

One key aspect of the Vitodens 222-F is its unique approach to meeting varying loads of DHW demands. The Advanced Storage Tank Loading System (STLS) technology ensures a reliable and efficient DHW supply by combining storage and tankless technology. The STLS utilizes a plate heat exchanger and innovative piping strategy to combine the benefits of both a storage type water heater and on-demand DHW. This allows the 222-F to meet a varying range of loads from small to large without affecting the operation of the boiler. Here's how it works:

Heating Mode

In heating mode the boiler functions in the exact same way as a typical low mass hi efficiency condensing gas boiler. The internal circulator(1) draws in cool return water from the system(2), pushes it through the boiler where it is heated up and sent back out into the system(3).

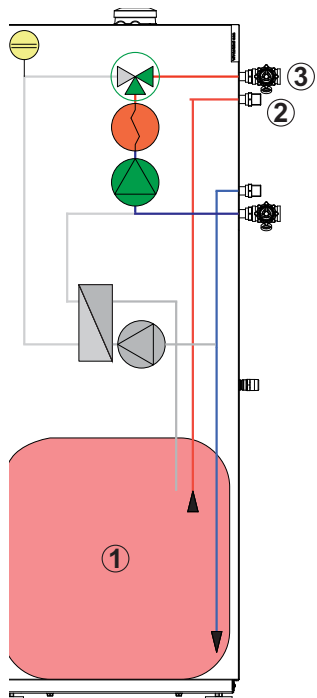

Micro DHW Loads

A demand for DHW is where the 222-F starts to outshine all other products on the market. Imagine you turn the hot water tap on to rinse a glass, or better yet trickle a little bit of hot water while you shave. A typical on demand type water heater would short cycle or may not even turn on for such a small amount of DHW. The 26 gallon storage tank on the 222-F addresses this by simply storing a small amount of hot water(1) for these types of situations. Therefore the small volume of hot water(2) is taken from the onboard storage tank preventing the boiler from short cycling and eliminating common issues with on demand units. This will also allow the boiler to continue to provide heat to the heating system uninterrupted(3).

Product Information

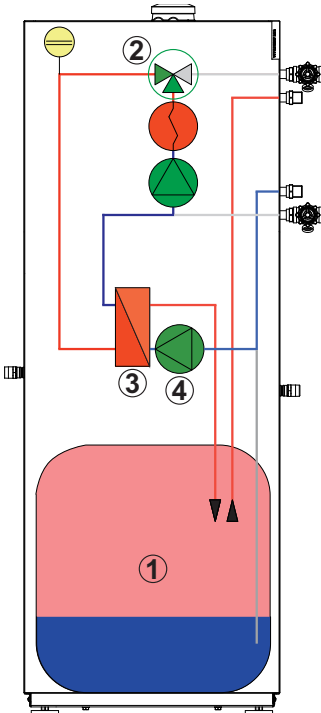

Entering DHW Mode

After the bottom 1/3 of the hot water is removed from the storage tank(1), the diverting valve switches from heating mode to DHW(2) and begins supplying heat to the plate heat exchanger(3). At the same time, the DHW pump(4) is powered and begins circulating a predefined amount of domestic water through the plate heat exchanger(3.3gpm). When in this mode, there is no circulation to the heating system and this now gives the DHW load the priority.

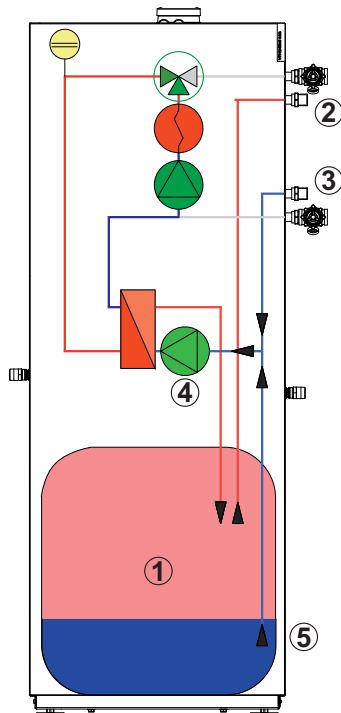

Small-Medium DHW Loads (0.5-3.4 GPM)

As a result of the drop tube design in the storage tank(1), the boiler has the ability to recharge the storage tank and satisfy the DHW demand simultaneously when under small loads. Here's how this works; If a DHW load of 1.8 GPM is exiting the boiler(2), then 1.8 GPM of cold water must enter the boiler(3). Now because the DHW circulator(4) is drawing in 3.3 GPM of cold water, it will take the 1.8g of fresh water, and the remaining 1.6g will come from the storage tank(5). Unlike storage sytle water heaters the 222-F tank is charged from the top-down. This ensures a more consistant supply temperature and prevents the incoming cold water from diluting the entire temperature of the storage tank. This is the STLS!

Thermal image of the STLS

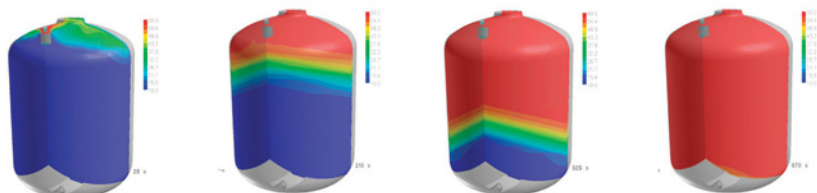

Product Information

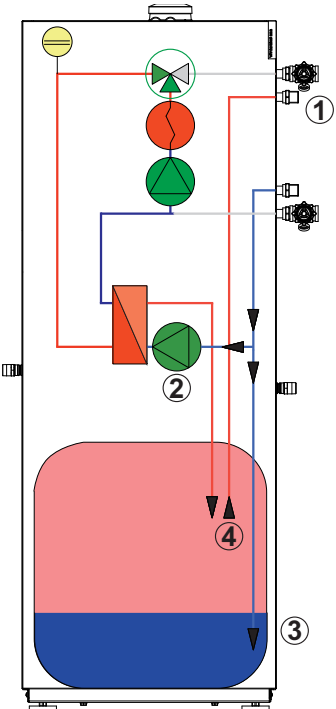

Large DHW Loads (>3.5 GPM)

When a 222-F is required to satisfy a large dump load, the STLS has the ability to extract stored energy from the onboard tank to meet the desired load. Consider a bath tub that requires a flow rate of 4.4 GPM(1). Since the DHW circulator(2) is preset to 3.4gpm, the additional 1 gpm of cold water will enter into the tank(3). As the 3.4g of hot water enters the tank, it immediately enters the DHW outlet(4). Since this 3.4g is not enough to satisfy the demand, 1gpm is taken from the tank to meet this target outlet flow rate. This allows for a ten minute draw rate of over 60USG.

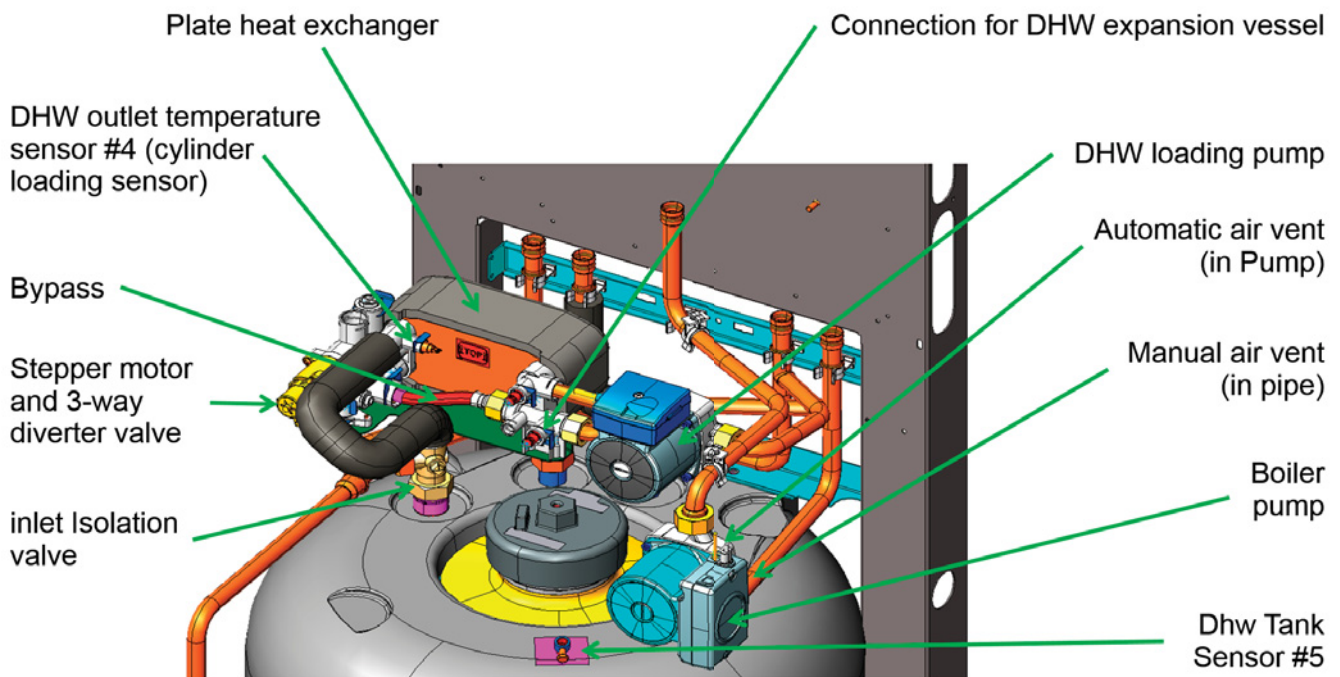

Vitodens 222-F, B2TB 68 and 125



Notes/Comments

Low Loss Header

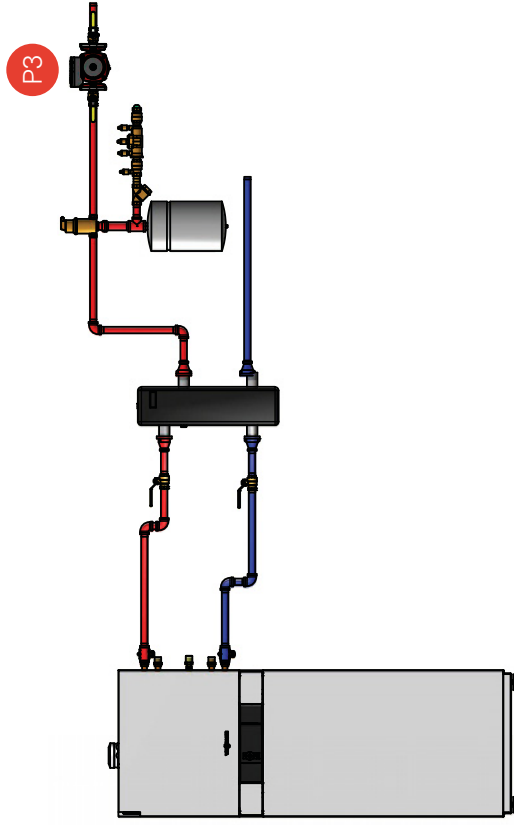

Closely Spaced Tee's

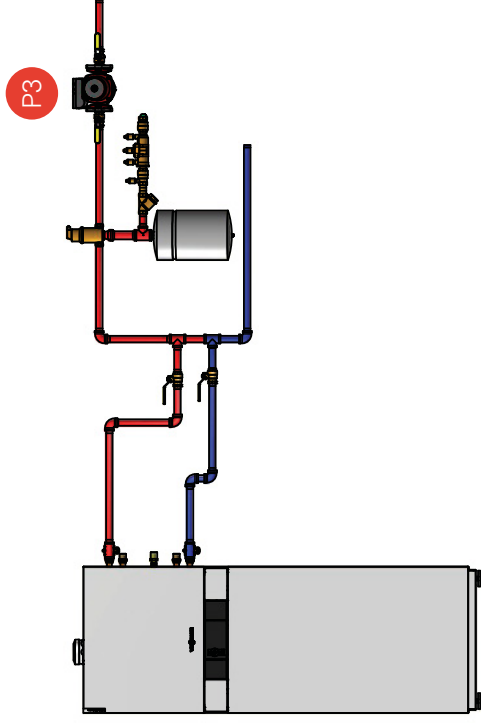

Notes / Comments

1. Hydraulically separating the flow of the boiler and system with closely spaced tees or a low loss header, ensures that the boiler and system flows do not affect each other.
2. The P1 boiler circulator is integrated into the boiler. For more information related to sizing and flow, please refer to page 13-15.
3. Refer to component index on Page 5.



Pressure Drop B2TB

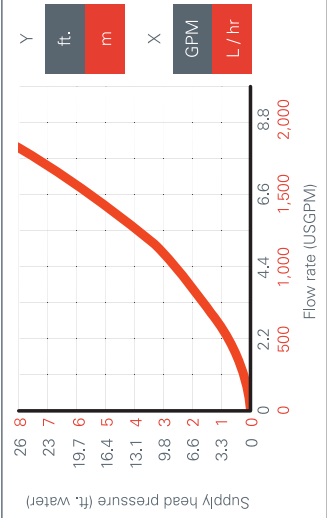

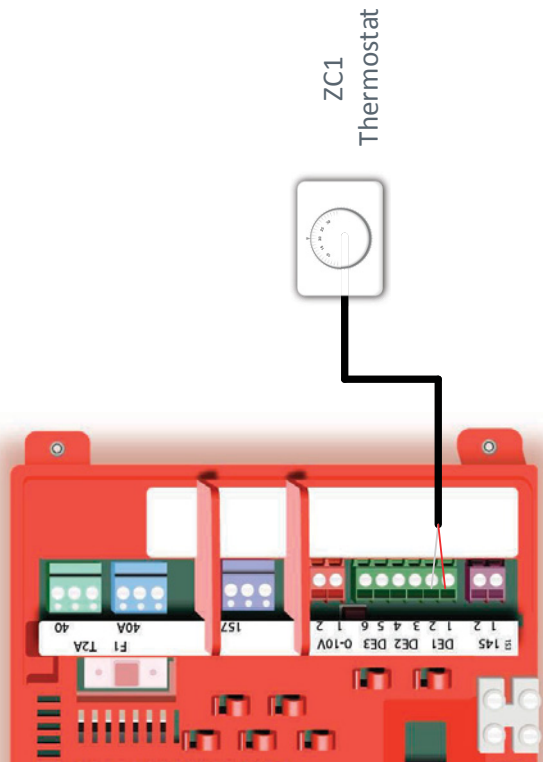
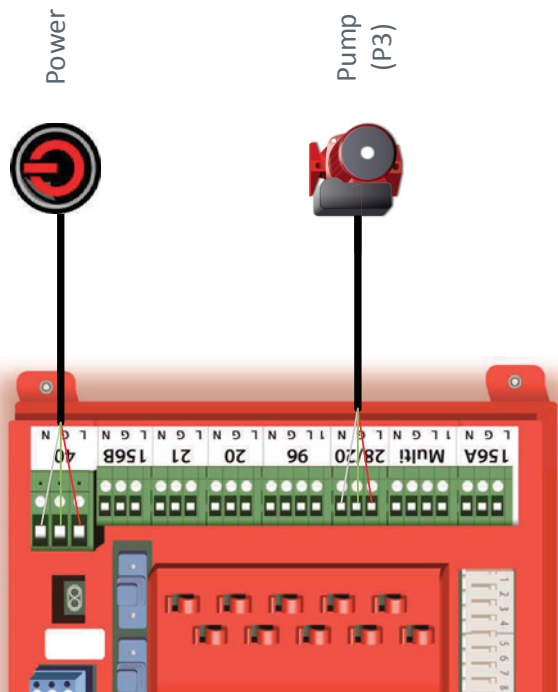

Application Code

VD2T1HC1T1ZP.01



 Application Code
VD2T 1HC1T1ZP.01

 Notes / Comments

1. For a simplified installation and more intelligent operation, the Vitotrol 200-A and Vitotrol 300-A can be used in place of a traditional thermostat.
2.  indicates optional connection.

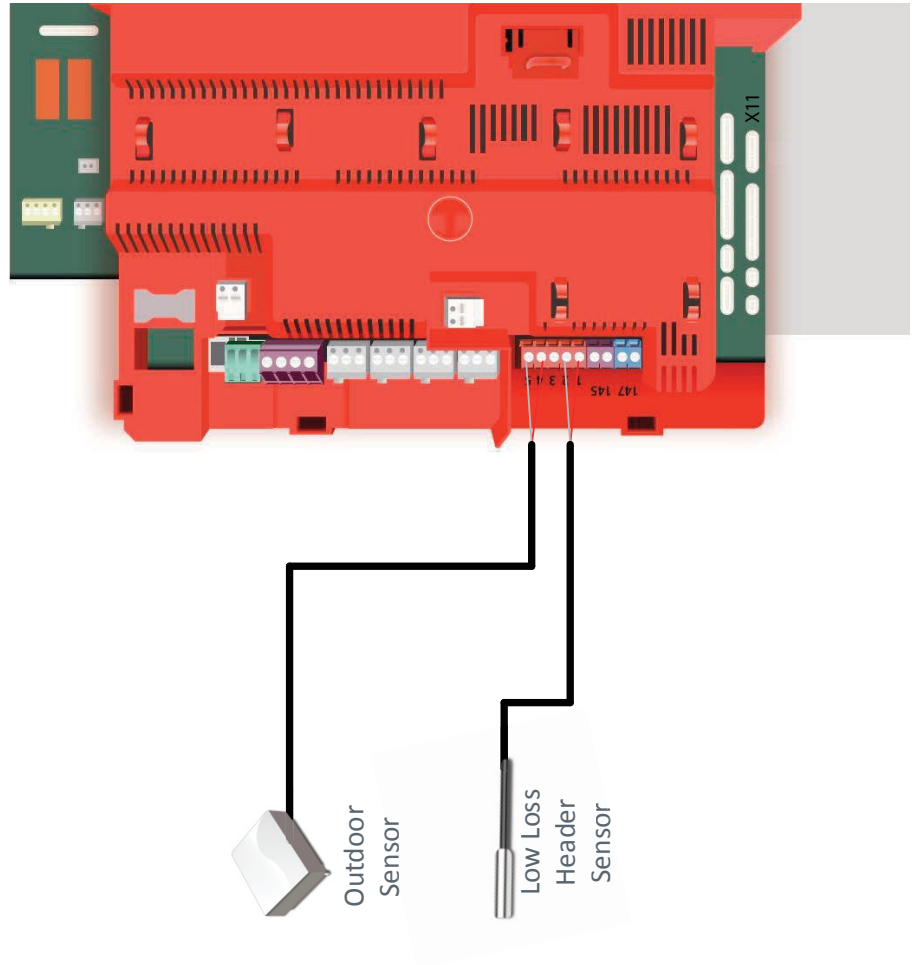

Zone Control Wizard Setup 1 Zone Circuit: Fixed Set Point OR Weather Compensated

This particular application represents a low mass boiler with a single system loop. Because the system flow requirements may vary or fall outside of the parameters of the boiler's recommended flow, it is beneficial to hydraulically separate the system flow from the boiler flow. This can be achieved by using a low loss header or closely spaced tees on the system loop. A low loss header sensor can be installed allowing better system control and increased efficiency. A ZC1 thermostat call will be sensed by the EA1 module and turn on the configured 28/20 P3 pump providing the necessary flow. Depending on the ZC1 configuration, it is possible to provide either a fixed setpoint or a weather compensated control option.

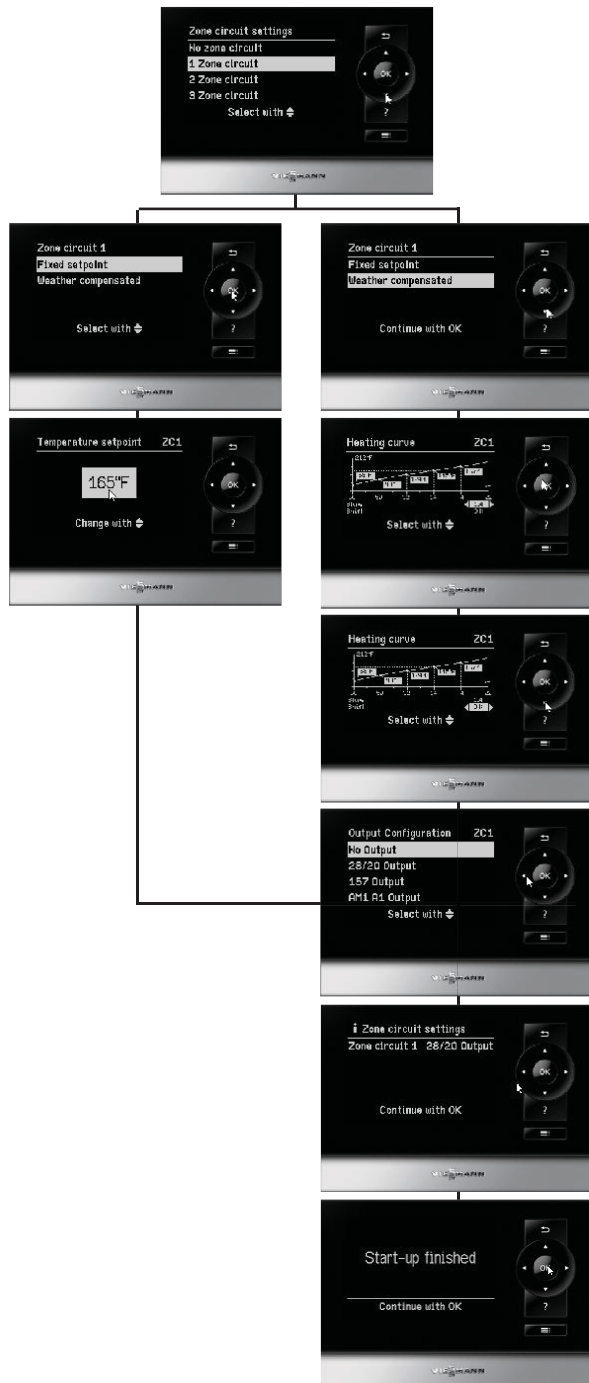

Select the correct number of Zone Circuit connections with respect to the number of thermostats connected to the DE connections. Press OK

Depending on how the zone temperature set point is determined, select either Fixed Setpoint or Weather Compensated. Adjustments to either setting will follow.

Fixed Setpoint: Enter the value that is to be used by the boiler as a target water temperature when there is a call for heat.

Weather Compensated: The Slope and Shift settings can be adjusted to allow a heating curve to be set. When there is a zone heat demand, the calculated set point will be used as long as the demand is present.

Select the desired pump output that will be enabled during a ZC call. When there is a call, the output will be energized for the duration of the call.

The zone circuit setting output summary shows the selected pumps depending on the number of zones selected in the very beginning.

The Start-up is finished and boiler is ready for operation.



Further Considerations

DHW Production

Set timer schedule as desired. If DHW production possible at any time, program timer settings to 0:00 to 24:00



Notes/Comments

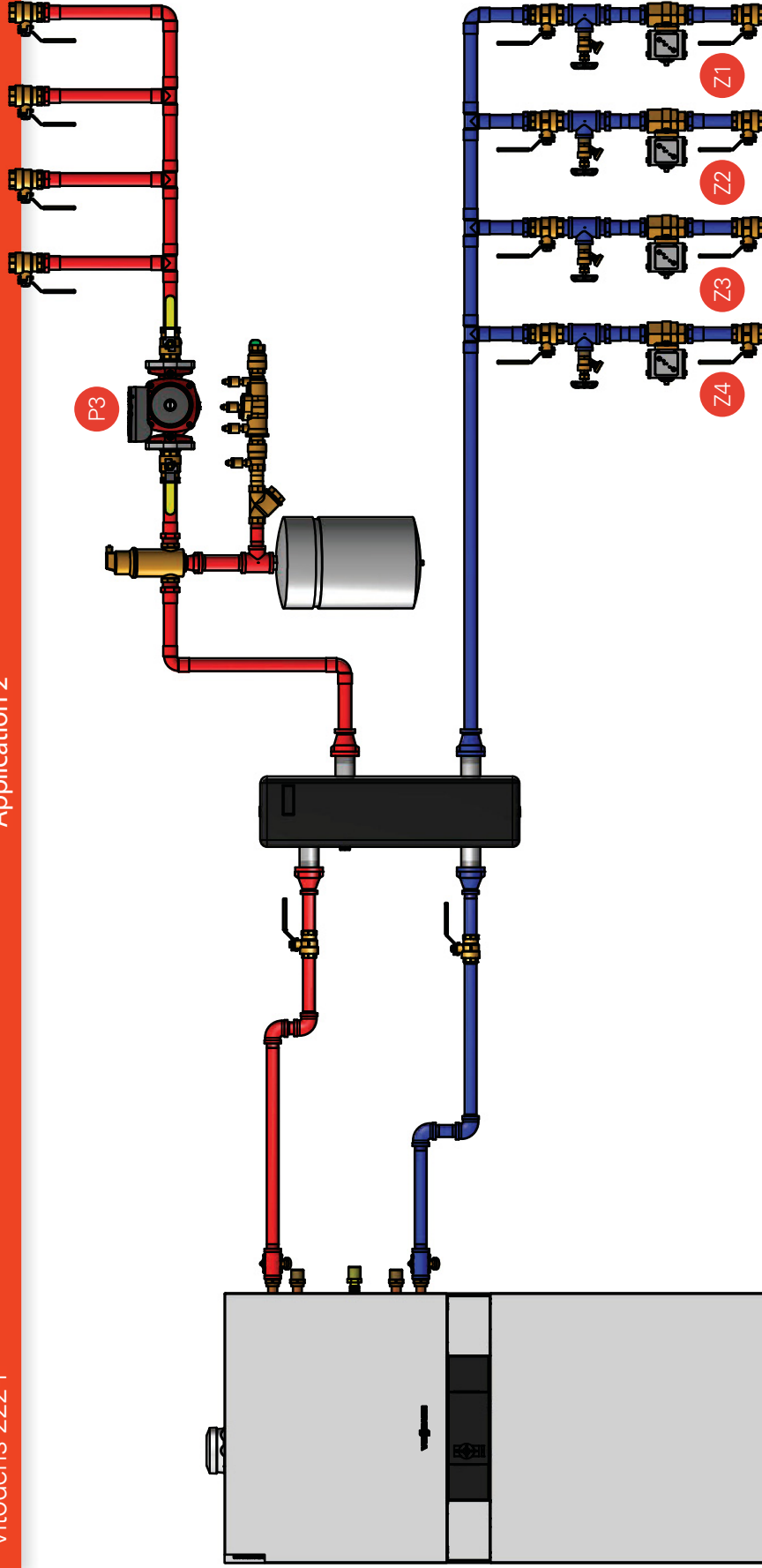

Notes / Comments

1. Hydraulically separating the flow of the boiler and system with closely spaced tees or a low loss header, ensures that the boiler and system flows do not affect each other.
2. The P1 boiler circulator is integrated into the boiler. For more information related to sizing and flow, please refer to page 13-15.
3. Refer to component index on Page 5.



Pressure Drop B2TB

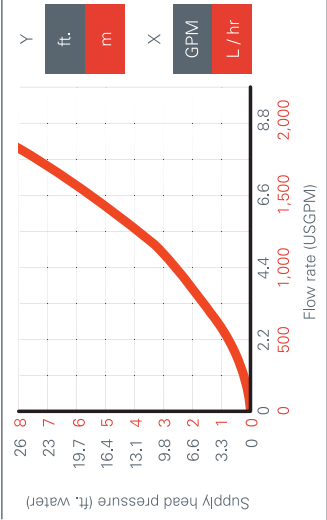

Application Code

VD2T 1HC1T4ZV.01

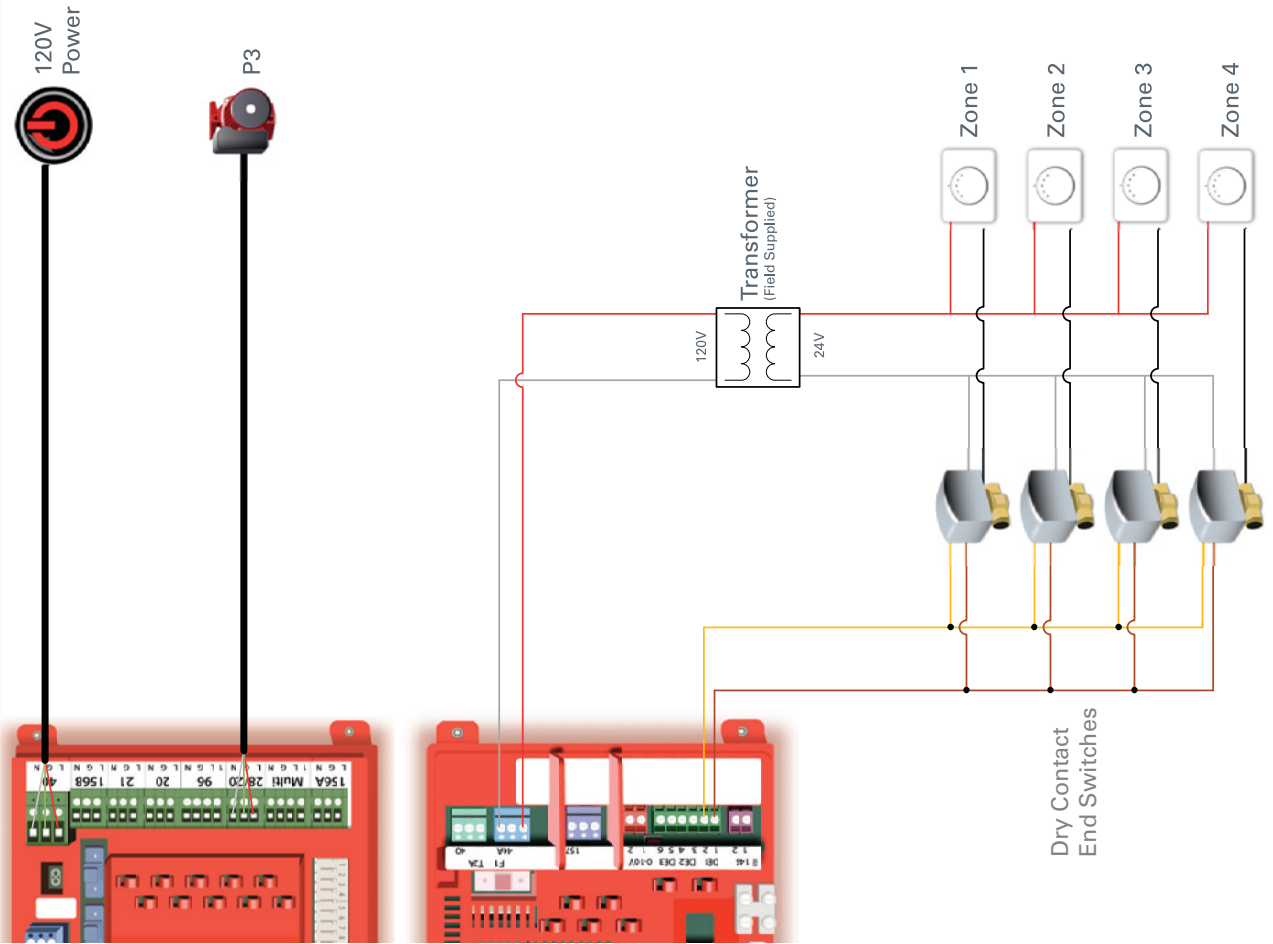

Application Code
 VD2T 1HC1T4ZV.01

- Notes / Comments**
1. Ensure the field supplied transformer is sized appropriately to accommodate the load of the zone valves.
 2. The transformer/zone valves will only have power when the boiler is powered. Therefore if the power supply to the boiler is turned off for service, all zone valves/thermostats will be inactive.
 3. This application can also be achieved through the use of a zone valve multi-zone control as shown in application #3.

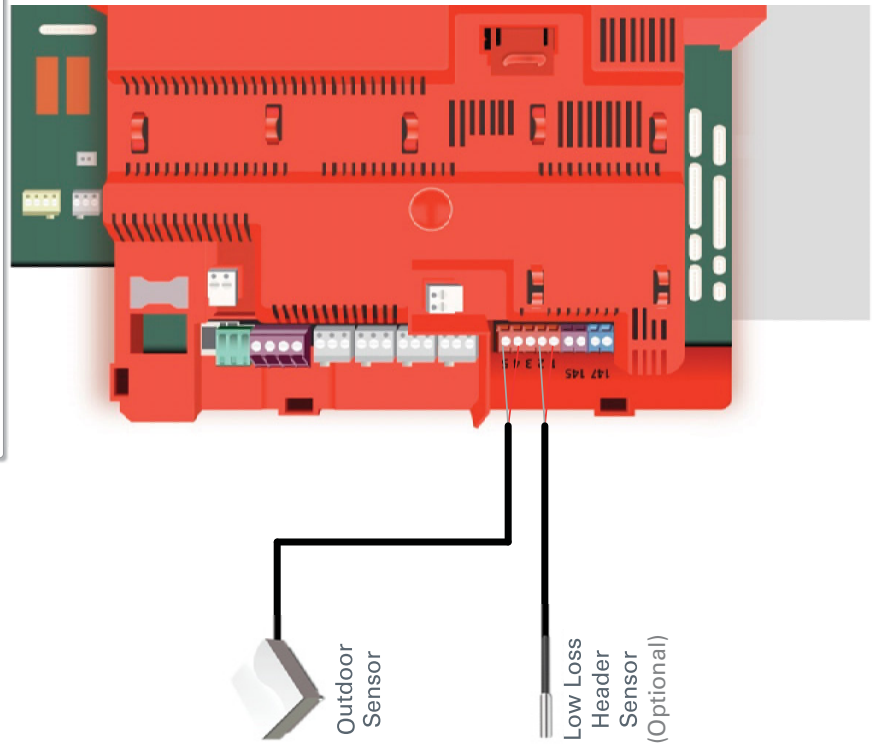

Zone Control Wizard Setup 1 Zone Circuit: Fixed Set Point with 157 Pump Output

In this system you have a Vitodens 200 with an indirect water heater and a four-zone single temperature system. Upon a call for heat from one of the four zone thermostats, the respective zone valve will open. The end switch will provide a demand input DE1 of the EA1 module. The 157 plug connected P3 pump will turn on and the boiler will use the ZC set point to provide a target boiler water temperature. In the event there is a call for DHW, the P1 circulator will turn off and P2 will be engaged. This will provide a domestic priority function for the purpose of quickly satisfying a DHW demand. It is recommended to use a variable speed circulator for P3 that will adjust flow based on opening/closing zone valves. If a single speed pump is being used, ensure a pressure differential bypass is incorporated into the system to avoid “over pumping” a single circuit when a zone is calling for heat.

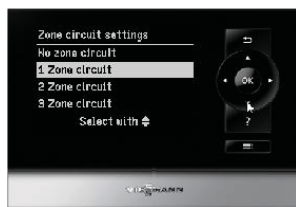

Since this particular zone application is a single temperature circuit, select 1 Zone Circuit from the menu options.



This application is based on a Fixed Setpoint temperature during a zone call for heat. Press OK to confirm selection.

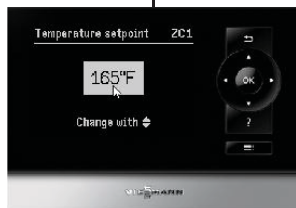

Enter the value that is to be used by the boiler as a target water temperature where there is a call for heat. You can adjust the values by arrowing down or up to the correct set point value and press OK.

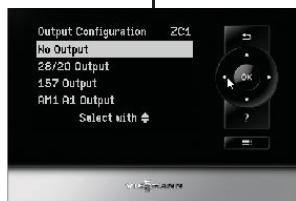

The pump based on this application is controlled by the 157 output. Arrow down until 157 Output is highlighted and press OK.



The zone circuit setting output summary shows the selected pumps depending on the number of zones selected in the very beginning. Press OK to continue.



The Start-up is finished and boiler is ready for operation. Press OK to continue



Further Considerations

DHW Production

Set timer schedule as desired. If DHW production possible at any time, program timer settings to 0:00 to 24:00



Notes/Comments

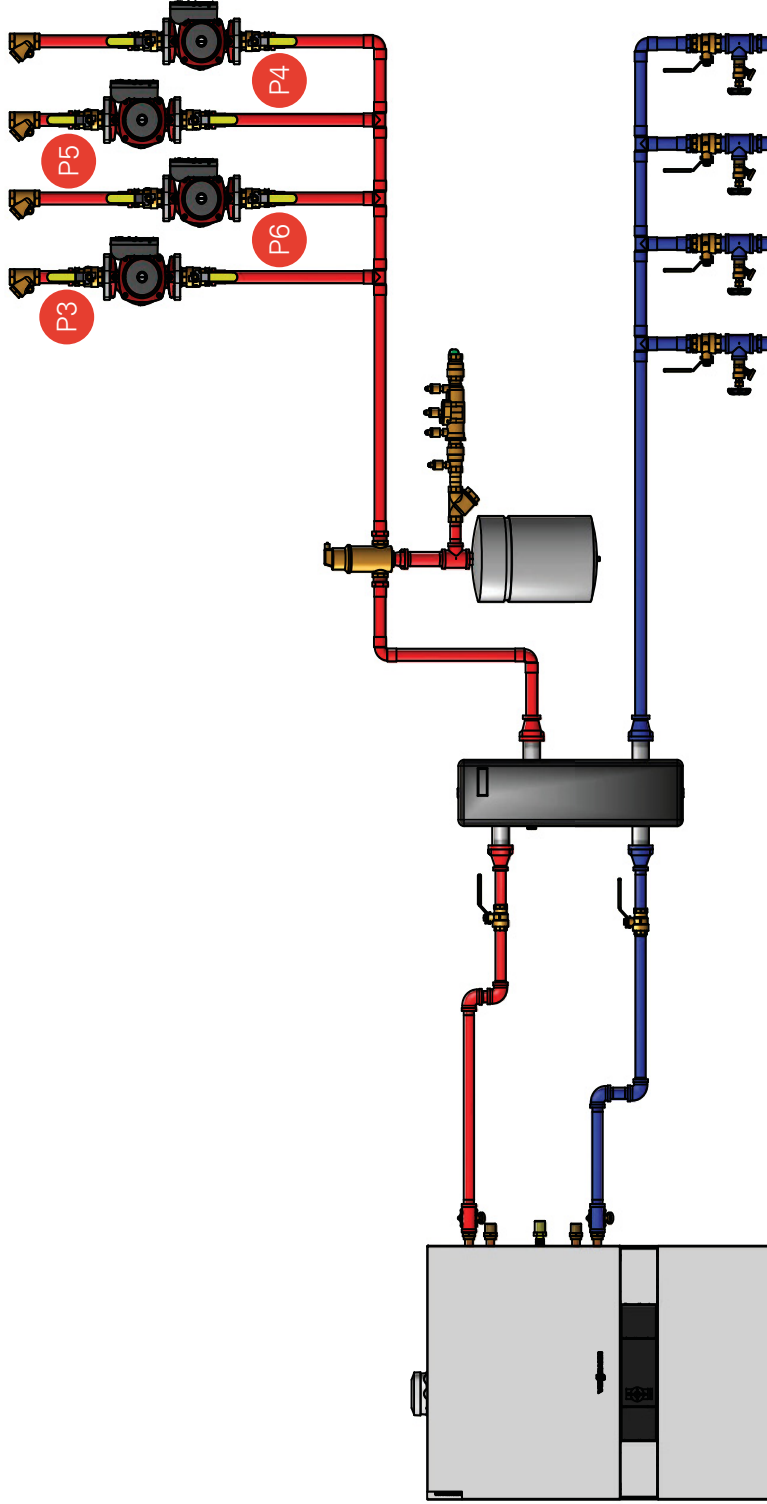

Notes / Comments

1. Hydraulically separating the flow of the boiler and system with closely spaced tees or a low loss header, ensures that the boiler and system flows do not affect each other.
2. The P1 boiler circulator is integrated into the boiler. For more information related to sizing and flow, please refer to page 13-15.
3. Refer to component index on Page 5.



Pressure Drop B2TB

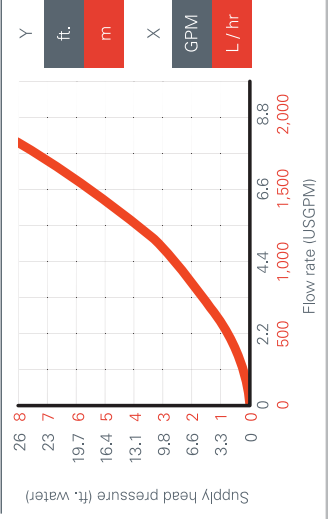

Application Code

VD2T 1HC1T4ZP.01



Application Code
 VD2T 1HC1T4ZP.01

Notes / Comments

1. Connection between the multizone control and the DE contact on the boiler is optional. See appropriate coding on the following page.
2. ●●●●● indicates optional connection.

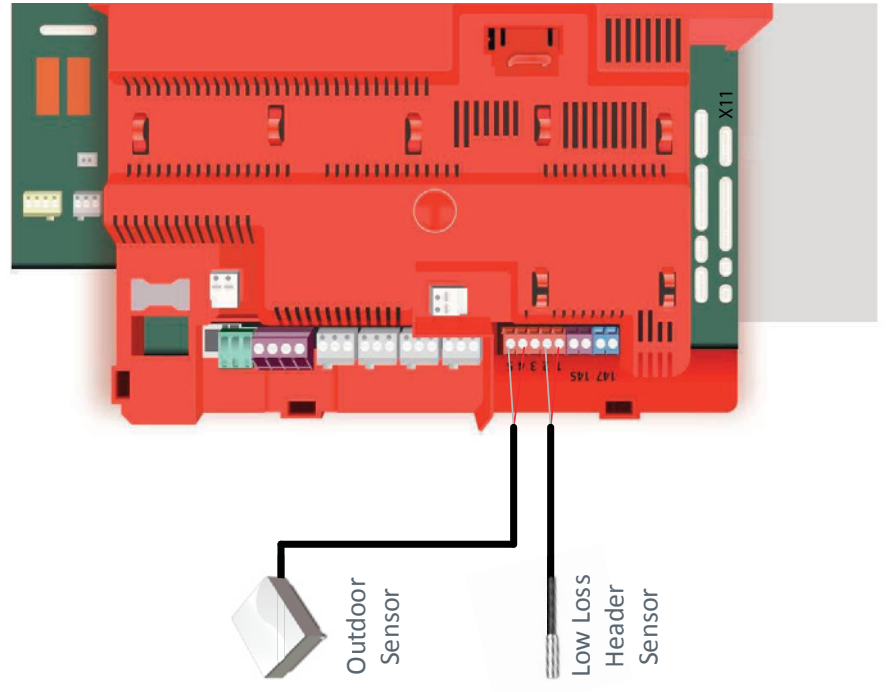
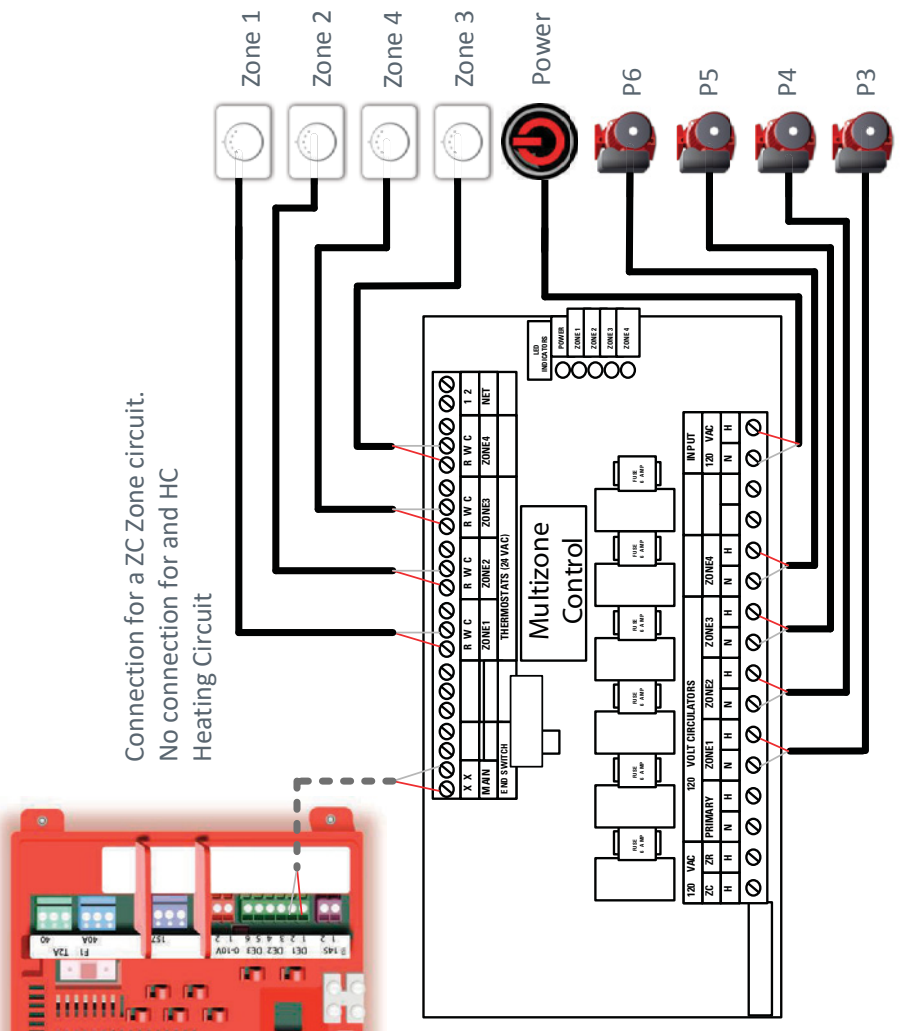

Application 3 Operational Setup Instructions

If you are zoning with pumps, consider this application for your next install. This system shows a Vitodens 200 with an indirect water heater and a four zone single temperature system. Upon a call for heat from a thermostat, the associated zone pump is energized by the multi-zone control. The connection of the heat demand output of the Multizone Control will provide a demand to the DE1 of the EA1 module generating a ZC1 set point demand. This is a very simple control solution for single temperature applications.

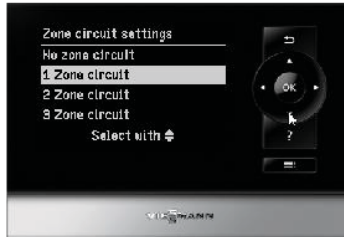

Since this particular application is a single temperature circuit, select 1 Zone Circuit from the menu options.

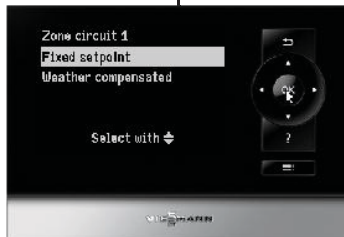

This application is based on a Fixed Setpoint temperature during a zone call for heat. Press OK to confirm selection.



Enter the value that is to be used by the boiler as a target water temperature where there is a call for heat. You can adjust the values by arrowing down or up to the correct set point value and press OK.

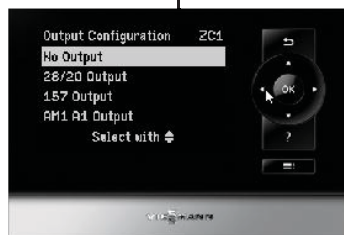

There is no assigned pump for this application. Pressing the OK button will not assign any specific pump output

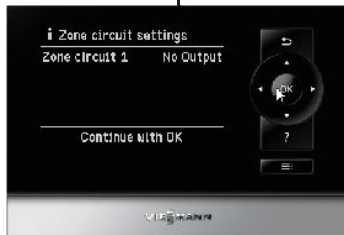

The zone circuit summary indicates no pumps selected.



The Start-up is finished and boiler is ready for operation. Press OK to continue



Further Considerations

DHW Production

Set timer schedule as desired. If DHW production possible at any time, program timer settings to 0:00 to 24:00



Notes/Comments

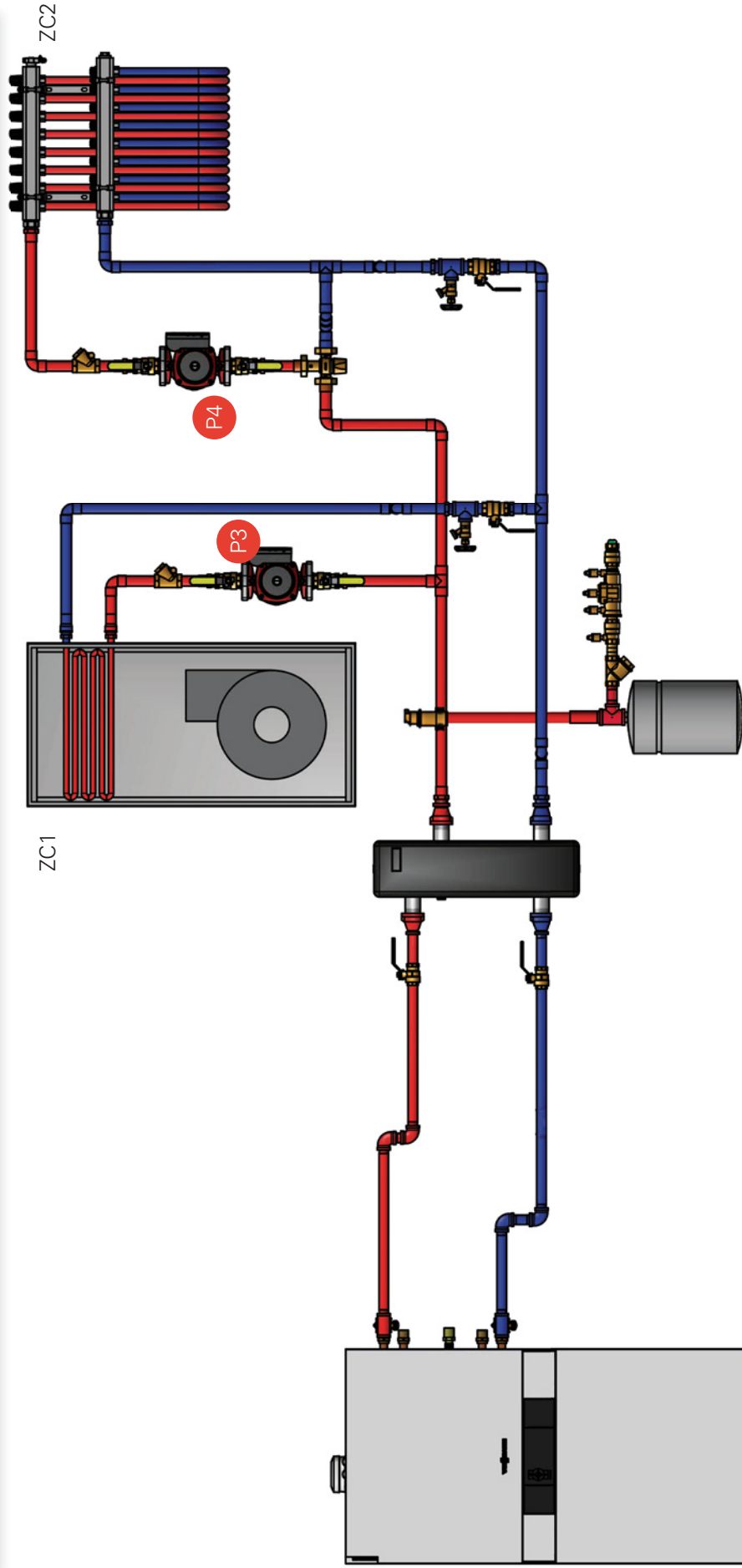

Pressure Drop B2TB

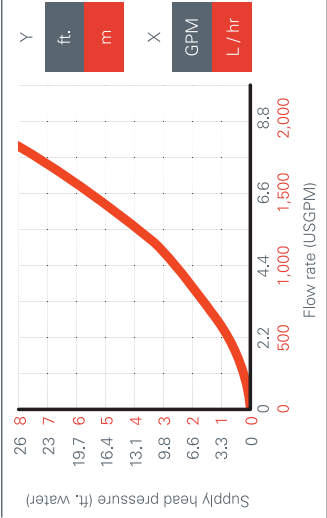

Notes / Comments

1. Hydraulically separating the flow of the boiler and system with closely spaced tees or a low loss header, ensures that the boiler and system flows do not affect each other.
2. The P1 boiler circulator is integrated into the boiler. For more information related to sizing and flow, please refer to page 13-15.
3. Refer to component index on Page 5.



Application Code

VD2T 2ZC2T2ZP.01

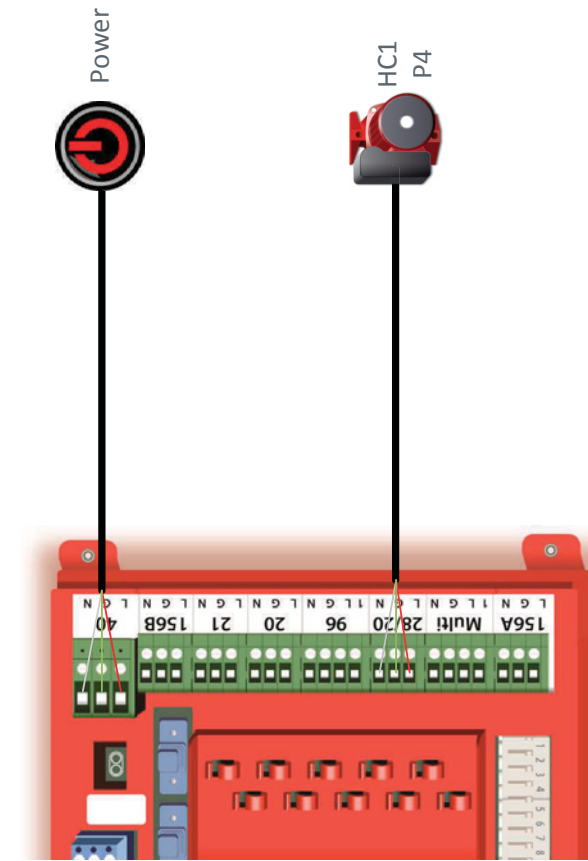

Application Code

VD2T 2HC2T2ZP.01

Notes / Comments

1. The (P3) circulator in Heat circuit 2 is controlled by the air handler.
2. Heat demand contact from air handler must be a dry contact / potential free.
3. The dry contact for the radiant heat circuit could come from a device such as a thermostat, zone valve, or multi-zone controller.

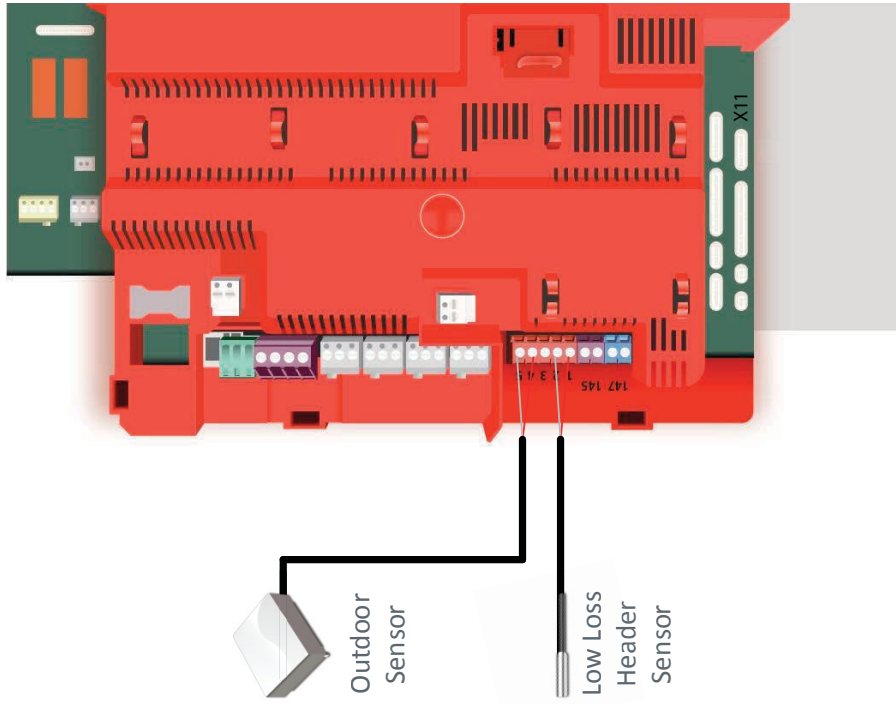
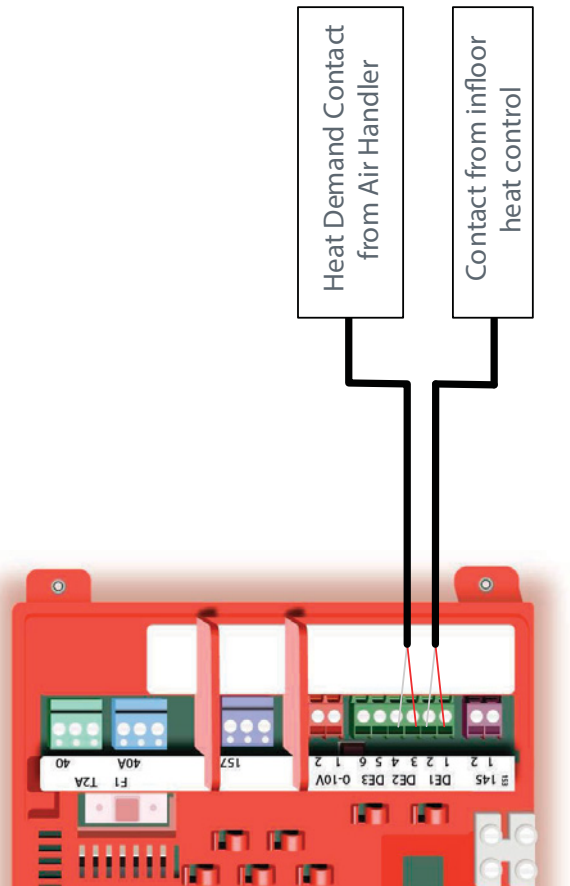

Zone Control Wizard—2 ZC—ZC1 Setpoint Demand with ZC2 Weather Compensated

This application features two heat circuits which operate at different temperatures. This particular drawing portrays ZC1 as a low temperature circuit and the air handler as a mid/high temperature circuit, ZC2. Although there are many different configurations, the setup below will operate ZC1 as an on/off function where an outdoor reset curve will be enabled during a thermostat call. The ZC2 air handler will operate on a constant temperature setpoint also referred to as a Fixed Setpoint. It is important to provide a method of protecting the ZC1 from high water temperatures when the air handler is operating, so don't forget to include the thermostatic mixing valve. The ZC1 shown here is configured with pump output 28/20 and the ZC2 call will bring on the 157 plug connected pump should there be a call for heat.

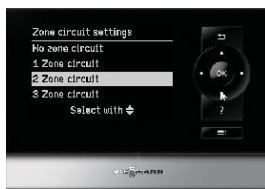

Select the correct number of Zone Circuit connections with respect to the number of thermostats connected to the DE connections. Press OK

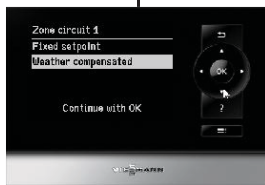

This application is based on a Weather Compensated, arrow down and press OK to confirm setting.

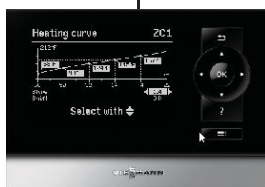

The Slope and Shift settings can be adjusted to allow a heating curve to be set. When there is a zone heat demand, the calculated set point will be used as long as the demand is present. Arrow up or down to move to the shift setting from slope. Making an adjustment of either setting will graphically indicate how the heating curve moves.

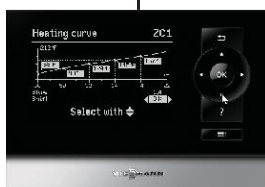

Once the settings have been made, press OK to continue. These settings can be easily adjusted later on should they need to be changed.

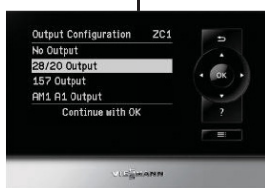

The ZC1 pump for this particular application is the 28/20 pump. Pressing OK continues to the ZC2 circuit,



The Zone Circuit 2 is to be set for Fixed Setpoint temperature demand. Press OK to select and continue. The next screen allows for a set point adjustment of the zone target temperature



The final step in this application configuration is to select the associated pump for ZC2. Select the 157 Output and press OK.

Following will be the output summary and the start up configuration is finished



Further Considerations

DHW Production

Set timer schedule as desired. If DHW production possible at any time, program timer settings to 0:00 to 24:00



Notes/Comments

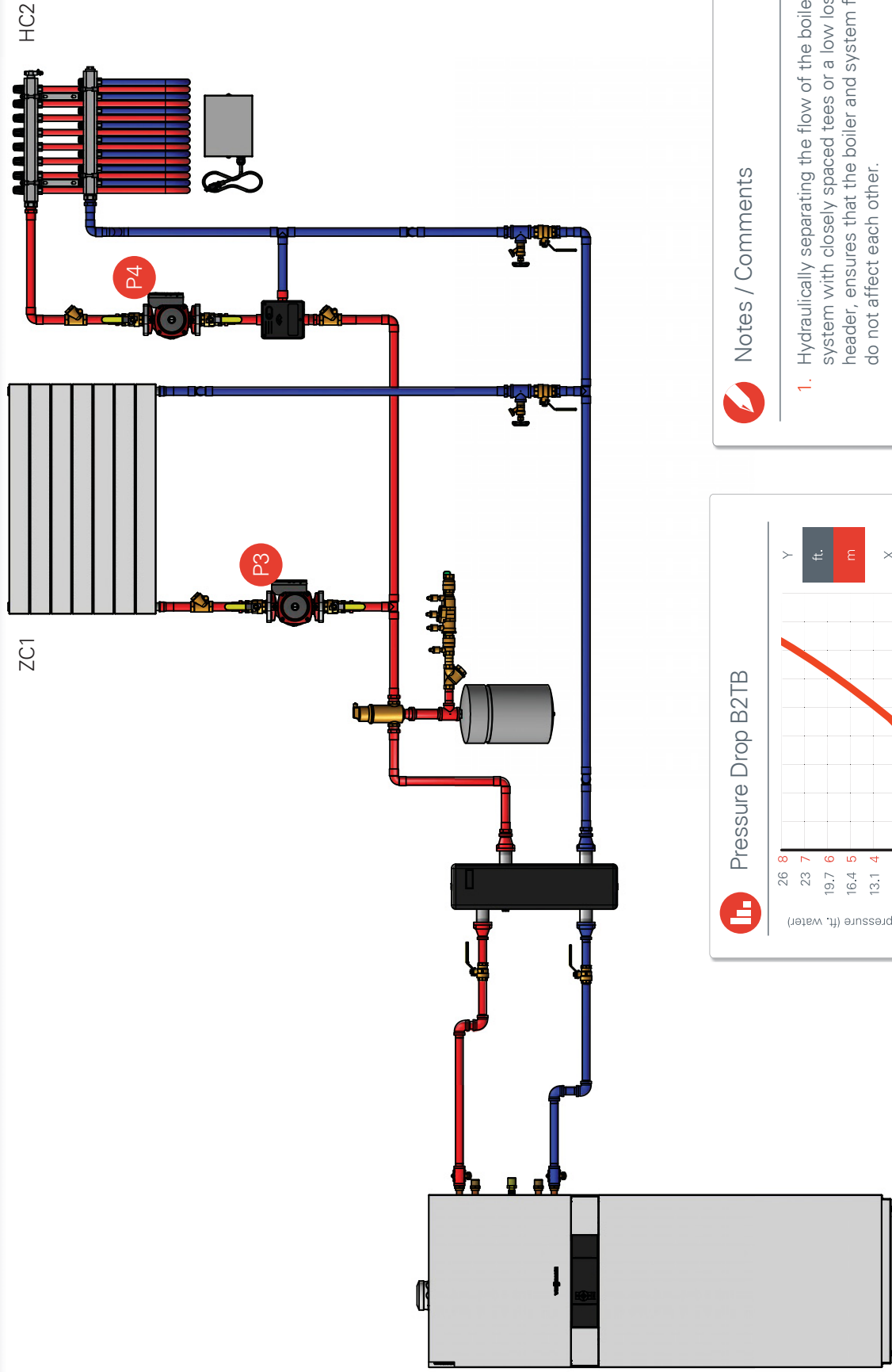

 Application Code
VD2T 2ZC/HC2T2ZP.02

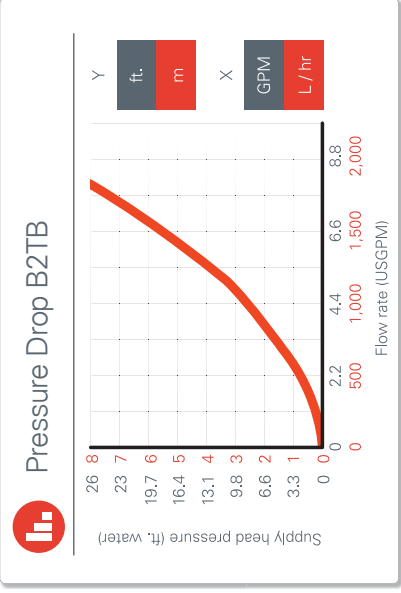

-  Notes / Comments
1. Hydraulically separating the flow of the boiler and system with closely spaced tees or a low loss header, ensures that the boiler and system flows do not affect each other.
 2. The P1 boiler circulator is integrated into the boiler. For more information related to sizing and flow, please refer to page 13-15.
 3. Refer to component index on Page 5.

 Application Code
VD2T 2HC2T2ZP.02

 Notes / Comments

1. For more information regarding the wiring of the Mixing Valve Module, see page 17.
2. The thermostats on this application can be substituted for Vitotrols. This simplifies setup and offers the user additional control of the space.
3. Don't forget about the jumper between the 40A plug and the 157 Plug.*

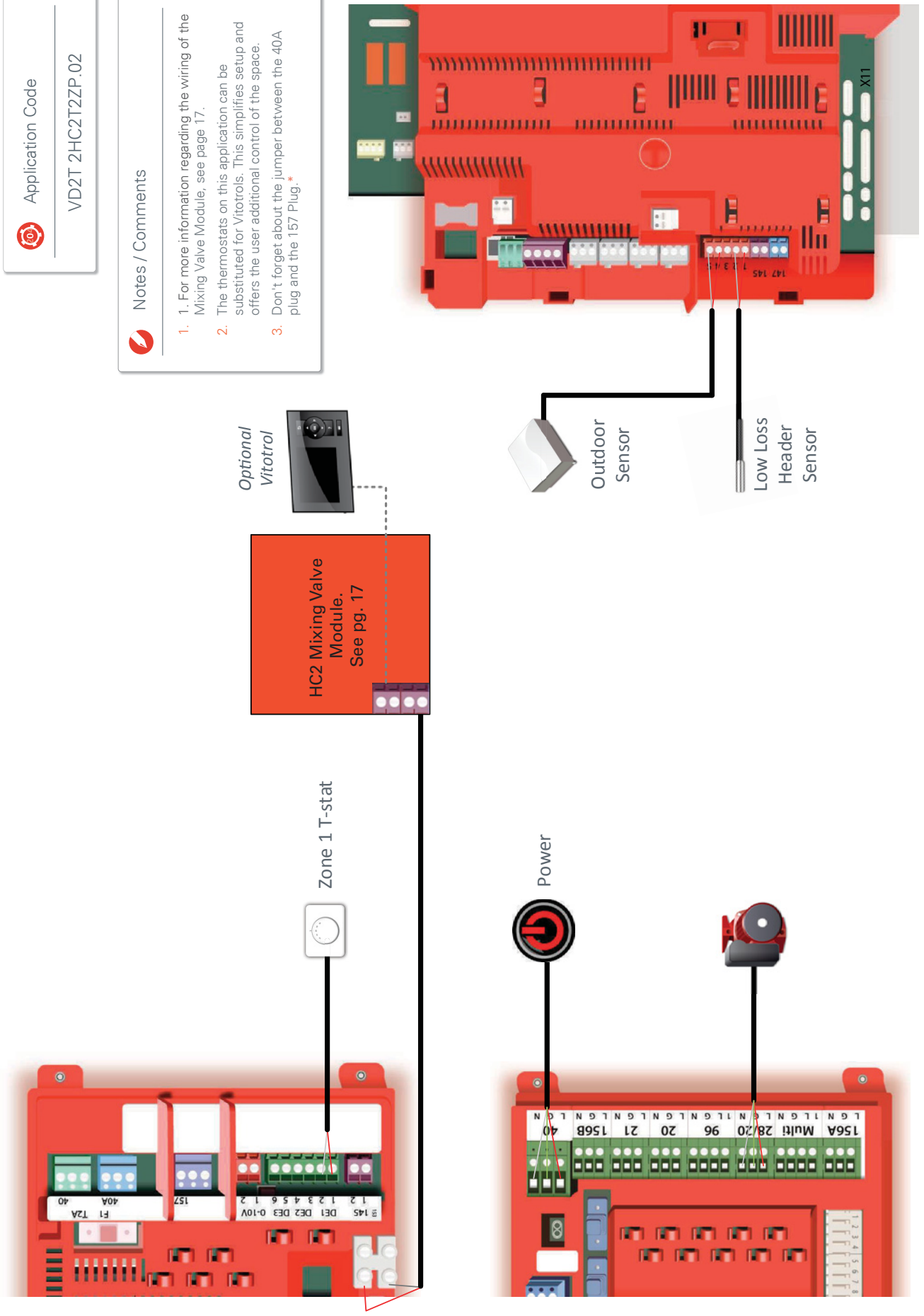

Application 5 Operational Setup Instructions

This application shows a low temperature heat circuit with 3-way mixing valve, a high temperature heating circuit ZC1. This application allows for simultaneous operation of both space heating and DHW, just remember to size your boiler accordingly. A ZC1 call will turn on the configured 28/20 plug connected pump providing flow for the high temperature zone. The HC2 mixing valve will operate from heating curve settings, set within the boiler control.

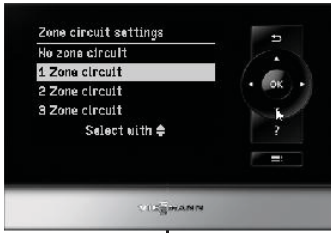

Select the correct number of Zone Circuit connections with respect to the number of thermostats connected to the DE connections. Press OK

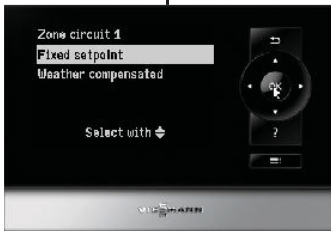

This application is based on a Fixed Setpoint temperature during a zone call for heat. Press OK to confirm selection.



Enter the value that is to be used by the boiler as a target water temperature where there is a call for heat. You can adjust the values by arrowing down or up to the correct set point value and press OK.

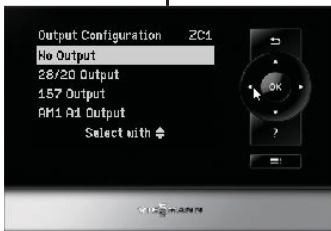

The pump based on this application is controlled by the 28/20 output. Arrow down until 157 Output is highlighted and press OK.



The zone circuit setting output summary shows the selected pumps depending on the number of zones selected in the very beginning. Press OK to continue.



The Start-up is finished and boiler is ready for operation. Press OK to continue



Further Considerations

DHW Production

Set timer schedule as desired. If DHW production possible at any time, program timer settings to 0:00 to 24:00



Notes/Comments

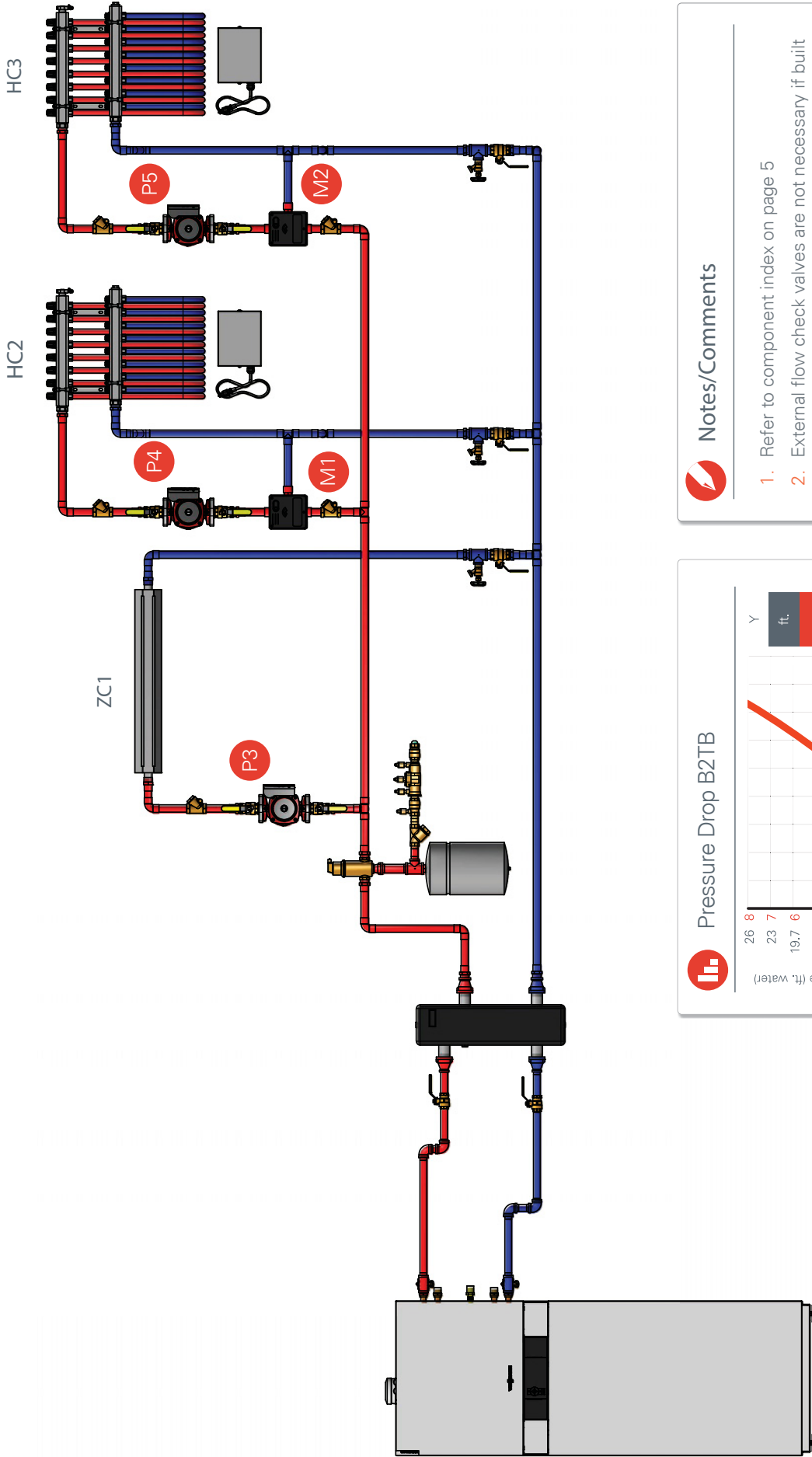

Application Code

VD2T 3HC3T3ZP.01



Pressure Drop B2TB

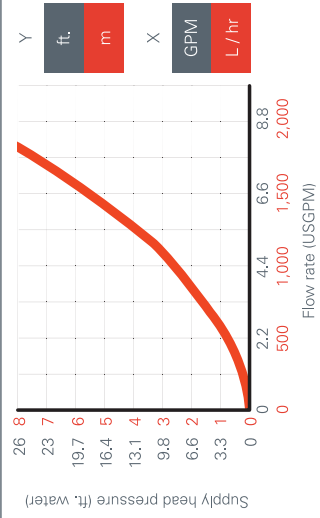

Notes/Comments

1. Refer to component index on page 5
2. External flow check valves are not necessary if built into the circulators.
3. The P1 boiler circulator is integrated into the boiler. For more information related to sizing and flow, please refer to page 13-15.

 Application Code
VD2T 3HC3T3ZP.01

 Notes / Comments

1. To minimize system setup, the thermostats can be substituted with Vitotrol room controls. This provides a communicating room control that will increase the comfort of the space.
2. A single control must be selected for each heat circuit. (i.e. Thermostat or Vitotrol)

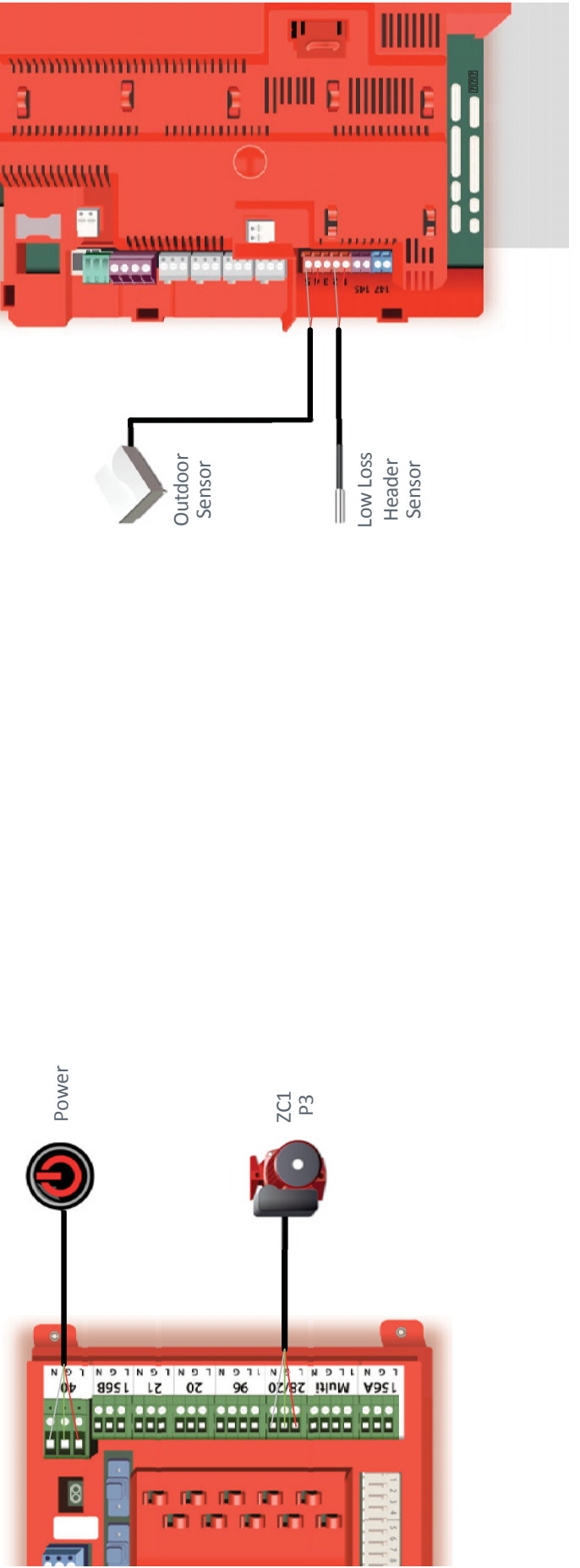
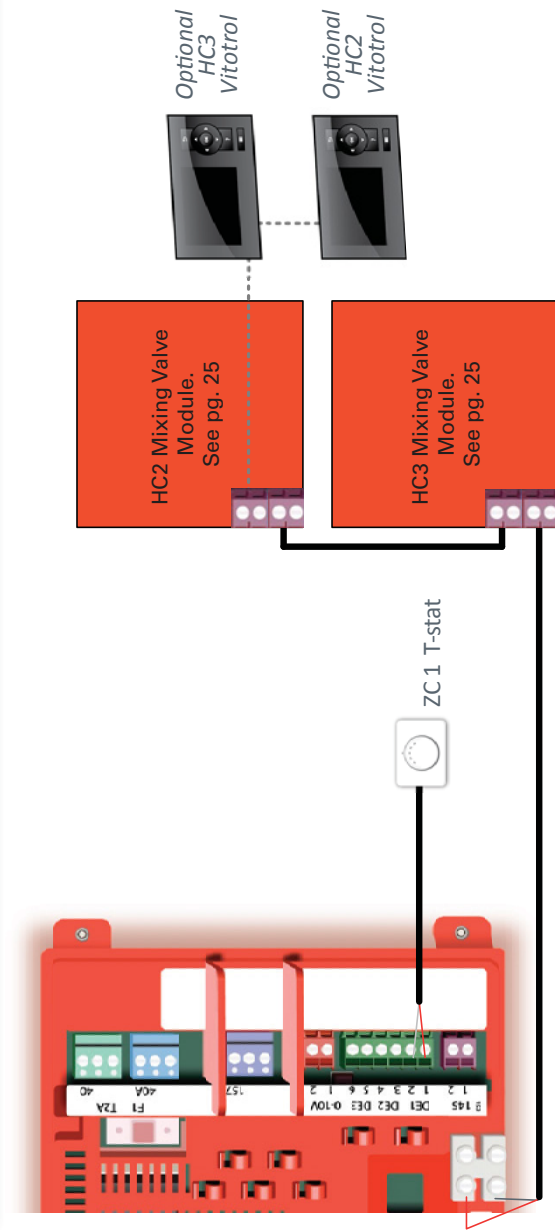

Zone Control Wizard Setup 1 Zone Circuit: Fixed Set Point with 157 Pump Output

This application shows 2 heat circuits with mixing valves, a high temperature heat circuit. This system approach maximizes system efficiency, control and comfort through precise water monitoring. The ZC1 thermostat call for heat will enable 28/20 plug to power the P3 pump providing flow in the unmixed temperature heating circuit. The ZC1 circuit can be configured to operate based on a Fixed Setpoint demand temperature or a Weather Compensated demand. The HC2 and HC3 mixing valve controls will operate based on heat curve settings from within the boiler.

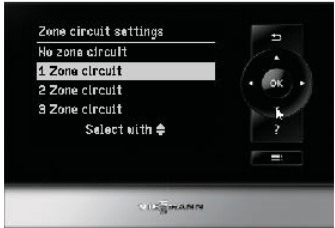

Select the 1 Zone Circuit with respect to the ZC thermostat connected to the DE connections. Press OK



This application is based on a Fixed Setpoint temperature during a zone call for heat. Press OK to confirm selection.



Enter the value that is to be used by the boiler as a target water temperature where there is a call for heat. You can adjust the values by arrowing down or up to the correct set point value and press OK.

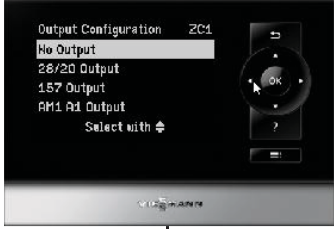

The pump based on this application is controlled by the 157 output. Arrow down until 157 Output is highlighted and press OK.



The zone circuit setting output summary shows the selected pumps depending on the number of zones selected in the very beginning. Press OK to continue.



The Start-up is finished and boiler is ready for operation. Press OK to continue

Further Considerations

DHW Production

Set timer schedule as desired. If DHW production possible at any time, program timer settings to 0:00 to 24:00

Notes/Comments

This is Viessmann

The Viessmann Group is one of the world's leading manufacturers of heating and renewable energy systems. Family-owned since 1917, Prof. Dr. Martin Viessmann leads the company in its third generation. The group today employs over 11,400 employees worldwide and has a turnover of approx. 2.1 billion Euro. 27 manufacturing facilities in 11 countries, sales & distribution facilities in Germany and 74 other countries, and 120 sales offices worldwide provide customer proximity and a strong global presence. For three generations, Viessmann has been providing comfortable, efficient and environmentally-responsible heating solutions, tailored to the needs of the market. With ongoing research and development and a focus on product innovation, Viessmann has pioneered technologies that have continuously set standards and made the company into a technological innovator and pace-setter of the entire industry.

With the current comprehensive product range, Viessmann is offering a multi-level program of high-tech, state-of-the-art heating products. Wall-mounted gas-fired condensing boilers, floor-standing oil – or gas-fired hot water heating boilers, solar thermal systems, control technology

and DHW storage tanks – all designed to achieve superior performance, reliability and energy savings.

Accountability for the environment and society, fairness when dealing with business partners as well as the pursuit of perfection and maximum efficiency in all business transactions are key values for Viessmann – as a company, and as individuals. This, together with the products and services we offer, allows us to offer our customers the benefit and added value of a strong brand.

Viessmann Manufacturing Company Inc.
750 McMurray Rd.
Waterloo, ON N2V 2G5, Canada
1-800-387-7373
info@viessmann.ca
www.viessmann.ca

Viessmann Manufacturing Company Inc.
6350 204th St.
Langley, BC V2Y 2V1, Canada
1-877-853-3288
info-bc@viessmann.ca
www.viessmann.ca

Viessmann Manufacturing Company Inc. USA
45 Access Rd.
Warwick, RI 02886, USA
1-800-288-0667
info@viessmann-us.com
www.viessmann.com

Global presence, local commitment.



Langley
British Columbia



Waterloo
Ontario



Warwick
Rhode Island



Viessmann Manufacturing
Company Inc.
Waterloo, ON Canada
1-800-387-7373
www.viessmann.ca